

Ordinary Council Meeting 27 October 2021

Shire of Lake Grace

Ordinary Council Meeting

Minutes

27 October 2021

Meeting Commencing at 2:30 pm



Disclaimer

No responsibility whatsoever is implied or accepted by the Shire of Lake Grace for any act, omission or statement or intimation occurring during Council or Committee meetings or during formal or informal conversations with staff. The Shire of Lake Grace disclaims any liability for any loss whatsoever caused arising out of reliance by any person or legal entity on any such act, omission or statement or intimation occurring during Council or Committee meetings or discussions. Any person or legal entity who acts or fails to act in reliance upon any statement does so at that person's and or legal entity's own risk.

In particular and without derogating in any way from the broad disclaimer above, in any discussion regarding any planning application or application for license, any statement or limitation or approval made by a member or officer of the Shire of Lake Grace during the course of any meeting is not intended to be and is not taken as notice of approval from the Shire of Lake Grace. The Shire of Lake Grace warns that anyone who has an application lodged with the Shire of Lake Grace must obtain and only should rely on WRITTEN CONFIRMATION of the outcome of the application and any conditions attaching to the decision made by the Shire of Lake Grace in respect of the application.

CONTENTS

1.0	DECLARATION OF OPENING ANNOUNCEMENT OF VISITORS	5
2.0	CONSTITUTIONAL MATTERS	5
2.1	ELECTION OF PRESIDENT.....	6
2.2	ELECTION OF DEPUTY SHIRE PRESIDENT.....	7
2.3	SEATING OF COUNCILLORS	8
2.4	DISCLAIMER READING AND ACKNOWLEDGMENT OF COUNTRY	9
3.0	RECORD OF ATTENDANCE/APOLOGIES/LEAVE OF ABSENCE (PREVIOUSLY APPROVED).....	11
3.1	PRESENT	11
3.2	APOLOGIES	11
3.3	LEAVE OF ABSENCE PREVIOUSLY GRANTED	11
4.0	RESPONSE TO PREVIOUS PUBLIC QUESTIONS TAKEN ON NOTICE	11
5.0	PUBLIC QUESTION TIME.....	11
6.0	PETITIONS/DEPUTATIONS/PRESENTATIONS.....	11
7.0	NOTATIONS OF INTEREST	11
7.1	DECLARATIONS OF FINANCIAL INTEREST – LOCAL GOVERNMENT ACT 1995 SECTION 5.60A	11
7.2	DECLARATIONS OF FINANCIAL PROXIMITY INTEREST – LOCAL GOVERNMENT ACT 1995 SECTION 5.60B.....	12
7.3	DECLARATIONS OF IMPARTIALITY INTEREST – ADMINISTRATION REGULATIONS 1996 SECTION 34C.....	12
8.0	APPLICATIONS FOR LEAVE OF ABSENCE.....	12
9.0	ANNOUNCEMENTS BY THE PRESIDING MEMBER WITHOUT DISCUSSION	12
10.0	CONFIRMATION OF MINUTES	12
10.1	ORDINARY COUNCIL MEETING - 29 SEPTEMBER 2021.....	12
10.2	SPECIAL COUNCIL MEETING.....	12
10.3	ANNUAL MEETING OF ELECTORS	12

11.0	MOTIONS OF WHICH PREVIOUS NOTICE HAS BEEN GIVEN.....	12
12.0	URGENT BUSINESS APPROVED BY THE PRESIDING MEMBER OR BY DECISION OF COUNCIL	12
13.0	REPORTS OF COMMITTEES	13
14.0	REPORTS OF OFFICERS.....	13
14.1	INFRASTRUCTURE SERVICES	13
14.1.1	UNBUDGETED EXPENDITURE FOR LAKE GRACE BASKETBALL BACKBOARDS AND RINGS	13
14.1.2	NEWDEGATE COUNTRY CLUB ALTERATIONS AND ADDITIONS	16
14.1.3	TRANSFER OF FUNDS – RURAL DRAINAGE WORKS.....	18
14.1.4	UNBUDGETED EXPENDITURE – AIR COMPRESSOR FOR MEDICAL CENTRE	21
14.2	PLANNING	23
14.3	HEALTH AND BUILDING	23
14.4	ADMINISTRATION.....	24
14.4.1	COUNCIL MEMBERSHIPS – SHIRE OF LAKE GRACE COMMITTEES OF COUNCIL	24
14.4.2	CHRISTMAS AND NEW YEAR 2021/2022 TRADING HOURS	31
14.4.3	SCHEDULE OF COUNCIL MEETINGS – FEBRUARY TO DECEMBER 2022 ...	34
14.4.4	NEWDEGATE 100 YEAR CENTENARY – RESERVE ACCOUNT	36
14.4.5	RELATED PARTY DISCLOSURE POLICY	39
14.4.6	APPOINTMENT OF AUTHORISED PERSONS – SHIRE OF LAKE GRACE	43
14.5	FINANCE.....	48
14.5.1	ACCOUNTS FOR PAYMENT – SEPTEMBER 2021	48
14.5.2	FINANCIAL REPORTS – 30 SEPTEMBER 2021.....	50
14.6	COMMUNITY SERVICES.....	52
15.0	QUESTIONS OF WHICH DUE NOTICE HAS BEEN GIVEN	52
16.0	INFORMATION BULLETIN – OCTOBER 2021.....	52
17.0	CONFIDENTIAL ITEMS AS PER LOCAL GOVERNMENT ACT S5.23 (2)	54

18.0 DATE OF NEXT MEETING – 24 NOVEMBER 2021..... 55

19.0 CLOSURE 55

20.0 CERTIFICATION 55

SHIRE OF LAKE GRACE

Minutes of the Ordinary Council Meeting held at Council Chambers, 1 Bishop Street, Lake Grace, WA on Wednesday 27 October 2021.

1.0 DECLARATION OF OPENING ANNOUNCEMENT OF VISITORS

The Chief Executive Officer opened the meeting at 2:30 pm and advised that today's Ordinary Council Meeting will consider the matters presented:

- Swearing-in of new Councillors
- Election of President
- Election of Deputy President
- Ballot for seating and
- Nomination of Council Committees

2.0 CONSTITUTIONAL MATTERS

The Chief Executive Officer will swear in the Councillors elect who were declared elected unopposed by the Returning Officer conducted as a postal vote on Saturday 16 October 2021.

In accordance with the Local Government Act 1995, [r13(1) (c)] a person elected as a Councillor has to make a declaration before acting in the office.

Regulation 13 of the Local Government (Constitution) Regulations 1998 prescribes that Form 7 is to be made available before a person is authorised to take statutory declarations under Oaths, Affidavits and Statutory Declarations Act 2005.

The declaration is as follows:

*I _____ of _____, having been elected to the office of **Councillor** of the Shire of Lake Grace, declare that I take the office upon myself and will duly, faithfully, honestly, and with integrity, fulfil the duties of the office for the people in the district according to the best of my judgement and ability, and will observe the Local Government (Rules of Conduct) Regulations 2007.*

Cr Ross Chappell, Cr Shane Carruthers, Cr Ben Hyde, Cr Steve Hunt, Cr Anton Kuchling and Cr Jeff McKenzie made and signed the declarations as required under the Local Government (Constitution) Regulations 1998 of the Local Government Act 1995.

In Schedule 2.3 of the *Local Government Act 1995* provides:

2. When Council Elects Mayor or President

- (1) *The office is to be filled as the first matter dealt with –*
 - (a) *at the first meeting of the council after an inaugural election or a section 4.13 or 4.1.4 election or after an ordinary elections day; and*
 - (b) *at the first meeting of the council after and extraordinary vacancy occurs in the office.*
- (2) *If the first ordinary meeting of the Council is more than 3 weeks after an extraordinary vacancy occurs in the office, a special meeting of the council is to be held within that period for the purpose of filling the office.*

3. CEO to Preside

The CEO is to preside at the meeting until the office is filled.

4. How Mayor or President is Elected

- (1) *The Council is to elect a councillor to fill the office.*
- (2) *The election is to be conducted by the CEO in accordance with the procedure prescribed.*
- (3) *Nominations for the Office are to be given to the CEO in writing before the meeting or during the meeting before the close of nominations.*
- (3a) *Nominations close at the meeting at a time announced by the CEO that nominations are about to close to allow for any nominations made to be dealt with.*
- (4) *If a Councillor is nominated by another Councillor the CEO is not to accept the nomination unless the nominee has advised the CEO, orally or in writing, that he or she is willing to be nominated for the office.*
- (5) *The Councillors are to vote on the matter by secret ballot as if they were electors voting at an election.*

2.1 ELECTION OF PRESIDENT

The Chief Executive Officer is to call for nominations for the office of Shire President.

The Shire President is to be elected by the Council from amongst the Councillors.

Nominations for the position of Shire President are to be made in writing before the meeting, or during the meeting prior to the close of nominations. If a Councillor is nominated by another Councillor, the person conducting the election is not to accept the nomination unless the nominee has advised the person conducting the election, verbally or in writing, that he or she is willing to be nominated.

The Council members are to vote on the matter by secret ballot as if they were voting in an election.

The Chief Executive Officer is to declare the result and the elected Shire President is to make a declaration pursuant to Regulation 13(3) of the *Local Government (Constitution) Regulations 1998*:

13. Oaths, Affirmations and Declarations (s. 2.29, 2.42)

- (3) *A declaration required by section 2.29 to be made by a person elected as a Councillor, Deputy Mayor or Deputy President is to be made before an authorised person.*

The Declaration of elected Shire President:

I _____ of _____, having been elected to the office of **Shire President** of the Shire of Lake Grace, declare that I take the office upon myself and will duly, faithfully, honestly, and with integrity, fulfil the duties of the office for the people in the district according to the best of my judgement and ability, and will observe the Local Government (Rules of Conduct) Regulations 2007.

The Declaration will be witnessed by the Chief Executive Officer.

The Chief Executive Officer will then hand the meeting over to the newly elected Shire President.

The Chief Executive Officer called for nominations for the office of the Shire President.

The Chief Executive Officer advised that at the close of nominations, one (1) nomination for the position of Shire President was received for Cr Len Armstrong.

The Chief Executive Officer declared Cr Len Armstrong duly elected as the Shire President

Cr Len Armstrong made the declaration pursuant to Regulation 13(3) of the Local Government (Constitution) Regulations 1998.

The Chief Executive Officer handed the meeting over to the newly elected Shire President at 2:39pm.

2.2 ELECTION OF DEPUTY SHIRE PRESIDENT

The Shire President is to call for nominations for the office of Deputy Shire President.

The Deputy Shire President is to be elected by the Council (including the Shire President) from amongst the Councillors.

Nominations for the position of Deputy Shire President are to be made in writing before the meeting, or during the meeting prior to the close of nominations. If a Councillor is nominated by another Councillor, the person conducting the election is not to accept the nomination unless the nominee has advised the person conducting the election, verbally or in writing, that he or she is willing to be nominated.

The Council members (including the Shire President) are to vote on the matter by secret ballot as if they were voting at an election. The Shire President is to declare the result and the elected

Deputy Shire President is to make a declaration pursuant to Regulation 13(3) of the *Local Government (Constitution) Regulations 1998*:

13. Oaths, affirmations and declarations (s. 2.29, 2.42)

(3) A declaration required by section 2.29 to be made by a person elected as a Councillor, Deputy Mayor or Deputy President is to be made before an authorised person.

The Declaration of elected Deputy Shire President:

I _____ of _____, having been elected to the office of **Deputy Shire President** of the Shire of Lake Grace, declare that I take the office upon myself and will duly, faithfully, honestly, and with integrity, fulfil the duties of the office for the people in the district according to the best of my judgement and ability, and will observe the *Local Government (Rules of Conduct) Regulations 2007*.

The Declaration will be witnessed by the Chief Executive Officer.

The Shire President advised that at the close of nominations, one (1) nomination for the position of Deputy Shire President was received.

The Shire President declared Cr Ross Chappell duly elected as the Deputy Shire President.

Cr Ross Chappell made the declaration pursuant to Regulation 13(3) of the *Local Government (Constitution) Regulations 1998*.

2.3 SEATING OF COUNCILLORS

A ballot will be conducted by the Chief Executive Officer for seating of Councillors in the Chambers. As per the *Shire of Lake Grace Standing Orders Local Law 2015*.

8.2 Members to occupy own seats

- (1) At the first meeting held after each election day, the CEO is to allot be random draw, a position at the Council table to each Member.*
- (2) Each member is to occupy his or her allotted position at each Council meeting.*

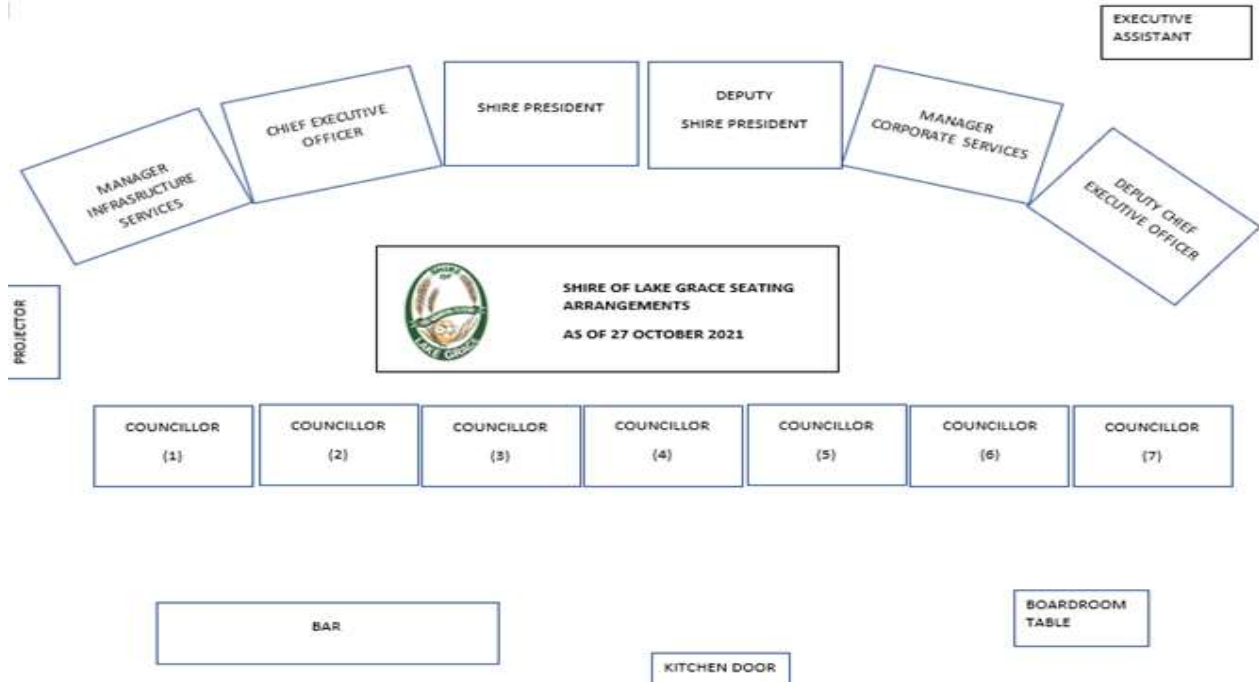

Councillors seating number / arrangement

- | | |
|----------------------------------|--------------------------------|
| Seat No. 1 - Cr Steve Hunt | Seat No. 5 – Cr Anton Kuchling |
| Seat No. 2 – Cr Roz Lloyd | Seat No. 6 – Cr Deb Clarke |
| Seat No. 3 – Cr Jeff McKenzie | Seat No. 7 – Cr Ben Hyde |
| Seat No. 4 – Cr Shane Carruthers | |

The Shire President invited Councillors to take their seats after the ballot.

2.4 DISCLAIMER READING AND ACKNOWLEDGMENT OF COUNTRY

No responsibility whatsoever is implied or accepted by the Shire of Lake Grace for any act, omission or statement or intimation occurring during Council and Committee meetings or during formal and informal conversations with staff. The Shire of Lake Grace disclaims any liability for any loss whatsoever caused arising out of reliance by any person or legal entity on any such act, omission or statement or intimation occurring during Council and Committee meetings or discussions. Any person or legal entity who acts or fails to act in reliance upon any statement does so at that person’s and or legal entity’s own risk.

In particular and without derogating in any way from the broad disclaimer above, in any discussion regarding any planning application or application for license, any statement or limitation or approval made by a member or officer of the Shire of Lake Grace during the course of any meeting is not intended to be and is not taken as notice of approval from the Shire of Lake Grace. The Shire of Lake Grace warns that anyone who has an application lodged with the Shire of Lake Grace must obtain and only should rely on WRITTEN CONFIRMATION of the outcome of the

application and any conditions attaching to the decision made by the Shire of Lake Grace in respect of the application.

Acknowledgement of Country to be read by the Shire President

The Shire of Lake Grace acknowledges and pays respect to the past, present and future Traditional Custodians and Elders of this nation and the continuation of cultural, spiritual and educational practices of Aboriginal and Torres Strait Islander people.

3.0 RECORD OF ATTENDANCE/APOLOGIES/LEAVE OF ABSENCE (PREVIOUSLY APPROVED)

3.1 PRESENT

Cr LW Armstrong	Shire President
Cr R Chappell	Deputy Shire President
Cr SD Carruthers	
Cr DS Clarke	
Cr SG Hunt	
Cr BJ Hyde	
Cr AJ Kuchling	
Cr RA Lloyd	
Cr JV McKenzie	

Apologies Nil

In Attendance

Mr A George	Chief Executive Officer
Mr C Paget	Deputy Chief Executive Officer
Mr C Elefsen	Manager Infrastructure Services
Mrs R Rose	Executive Assistant (for the Minutes)

Observers/Visitors Mr Andrew Walker
Mr Ollie Farrelly

3.2 APOLOGIES

Nil

3.3 LEAVE OF ABSENCE PREVIOUSLY GRANTED

Nil

4.0 RESPONSE TO PREVIOUS PUBLIC QUESTIONS TAKEN ON NOTICE

Nil

5.0 PUBLIC QUESTION TIME

Nil

6.0 PETITIONS/DEPUTATIONS/PRESENTATIONS

Nil

7.0 NOTATIONS OF INTEREST

Nil

7.1 DECLARATIONS OF FINANCIAL INTEREST – LOCAL GOVERNMENT ACT 1995 SECTION 5.60A

Cr Roz Lloyd declared Disclosure of Financial Interest (s5.65 Local Government Act 1995) on Item 14.4.4 – Newdegate 100 Year Centenary – Reserve Account. Cr Lloyd is a Committee Member and Treasurer of the Newdegate Historical Society.

7.2 DECLARATIONS OF FINANCIAL PROXIMITY INTEREST – LOCAL GOVERNMENT ACT 1995 SECTION 5.60B

Cr Shane Carruthers declared Disclosure of Proximity Interest (s5.65 Local Government Act 1995) on Item 14.1.1 – Unbudgeted Expenditure for Lake Grace Basketball Backboards and Rings. Cr Carruthers's Son is the author of the request.

7.3 DECLARATIONS OF IMPARTIALITY INTEREST – ADMINISTRATION REGULATIONS 1996 SECTION 34C

Cr Ross Chappell declared Disclosure of Interest Affecting Impartiality on Item 14.4.6 – Appointment of Authorised Persons – Shire of Lake Grace. Cr Chappell's wife Mrs Cheryl Chappell is a staff member and one of the nominated authorised persons.

Cr Anton Kuchling declared disclosure of Interest Affecting Impartiality on Item 14.4.6 – Appointment of Authorised Persons – Shire of Lake Grace. Cr Kuchling's wife Mrs Nicola Kuchling is a staff member and one of the nominated authorised persons.

8.0 APPLICATIONS FOR LEAVE OF ABSENCE

Nil

9.0 ANNOUNCEMENTS BY THE PRESIDING MEMBER WITHOUT DISCUSSION

Nil

10.0 CONFIRMATION OF MINUTES

Nil

10.1 ORDINARY COUNCIL MEETING - 29 SEPTEMBER 2021

RESOLUTION 13478

Moved Cr Chappell
Seconded Cr Hyde

That the Minutes of the Ordinary Council Meeting held on 29 September 2021 be confirmed as a true and accurate record of the meeting.

CARRIED: 9/0

10.2 SPECIAL COUNCIL MEETING

Nil

10.3 ANNUAL MEETING OF ELECTORS

Nil

11.0 MOTIONS OF WHICH PREVIOUS NOTICE HAS BEEN GIVEN

Nil

12.0 URGENT BUSINESS APPROVED BY THE PRESIDING MEMBER OR BY DECISION OF COUNCIL

Nil



13.0 REPORTS OF COMMITTEES

Nil

14.0 REPORTS OF OFFICERS

14.1 INFRASTRUCTURE SERVICES

14.1.1 UNBUDGETED EXPENDITURE FOR LAKE GRACE BASKETBALL BACKBOARDS AND RINGS

Applicant:	Shire of Lake Grace
File No.	0402
Attachments:	Letter from the Secretary – Lake Grace Basketball Association
Author:	 Ms Brooke Williamson Development Services Administration Officer
Disclosure of Interest	Nil
Date of Report	18 October 2021
Senior Officer	 Mr Craig Elefsen Manager Infrastructure Services

Cr Shane Carruthers declared a Disclosure of Proximity Interest (section 5.60b Local Government Act 1995) on this Item 14.1.1. Cr Carruthers's Son is the author of the request

Summary

For Council to authorise the unbudgeted expenditure of \$4,396.00 to reimburse Lake Grace Basketball Association for the replacement of weathered backboards and rings, funds to be transferred from job '1E0950700 – Lake Village Garden Maintenance MUN' to '113003 Lake Grace Rec Ground maintenance'.

Background

Due to the basketball rings and backboards being exposed to environmental factors, the equipment deteriorates more often than undercover equipment. Lake Grace Basketball Association has purchased new fibreglass boards and rings and have written to the Shire requesting reimbursement.

Comment

There is a 'Recreation Reserve' which currently has \$219,976.00 which the \$4,396.00 could be withdrawn from. Alternatively, there is \$12,022.76 that has been budgeted for Lakes Village

Garden Maintenance MUN which has \$0.00 spent to date. In the 2020/2021 financial year, \$11,332.00 was budgeted for the Lakes Village Garden and only \$4,215.42 totalled in expenditure. Given that history, there is expected to be spare money within that account in the 2021/2022 budget.

Councillor Ben Hyde and Cr Deb Clarke both queried the process and in future, such requests must go through a budget request rather than spending the money first and asked for reimbursement later.

Cr Len Armstrong's query – why is the funding coming from Garden Maintenance and not the Recreation Reserve?

Legal Implications

Local Government Act 1995

6.8. Expenditure from municipal fund not included in annual budget

- (1) A local government is not to incur expenditure from its municipal fund for an additional purpose except where the expenditure —
- (a) is incurred in a financial year before the adoption of the annual budget by the local government; or
 - (b) is authorised in advance by resolution*; or
 - (c) is authorised in advance by the mayor or president in an emergency.

** Absolute majority required.*

- (1a) In subsection (1) —

additional purpose means a purpose for which no expenditure estimate is included in the local government's annual budget.

- (2) Where expenditure has been incurred by a local government —

- (a) pursuant to subsection (1)(a), it is to be included in the annual budget for that financial year; and
- (b) pursuant to subsection (1)(c), it is to be reported to the next ordinary meeting of the council.

Policy Implications

Purchasing Policy 3.7

Consultation

Internal Mr Jason Lip Technical Officer

Financial Implications

Expense to be charged to '1E9050700 – Lakes Village Garden Maintenance MUN' which currently has \$12,022.76 allocated leaving \$7,222.76 remaining for the 2021/2022 financial year.

Strategic Implications

Shire of Lake Grace Strategic Community Plan 2017-2027

Social Objective – a valued, healthy and inclusive community and life-style

Outcomes 2.1 An engaged, supportive and inclusive community

2.1.1 Community services and infrastructure meeting the needs of the district

Voting Requirements

Absolute majority required.

RESOLUTION 13479

Moved Cr Hunt



Seconded Cr McKenzie

For Council to:

- Approve the transfer of \$4,396.00 from '1E9050700 Lakes Village Garden Maintenance MUN' to job '113003 Lake Grace Rec Ground maintenance';
- Approve the reimbursement of \$4,396.00 to the Lake Grace Basketball Association from '113003 Lake Grace Rec Ground Maintenance'.

CARRIED BY ABSOLUTE MAJORITY: 9/0

14.1.2 NEWDEGATE COUNTRY CLUB ALTERATIONS AND ADDITIONS

Applicant:	Trevenen Building and Glass Pty Ltd
File No.	0168 / 0830
Attachments:	Amended Timetable
Author:	 Mr Alan George Chief Executive Officer
Disclosure of Interest	Nil
Date of Report	18 October 2021
Senior Officer	 Mr Alan George Chief Executive Officer

Summary

Council approval is being sought to acknowledge the delays in the completion of the Newdegate Country Club Alterations and Additions project and to extend the completion date to 24 December, without penalty.

Background

Trevenen Building and Glass Pty Ltd were awarded the contract to carry out the works at the Newdegate Country Club. At the time of signing the contract, the completion date was set at 30 weeks from 1 May 2021 which was the anticipated possession date. The completion date was 26 November 2021.

Comment

Delays in obtaining the building permit resulted in the permit not being received until Friday 18 June with possession occurring on Wednesday 23 June. This coupled with unavoidable delays occurring due to a shortage of materials and availability of tradesmen has resulted in this request to extend the practical completion date to 24 December 2021.

If the actual possession date is taken into account, the extension to 24 December 2021 is under the 30-week timeline. Given the delays beyond the builders control, it is proposed not to impose the liquidated damages penalty rate for the extended completion date.

The amended program is attached.

Legal Implications

The contract may be amended subject to approval by all parties.

Policy Implications

Nil appropriate.

Consultation

Nil

Financial Implications

Nil at present.

Strategic Implications

Shire of Lake Grace Strategic Community Plan 2017-2027

Social Objective A valued, healthy and inclusive community and lifestyle

Outcome 2.1 An engaged, supportive and inclusive community

2.1.1 Community services and infrastructure meeting the needs of the district

2.1.2 Maintain and support the growth of education, childcare, youth and aged services

2.1.3 Actively promote and support community events and activities within the district

Outcome 2.2 A healthy and safe community

2.2.1 Maintain and enhance sport and recreation facilities

2.2.2 Provide and advocate for medical and health services

2.2.3 Support provision of emergency services and encourage community volunteers

Voting Requirements

Absolute majority required.

RESOLUTION 13480



Moved Cr Chappell

Seconded Cr Lloyd

That Council confirms the extension of the practical completion date of the Newdegate Country Club Alterations and Additions by Trevenen Building and Glass Pty Ltd to 24 December 2021, without the Liquidated Damages clause coming into effect.

CARRIED BY ABSOLUTE MAJORITY: 9/0

14.1.3 TRANSFER OF FUNDS – RURAL DRAINAGE WORKS

Applicant:	Internal Report
File No.:	0478
Attachments:	Nil
Author:	 Mr Jason Lip Technical Officer
Disclosure of Interest:	Nil
Date of Report:	19 October 2021
Senior Officer:	 Mr Craig Elefsen Manager Infrastructure Services

Summary

That Council authorises the transfer of \$70,000 from Job 1040101 "Urban Stormwater Drainage" to Job 122505 "Drainage".

Background

The Shire is responsible for the maintenance and renewal of public assets, roads and its associated drainage infrastructure included.

Drainage infrastructure on rural roads has a separate spending account to drainage infrastructure on urban roads (around and within townsite boundaries). This may also be split further by maintenance works and capital renewal/expansion works.

Currently, any culvert replacements are carried out by Roamin Enterprises, whom the Shire has a contract with for the provision of stormwater drainage maintenance services.

Comment

In the 2021/2022 Annual Budget, there is a Job 122505 "Drainage" set aside for rural drainage maintenance works which includes the replacement of damaged culverts. This also includes the purchase of pipes and cement and freighting from Perth to the Lake Grace Depot. Please note that spending on drainage maintenance works under this job only applies to works that are not already a part of a dedicated capital roadworks job.

Of this Job 122505, there is \$89,366.92 allocated. To date, \$12,931.93 has been spent, with another \$41,472.28 on order, leading to a combined total of \$54,404.21 committed. The amount left in this Job is \$34,962.71.

Initially, we thought that would be enough as its allocation and spending was based off 2020/2021 figures. However, the very wet 2021 year we have had has revealed many culverts in dire need

of attention; with the large influx of rain this year as compared to previous drought years. The stormwater has pushed out the silt and debris caking the insides of many culverts. This has led to culvert collapses from weakened helicoil culverts rusting due to being saturated with moisture for years, or old fibro culverts under designed for their location resulting in taking in more forceful water than it can handle, or being eaten away by salty soil condition.

It is expected that there will be many more culvert replacements that will need to be done in the 2021/2022 financial year; as having culvert collapses, leaving large holes in the middle of the road is very hazardous and these must be addressed as soon as we are alerted to one. However, we have almost reached the budget limit on this Job.

To resolve the limited budget, we would like to redirect money from Job 1040101 "Urban Stormwater Drainage". There is an allocation of \$135,805.20 for this Job, of which only \$36,128.28 has been committed. In the previous financial year, the total spend was \$60,033.64 which is less than half of this financial year's allocation. As there is no pressing concern with urban stormwater drainage infrastructure that we can see, it is proposed to transfer \$70,000.00 from this Job to 122505 "Drainage", where there are hazards that must be addressed immediately and in the future.

Legal Implications

Local Government Act 1995

6.8. Expenditure from municipal fund not included in annual budget

- (1) A local government is not to incur expenditure from its municipal fund for an additional purpose except where the expenditure —
 - (a) is incurred in a financial year before the adoption of the annual budget by the local government; or
 - (b) is authorised in advance by resolution*; or
 - (c) is authorised in advance by the mayor or president in an emergency.

** Absolute majority required.*

- (1a) In subsection (1) —

additional purpose means a purpose for which no expenditure estimate is included in the local government's annual budget.

- (2) Where expenditure has been incurred by a local government —
 - (a) pursuant to subsection (1)(a), it is to be included in the annual budget for that financial year; and
 - (b) pursuant to subsection (1)(c), it is to be reported to the next ordinary meeting of the council.

Policy Implications

Nil

Consultation

Internal: Mr Craig Elefsen - Manager Infrastructure Supervisor.

External: Mr Robert Davies - Roamin Enterprises.

Financial Implications

Accounts will be impacted as below:

Budget for 122505 "Drainage"	\$89,366.92
More Transfer of \$70,000 from 1040101 "Urban Stormwater Drainage"	\$70,000.00
Adjusted Budget for 122505 "Drainage"	\$159,366.92
Less Committed moneys under 122505 "Drainage"	-\$54,404.21
Adjusted remaining moneys in 122505 "Drainage"	\$104,962.71

Budget for 1040101 "Urban Stormwater Drainage"	\$135,805.20
Less Transfer of \$70,000 to 122505 "Drainage"	-\$70,000.00
Adjusted Budget for 1040101 "Urban Stormwater Drainage"	\$65,805.20
Less Committed moneys under 1040101 "Urban Stormwater Drainage"	-\$36,128.28
Adjusted remaining moneys in 1040101 "Urban Stormwater Drainage"	\$29,676.92

Strategic Implications

Shire of Lake Grace Strategic Community Plan 2017-2027

Economic Objective – A prosperous agricultural based economy, supporting diversification of industry

- Outcomes 1.1 An innovated, productive agriculture industry
 - 1.1.1 Enhance and maintain transport network
 - 1.1.2 Improve flood mitigation for transport infrastructure

Voting Requirements

Absolute majority required.



RESOLUTION 13481

Moved Cr Carruthers
Seconded Cr Clarke

That Council authorise the transfer of \$70,000.00 from Job 1040101 "Urban Stormwater Drainage" to Job 122505 "Drainage".

CARRIED BY ABSOLUTE MAJORITY: 9/0

14.1.4 UNBUDGETED EXPENDITURE – AIR COMPRESSOR FOR MEDICAL CENTRE

Applicant:	Dalyellup Dental
File No.:	0319
Attachments:	Nil
Author:	 Mr Jason Lip Technical Officer
Disclosure of Interest:	Nil
Date of Report:	20 October 2021
Senior Officer:	 Mr Craig Elefsen Manager Infrastructure Services

Summary

For Council to approve of the unbudgeted expenditure of a new air compressor for the Lake Grace Medical Centre's dental chair under Job B25CAP "Lake Grace Medical Centre – Cap Exp".

Background

Dalyellup Dental has requested a replacement of the air compressor that services the dental chair in the Lake Grace Medical Centre. The current air compressor is a very old "Captain" brand air compressor installed by Pulford Air Equipment, which no company is servicing this brand anymore in Western Australia.

Comment

As the old air compressor is unable to be serviced by an authorised contractor, and to stop the usage of decaying equipment whose condition is an unknown, Dalyellup Dental has sought quotes from medical equipment suppliers within WA for a new compressor. After speaking with a service person, it was recommended that Cattani branded air compressors for dental chairs (a Cattani AC200E in particular) would be suitable.

With that in mind and sorting through the quotes, there is one for the supply and install of a Cattani AC100 with an optional humid filter for around \$7,500 including GST (though all quotes were fairly similar in cost) which represents the best value in my opinion. Cattani air compressors come with a 7-year parts and labour warranty, and most companies who supply Cattani air compressors can also service them.

There is no allocation in the 2021/2022 Annual Budget for the replacement of the air compressor hence, Council approval to authorise the unallocated expenditure is sought. The Job B25CAP "Lake Grace Medical Centre – Cap Exp" has \$68,763.00 set aside for external painting, new solar battery, new vinyl flooring, new patio roofing, new chairs for the waiting room and a sink in the Nurse's room. To date, there is expenditure under this Job of \$15,909.09 for the solar battery, with other works forthcoming.

Money to cover this expenditure will be sourced from the Essential Medical Services Reserve, which currently holds \$559,058.43. Note that there is an expected transfer into this reserve of \$5,589.00 to occur this financial year.

Legal Implications

Local Government Act 1995

6.8. Expenditure from municipal fund not included in annual budget

- (1) A local government is not to incur expenditure from its municipal fund for an additional purpose except where the expenditure —
 - (a) is incurred in a financial year before the adoption of the annual budget by the local government; or
 - (b) is authorised in advance by resolution*; or
 - (c) is authorised in advance by the mayor or president in an emergency.

** Absolute majority required.*

(1a) In subsection (1) —

additional purpose means a purpose for which no expenditure estimate is included in the local government’s annual budget.

(2) Where expenditure has been incurred by a local government —

- (a) pursuant to subsection (1)(a), it is to be included in the annual budget for that financial year; and
- (b) pursuant to subsection (1)(c), it is to be reported to the next ordinary meeting of the council.

Policy Implications

Shire of Lake Grace Policy Manual – Policy 3.7 Purchasing Policy

Consultation

- Internal: Mr Craig Elefsen - Manager Infrastructure Supervisor
- External: Ms Anna Fleming - Dalyellup Dental
Mr Greg James - West Coast Dental

Financial Implications

An increase to the budget for B25CAP "Lake Grace Medical Centre – Cap Exp" of \$7,500.00 from \$68,763.00 to \$76,263.00. Please note those figures do not have a GST component.

The \$7,500.00 figure was calculated from the quote amount of \$7,500.00 without its GST component reducing it down to \$6,818.18, but the balance is brought back up to \$7,500.00 as a 10% contingency amount for the job.

Money will be sourced from the Essential Medical Services Reserve, which currently holds \$559,432.43. After transferring out \$7,500.00 to B25CAP, the reserve will hold \$551,932.43.

Strategic Implications

Shire of Lake Grace Strategic Community Plan 2017-2027

Social Objective – A valued, healthy and inclusive community and lifestyle

- Outcomes 2.2 A healthy and safe community
- 2.2.2 Provide and advocate for medical and health services

Voting Requirements

Absolute majority required.

RESOLUTION 13482

Moved Cr Lloyd
Seconded Cr Clarke

That Council authorise the transfer of \$7,500.00 from the Essential Medical Services Reserve to Job B25CAP “Lake Grace Medical Centre-Cap Exp” for the supply and installation of a new CATTANI AC100 Air Compressor.

CARRIED BY ABSOLUTE MAJORITY 9/0

14.2 PLANNING

Nil

14.3 HEALTH AND BUILDING

Nil

14.4 ADMINISTRATION

14.4.1 COUNCIL MEMBERSHIPS – SHIRE OF LAKE GRACE COMMITTEES OF COUNCIL

Applicant:	Internal Report
File No.:	0795
Attachments:	Council Committees and Advisory Groups Guide (Updated September 2021)
Author:	<i>RRRose</i> Mrs Racelis Rose Executive Assistant
Disclosure of Interest:	Nil
Date of Report:	04 October 2021
Senior Officer:	 Mr Chris Paget Deputy Chief Executive Officer

Summary

The Shire of Lake Grace Council to appoint members to Council Committees and External Organisations.

Background

After each Council election, the Shire of Lake Grace Council allocates positions to the Committees of Council, working advisory groups and representatives to external organisations. An Elected Member may request to be appointed to any Committee, Advisory Group or to represent Council on external organisation.

Comment

A “Council Committees and Advisory Groups Guide” developed in 2019 was updated in September 2021 (Attachment). Please note that this attachment contains the names of the Councillors whose committee tenures expires on 27 October 2021.

This Guide provides information relating to committees and advisory groups within the Shire of Lake Grace as they are established. This document includes the objectives, membership, duties and responsibilities of the official committee or an advisory group. It is amended on a need’s basis, naming those representatives appointed by Council and now, positions need to be allocated.

Legal Implications

Local Government Act 1995
Subdivision 2 – Committees and their meetings

5.8. Establishment of Committees

A local government may establish* committees of 3 or more persons to assist the council and to exercise the powers and discharge the duties of the local government that can be delegated to committees.

* Absolute majority required.

5.9. Committees, types of

- (1) In this section —
 - other person means a person who is not a council member or an employee.
- (2) A committee is to comprise —
 - (a) council members only; or
 - (b) council members and employees; or
 - (c) council members, employees and other persons; or
 - (d) council members and other persons; or
 - (e) employees and other persons; or
 - (f) other persons only.

5.10. Committee members, appointment of

- (1) A committee is to have as its members —
 - (a) persons appointed* by the local government to be members of the committee (other than those referred to in paragraph (b)); and
 - (b) persons who are appointed to be members of the committee under subsection (4) or (5).

* Absolute majority required.

- (2) At any given time each council member is entitled to be a member of at least one committee referred to in section 5.9(2)(a) or (b) and if a council member nominates himself or herself to be a member of such a committee or committees, the local government is to include that council member in the persons appointed under subsection (1)(a) to at least one of those committees as the local government decides.
- (3) Section 52 of the Interpretation Act 1984 applies to appointments of committee members other than those appointed under subsection (4) or (5) but any power exercised under section 52(1) of that Act can only be exercised on the decision of an absolute majority of the local government.
- (4) If at a meeting of the council a local government is to make an appointment to a committee that has or could have a council member as a member and the mayor or president informs the local government of his or her wish to be a member of the committee, the local government is to appoint the mayor or president to be a member of the committee.
- (5) If at a meeting of the council a local government is to make an appointment to a committee that has or will have an employee as a member and the CEO informs the local government of his or her wish —
 - (a) to be a member of the committee; or
 - (b) that a representative of the CEO be a member of the committee, the local government is to appoint the CEO or the CEO’s representative, as the case may be, to be a member of the committee.

Bush Fire Act 1954
Miscellaneous Part V

67. Advisory committees

- (1) A local government may at any time appoint such persons as it thinks fit as a bush fire advisory committee for the purpose of advising the local government regarding all matters relating to the preventing, controlling and extinguishing of bush fires, the planning of the layout of fire-breaks in the district, prosecutions for breaches of this Act, the formation of bush fire brigades and the grouping thereof under group brigade officers, the ensuring of co-operation and co-ordination of bush fire brigades in their efforts and activities, and any other matter relating to bush fire control whether of the same kind as, or a different kind from, those specified in this subsection.
- (2) A committee appointed under this section shall include a member of the council of the local government nominated by it for that purpose as a member of the committee, and the committee shall elect one of their number to be chairman thereof.
- (3) In respect to a committee so appointed, the local government shall fix the quorum for the transaction of business at meetings of the committee and may —
 - (a) make rules for the guidance of the committee; and
 - (b) accept the resignation in writing of, or remove, any member of the committee; and
 - (c) where for any reason a vacancy occurs in the office of a member of the committee, appoint a person to fill that vacancy.
- (4) A committee appointed under this section —
 - (a) may from time to time meet and adjourn as the committee thinks fit;
 - (b) shall not transact business at a meeting unless the quorum fixed by the local government is present;
 - (c) is answerable to the local government and shall, as and when required by the local government, report fully on its activities.

Emergency Management Act 2005

Local arrangements Part 3

Emergency management arrangements for local governments Division 2

38. Local emergency management committees

- (1) A local government is to establish one or more local emergency management committees for the local government's district.
- (2) If more than one local emergency management committee is established, the local government is to specify the area in respect of which the committee is to exercise its functions.
- (3) A local emergency management committee consists of —
 - (a) a chairman and other members appointed by the relevant local government in accordance with subsection (4); and
 - (b) if the local emergency coordinator is not appointed as chairman of the committee, the local emergency coordinator for the local government district.
- (4) Subject to this section, the constitution and procedures of a local emergency management committee, and the terms and conditions of appointment of members, are to be determined by the SEMC.

Policy Implications

Nil

Consultation

Internal Mr Alan George, Chief Executive Officer
 Mr Chris Paget, Deputy Chief Executive Officer
 Mr Matt Castaldini, Community Emergency Services Manager

Financial Implications

Elected Members attending other committee meetings may claim travel but no attendance fees are payable.

Non-Elected Member delegates representing the Shire are entitled to be reimbursed for travelling expenses incurred.

Strategic Implications

Shire of Lake Grace Strategic Community Plan 2017 - 2027
Social – A valued, healthy and inclusive community and life-style

Outcome 2.1 An engaged, supportive and inclusive community
 2.1.3 Actively promote and support community events and activities within the district

Leadership – Strong governance and leadership, demonstrating fair and equitable community values

Outcome 4.1 A strategically focused, unified Council functioning efficiently
 4.1.1 Provide informed leadership on behalf of the community
 4.1.2 Promote and advocate for the community and district
 4.1.3 Provide strategic leadership and governance

Voting Requirements

Absolute majority required.

RESOLUTION 13483

Moved Cr Chappell
Seconded Cr Hyde

That Council:

1. Appoint the following Elected Members as nominated representatives on the following Committees of Council;

Name of Committee	Names of Councillors
AUDIT COMMITTEE (AUC) (4 Councillors)	Cr Len Armstrong Cr Shane Carruthers Cr Steve Hunt Cr Debrah Clarke
NEWDEGATE REJUVENATION COMMITTEE (NRC) (4 Councillors)	

RESOLUTION 13484

Moved Cr Armstrong
Seconded Cr Carruthers

That Council disband the Newdegate Rejuvenation Committee (NRC) as the Terms of Reference is no longer relevant. Administration staff to present an agenda item and take up to the November 2021 Council meeting.

CARRIED BY ABSOLUTE MAJORITY: 9/0

LAKE GRACE LIBRARY RESOURCE & COMMUNITY RESOURCE MANAGEMENT COMMITTEE (LGLRCRMC) (1 Councillor)	Cr Debrah Clarke
NEWDEGATE LIBRARY RESOURCE & COMMUNITY RESOURCE MANAGEMENT COMMITTEE (NLRCRMC) (1 Councillor)	Cr Roz Lloyd
NEWDEGATE SWIMMING POOL MANAGEMENT COMMITTEE (NSPMC) (2 Councillors)	Cr Roz Lloyd Cr Len Armstrong

2. Appoint the following Elected Members on the following Committees formed by Council;

Name of Committee	Delegate	Deputy
LOCAL EMERGENCY MANAGEMENT COMMITTEE (LEMC) (2 Councillors)	Cr Len Armstrong	Cr Ross Chappell
BUSH FIRE ADVISORY COMMITTEE (BFAC) (2 Councillors)	Cr Ross Chappell	Cr Anton Kuchling

3. Appoint the following Elected Members as nominated representatives on the following Advisory Group formed by Council;

INTEGRATED PLANNING AND ASSET MANAGEMENT (IPAM) (4 Councillors)	Cr Ross Chappell Cr Len Armstrong Cr Ben Hyde Cr Anton Kuchling
SHIRE OF LAKE GRACE TOURISM ADVISORY COMMITTEE (SoLGTAC) (1 Councillor)	Cr Debrah Clarke

4. Appoint the following Elected Members as nominated representatives on the following external organisations;

Name of External Organisation	Delegate	Deputy
4WDL Regional Organisation of Councils	Cr Len Armstrong	Cr Ross Chappell
WALGA – Central Country Zone	Cr Len Armstrong	Cr Ross Chappell
Eastern Wheatbelt Biosecurity Group	Cr Len Armstrong	Cr Steve Hunt
Lake Grace District High School Board	Cr Jeff McKenzie	Cr Debrah Clarke
Lake Grace Roadwise	Cr Debrah Clarke	Cr Shane Carruthers
Lake King Grassed Oval Committee		

RESOLUTION 13485

Moved Cr Carruthers
Seconded Cr Lloyd

That Council disband the Lake King Grassed Oval Committee (LKGOC) as the Terms of Reference is no longer relevant. Administration staff to present an agenda item and take up to the November 2021 Council meeting.

CARRIED BY ABSOLUTE MAJORITY: 9/0

Name of External Organisation	Delegate	Deputy
Newdegate Recreation Council	Cr Roz Lloyd	Cr Len Armstrong
Roe Tourism	Cr Len Armstrong	Cr Debrah Clarke
Roe Regional Organisation of Councils Roe Health	Cr Len Armstrong	Cr Ross Chappell
Rural Water Council	Cr Len Armstrong	Cr Ross Chappell
Wheatbelt South Regional Road Group – Lakes Sub Group	Cr Len Armstrong	Cr Ross Chappell
Wheatbelt South Regional Road Group	Cr Len Armstrong	Cr Ross Chappell
Wheatbelt Development Assessment Panel	Cr Ross Chappell	Cr Len Armstrong
Wheatbelt Natural Resource Management	Cr Roz Lloyd	Cr Len Armstrong
Wheatbelt Railway Retention Alliance	Cr Len Armstrong	Cr Ross Chappell

CARRIED BY ABSOLUTE MAJORITY: 9/0

14.4.2 CHRISTMAS AND NEW YEAR 2021/2022 TRADING HOURS

Applicant:	Shire of Lake Grace
File No.	0817
Attachments:	Letter from the Department of Mines, Industry Regulation and Safety-Consumer Protection Division dated 23 September 2021
Author:	<i>RRRose</i> Mrs Racelis Rose Executive Assistant
Disclosure of Interest:	Nil
Date of Report:	30 September 2021
Senior Officer:	 Mr Alan George Chief Executive Officer

Summary

For Council to consider applying for an extension of trading hours over the 2021/2022 Christmas and New Year period.

Background

In previous years, a trading hour package based on the current Perth hours has been offered to regional Local Governments. However, the majority of Local Governments have declined the offer in the past and have applied for their own locally preferred Christmas/New Year trading arrangements.

From 2015 to 2019 the Shire adopted trading hours based on those in the metropolitan area, as listed below:

8.00am to 9.00pm	Monday to Friday
8.00am to 5.00pm	Saturday
11.00am to 5.00pm	Sunday
Christmas Day	Closed

In the notification to the Shire of Lake Grace's retailers, it has always stressed that, with all extended trading hour variations, the decision to open or not during the additional hours provided is at the retailers' discretion.

Comment

The Department of Mines, Industry Regulation and Safety-Consumer Protection Division recognises that metropolitan hours may not meet the needs of the local community, therefore, local governments that require amended trading hours need to consider their specific requirements and a proposal needs to be submitted with their application.

If Council does not support the extension of trading hours based on those in the metropolitan area, then an alternative recommendation would be that 'Council not support extended trading arrangements over the 2020/21 Christmas and New Year period'.

Legal Implications

Retail Trading Hours Act 1987

Part III Retail Trading Hours

12E. Variation of trading hours (1) The Minister may by order vary the trading hours of retail shops by — (a) requiring retail shops to be closed at a time or times when the shops would otherwise not be required to be closed under section 12(1) or (3), 12B or 12D; or (b) authorizing retail shops to be open at a time or times when the shops would otherwise be required to be closed under any of those provisions

Policy Implications

Nil

Consultation

Internal: Mr Alan George, Chief Executive Officer

Financial Implications

Nil

Strategic Implications

Shire of Lake Grace Strategic Community Plan 2017 - 2027

Economic Objective – A prosperous agricultural based economy, supporting diversification of industry

Outcome 1.2 A diverse and prosperous economy

1.2.2 Support local business and promote further investment in the district

Voting Requirements

Simple majority required.

RESOLUTION 13486

Moved Cr Chappell
 Seconded Cr Clarke

That Council seek approval from the Department of Commerce for extended trading hours for the Shire of Lake Grace over the 2021/ 2022 Christmas and New Year period, commencing from Monday 6 December 2021 and concluding on Saturday 1 January 2022, both dates are inclusive.

The hours will be as follows:

8:00 am to 9:00 pm	Monday to Friday
8:00 am to 5:00 pm	Saturday
11:00 am to 5:00 pm	Sunday and Public Holidays
Christmas Day	Closed

CARRIED 9/0



Government of Western Australia
 Department of Mines, Industry Regulation and Safety
 Consumer Protection

23 September 2021

Our Ref: 14895

Enquiries: Geoff Hales

Chief Executive Officer
 Shire of Lake Grace
 PO Box 50
 LAKE GRACE WA 6353

Shire of Lake Grace	
File No:	0496
30 SEP 2021	
Xref:	
Records #:	16135
Officer:	EA

DMIRS
FOR OCTOBER AGENDA PLEASE

Dear Sir or Madam,

2021-22 CHRISTMAS/ NEW YEAR RETAIL TRADING EXTENSIONS

The Department of Mines, Industry Regulation and Safety – Consumer Protection Division (Consumer Protection) invites you to consider applying for retail trading extensions within your locality, over the 2021-22 Christmas/New Year period.

Regional Local Governments that are yet to consider this issue are encouraged to do so at the earliest opportunity and where appropriate, formulate a Christmas trading proposal in accordance with local community needs.

Local Government's that wish to apply for an extension of retail trading hours over the 2020-21 Christmas/New Year period, should complete and submit the enclosed application form.

To enable sufficient time for processing please ensure your application is made before Friday 29 October 2021.

Should you have further queries in relation to this advice, please contact this office on (08) 6251 2466 or by email to geoff.hales@dmirs.wa.gov.au.

Yours sincerely

Geoff Hales
 A/PRINCIPAL COMPLIANCE OFFICER RETAIL TRADING
 AUTOMOTIVE, MARINE AND TRADING HOURS BRANCH

14.4.3 SCHEDULE OF COUNCIL MEETINGS – FEBRUARY TO DECEMBER 2022

Applicant:	Internal
File No.	0041
Attachments:	Public Notice 2022 Council Meetings
Author:	<i>RRRose</i> Mrs Racelis Rose Executive Assistant
Disclosure of Interest:	Nil
Date of Report:	5 October 2021
Senior Officer:	 Mr Alan George Chief Executive Officer

Summary / Background

Administration is seeking Council endorsement on the schedule of Council Meetings from February to December 2022.

In accordance with Policy 1.2 – Meeting Dates (Reviewed 23 June 2021 – Resolution No. 13425), Council is to meet on the fourth Wednesday of the months of February to December.

It is proposed that the Council meeting for the month of February 2022 be one week earlier, (16 February 2022) primarily because the gap between December 2021 and February 2022 is too big a gap.

The December 2022 meeting will be on 21 December 2022 because of the Christmas / New Year closure.

Comment

The following are the proposed Council meeting dates for 2022:

Date	Time	Place
Wednesday, 16 February 2022	3:30pm	Council Chambers, Lake Grace
Wednesday, 23 March 2022	3:30pm	Council Chambers, Lake Grace
Wednesday, 27 April 2022	3:30pm	Council Chambers, Lake Grace
Wednesday, 25 May 2022	3:30pm	Council Chambers, Lake Grace
Wednesday, 22 June 2022	3:30pm	Council Chambers, Lake Grace
Wednesday, 27 July 2022	3:30pm	Council Chambers, Lake Grace
Wednesday, 24 August 2022	3:30pm	Council Chambers, Lake Grace
Wednesday, 28 September 2022	3:30pm	Council Chambers, Lake Grace
Wednesday, 26 October 2022	3:30pm	Council Chambers, Lake Grace
Wednesday 23 November 2022	3:30pm	Council Chambers, Lake Grace
Wednesday 21 December 2022	3:30pm	Council Chambers, Lake Grace

Legal Implications

Nil

Policy Implications

Policy 1.2 – Meeting Dates

Council is to meet on the fourth Wednesday of the months of February to December.

A meeting in the month of January will only be held when it is called under the provision of section 5.4 of the Local government Act 1995.

Consultation

Internal

Mr Alan George – Chief Executive Officer

Mr Chris Paget – Deputy Chief Executive Officer

Financial Implications

Nil

Strategic Implications

Shire of Lake Grace Strategic Community Plan 2017-2027

Leadership Objective Strong governance and leadership, demonstrating fair and equitable community values

Outcomes 4.2 An efficient and effective organisation

4.1.1 Maintain accountability and financial responsibility through effective planning

Voting Requirements

Absolute majority required.

RESOLUTION 13487

Moved Cr Hyde



Seconded Cr Carruthers

That Council endorse the following schedule of Council Meetings from February to December 2022:

Date	Time	Place
Wednesday, 16 February	3:30pm	Council Chambers, Lake Grace
Wednesday, 23 March	3:30 pm	Council Chambers, Lake Grace
Wednesday, 27 April	3:30pm	Council Chambers, Lake Grace
Wednesday, 25 May	3:30pm	Council Chambers, Lake Grace
Wednesday, 22 June	3:30pm	Council Chambers, Lake Grace
Wednesday, 27 July	3:30pm	Council Chambers, Lake Grace
Wednesday, 24 August	3:30pm	Council Chambers, Lake Grace
Wednesday, 28 September	3:30pm	Council Chambers, Lake Grace
Wednesday, 26 October	3:30pm	Council Chambers, Lake Grace
Wednesday 23 November	3:30pm	Council Chambers, Lake Grace
Wednesday 21 December	3:30pm	Council Chambers, Lake Grace

CARRIED BY ABSOLUTE MAJORITY: 9/0

14.4.4 NEWDEGATE 100 YEAR CENTENARY – RESERVE ACCOUNT

Applicant:	Newdegate Centenary Committee
File No.:	Nil
Attachments:	Nil
Author:	 Mr Alan George Chief Executive Officer
Disclosure of Interest:	Nil
Date of Report:	14 October 2021
Senior Officer:	 Mr Alan George Chief Executive Officer

Cr Roz Lloyd declared a Disclosure of Financial Interest (section 5.65 Local Government Act 1995) on Item 14.4.4-Newdegate 100 Year Centenary – Reserve Account. Cr Lloyd is a Committee Member / Treasurer of the Newdegate Historical Society.

RESOLUTION 13488

Moved Cr Chappell
Seconded Cr Carruthers

That Cr Roz Lloyd remain in the room to listen to the discussion but will not be voting the resolution.

CARRIED BY ABSOLUTE MAJORITY: 8/0

Summary

For Council to approve the commencement of the release of funds from the Newdegate 100 Year Centenary Reserve account.

Background

The Newdegate Centenary celebrations will occur in September 2022. A Reserve Account was created to help cover the cost of staging the event, with a current balance of \$32,323.66.

Planning is now well underway with some costs coming through for deposits required for purchases of goods and services etc.

Comment

There has been no allocation made in the 2021/2022 budget for any funds to be disbursed from the reserve account.

In order to facilitate the purchases, a new general ledger account will need to be set up for this purpose. The Newdegate Centenary Committee will be co-ordinating the purchases and Shire Administration will be administering the release of the funds.

Additional funding will be provided by the Newdegate Field Days Committee along with some other sources.

Legal Implications

Local Government Act 1995 Part 6 - Financial Management

6.8. Expenditure from municipal fund not included in annual budget

- (1) A local government is not to incur expenditure from its municipal fund for an additional purpose except where the expenditure —
- (a) is incurred in a financial year before the adoption of the annual budget by the local government; or
 - (b) is authorised in advance by resolution*; or
 - (c) is authorised in advance by the mayor or president in an emergency.

* *Absolute majority required.*

- (1a) In subsection (1) —

additional purpose means a purpose for which no expenditure estimate is included in the local government's annual budget.

- (2) Where expenditure has been incurred by a local government —
- (a) pursuant to subsection (1)(a), it is to be included in the annual budget for that financial year; and
 - (b) pursuant to subsection (1)(c), it is to be reported to the next ordinary meeting of the council.

[Section 6.8 amended: No. 1 of 1998 s. 19.]

Policy Implications

Nil

Consultation

External Ms Stephanie Clarke Lloyd - Newdegate Centenary Committee

Financial Implications

There is no expenditure budget or account for these funds at present. The necessary budget will be put in place at the next Budget Review. Funding will be limited to the amount held in the Reserve with any further funding subject to Council approval in due course.

Strategic Implications

- Shire of Lake Grace Strategic Community Plan 2017-2027
- Social Objective A valued, healthy and inclusive community and lifestyle
- Outcome 2.1 An engaged, supportive and inclusive community
 - 2.1.1 Community services and infrastructure meeting the needs of the district
 - 2.1.2 Maintain and support the growth of education, childcare, youth and aged services
- 2.1. Actively promote and support community events and activities within the district

Voting Requirements

Absolute majority required.

RESOLUTION 13489



Moved Cr Carruthers
 Seconded Cr McKenzie

That Council:

1. Approves the release of funds from the Newdegate 100 Year Centenary Reserve account to assist with early preparation costs for the centenary in 2022.
2. The funds are to be released on the presentation of an invoice.
3. Funding will be limited to the balance of the Reserve account, currently \$32,343.

CARRIED BY ABSOLUTE MAJORITY: 8/0

14.4.5 RELATED PARTY DISCLOSURE POLICY

Applicant:	Internal Report
File No.:	0050
Attachments:	DRAFT – Policy 3.15 – Related Party Disclosures
Author:	 Mr Chris Paget Deputy Chief Executive Officer
Disclosure of Interest:	Nil
Date of Report:	22 October 2021
Senior Officer:	 Mr Alan George Chief Executive Officer

Summary

For Council to consider the new Related Party Disclosure policy for adoption.

Background

AASB 124 was issued by Australian Accounting Standards Board (AASB) in March 2015 and extended the Scope of AASB 124 to include application to all not-for-profit entities, which included Local Governments.

The operative date for Local Governments was set from 1 July 2016 (effectively to be reported for the year ended 30 June 2017). Whilst the Shire of Lake Grace introduced this element into its financial statements and thus complied with the new requirements back at that time, during the conduct of the recent Regulation 17 review and 2020-21 financial audit it has been identified by management and the auditors that no formal policy to recognise this reporting process was ever adopted by Council.

The objective of the standard is to ensure that an entity's financial statements contain disclosures necessary to draw attention to the possibility that its financial position and profit or loss may have been affected by the existence of related parties and transactions.

The disclosure requirements apply to the existence of relationships regardless of whether a transaction has occurred or not. For each financial year, the Shire must make an informed judgement as to who is considered to be a related party and what transactions need to be considered, when determining if disclosure is required.

Australian Accounting Standard AASB 124.2

This standard is applied in:

- Identifying related party transactions and relationships;

- Identifying outstanding balances including commitments between an entity and its related parties;
- Identifying circumstances in which disclosure of the above items are required;
- Determining the disclosures to be made about those items.

Purpose of Related Party Disclosures

AASB 124.5 to 124.8

Knowledge of related party transactions, outstanding balances and relationships is important to understanding and assessing an entity's operations.

Definitions

AASB 124.9 to 124.12

Definitions include related party, compensation, control, key management personnel, director and remuneration as well as some explanations and clarifications.

Key Definitions

Related Party Transaction:

A transfer of resources, services or obligations between a reporting entity and a related party, regardless of whether a price is charged.

Related Party:

A person or entity that is related to the local government that is preparing its financial statements.

A person or a close member of that person's family is related if that person:

- (not applicable to local government);
- Has significant influence over the reporting entity; or
- Is a member of the key management personnel of the reporting entity?

An entity is related if any of the following conditions applies:

- The entity and the reporting entity are members of the same group (which means that each parent, subsidiary and fellow subsidiary is related to the others) - may be applicable; or
- A person as identified above has significant influence ... or is a member of the key management personnel of the entity.

There are several relating to joint ventures and, in some circumstances, these may need to be considered.

Close members of the family of a person

Family members who may be expected to influence, or be influenced by, that person and include:

- Children and spouse or domestic partner;
- Children of that person's spouse or domestic partner; and
- Dependents of both in a) and b).

Key Management Personnel

Those persons having authority and responsibility for planning, directing and controlling the activities of the entity, directly or indirectly, including any director (whether executive or otherwise) of that entity. In the case of the Shire of Lake Grace this includes all Councillors and Senior Staff.

Senior Staff would include the CEO, Deputy CEO and any staff member at Manager Level. There may possibly also be the need to include the Works Supervisor, Environmental Health Officer, and Building or Planning Officer (if employed directly by the Shire) where they have direct responsibility for an operational area of the local government.

Substance Over Form

AASB 124.10

In considering each possible related party relationship, attention is directed to the substance of the relationship and not merely the legal form.

Comparatives

Transitional requirements discussed in the Basis for Conclusions at AASB 2015-6 BC32:

- The AASB decided not to require comparative related party disclosures to be presented in the period of initial application.
- Will mean you need to understand and start collecting from 1 July 2016 so year ended 30 June 2017 disclosure easier to find / support.

Disclosure

AASB 124.13 to 124.27

Includes:

- Relationships between parents and subsidiaries of the entity, regardless of whether there have been any transactions between the related parties (may be applicable to local government under new Regional Subsidiaries legislation);
- Information about key management personnel compensation in total and for certain categories;
- Certain information about transactions between related parties and any outstanding balances at reporting date for each type of related party; and
- Information about related entities.

Key Disclosure Requirements

AASB 124.17

A local government shall disclose key management personnel compensation in total and for each of the following categories:

- a) Short-term employee benefits
- b) Port-employment benefits
- c) Other long-term benefits
- d) Termination benefits
- e) Share-based payment

AASB 124.18

If the local government has had related party transactions during the periods covered by the financial statements, it shall disclose the nature of the related party relationship as well as information about those transactions and outstanding balances.

Describes minimum disclosure inclusions.

Comment

In accordance with the Department of Local Government's Guideline this policy is presented to Council for consideration of adoption.

Consultation

- Internal Mr Alan George - Chief Executive Officer
 Mr Kevin Wilson – former Manager Corporate Services

- External Paxon Group
 AMD – Shire Auditors
 Office of Auditor General WA

Statutory Environment

AASB 124
Local Government Act 1995 Division 6 – Disclosure of financial interests and gifts
Local Government (Financial Management) Regulations 1996

Policy Implications

New policy “Related Party Disclosures”

Financial Implications

Nil

Strategic Implications

- Shire of Lake Grace Strategic Community Plan 2017 - 2027
Leadership – Strong governance and leadership, demonstrating fair and equitable community values
- Outcome 4.1 A strategically focused, unified Council functioning efficiently
 - 4.1.1 Provide informed leadership on behalf of the community
 - 4.1.3 Provide strategic leadership and governance
 - Outcome 4.2 An efficient and effective organisation
 - 4.2.1 Maintain accountability and financial responsibility through effective planning
 - 4.2.2 Comply with statutory and legislative requirements

Voting Requirements

Simple majority required.



RESOLUTION 13490

Moved Cr Chappell
Seconded Cr Carruthers

That Council adopts the Related Party Disclosure Policy as presented.

CARRIED 9/0

14.4.6 APPOINTMENT OF AUTHORISED PERSONS – SHIRE OF LAKE GRACE

Applicant:	Internal Report
File No.:	Nil
Attachments:	Nil
Author:	 Mr Chris Paget Deputy Chief Executive Officer
Disclosure of Interest:	Nil
Date of Report:	22 October 2021
Senior Officer:	 Mr Alan George Chief Executive Officer

Please refer to Item 7.3 above – Declaration of Impartiality Interest – Administration Regulations 1996 Section 34c – Cr Kuchling and Cr Chappell both declared as Mrs Kuchling and Mrs Chappell are both employees of the Shire of Lake Grace and nominated as appointed officers.

Summary

The purpose of this report is for Council to appoint Authorised Persons to exercise power under the Local Government Act 1995, associated legislation and other Acts, on behalf of the Shire of Lake Grace.

Background

In accordance with a number of provisions of various Acts, Regulations and local laws, Council is required to appoint authorised persons to perform various authorised functions.

Authorisations are regularly reviewed and updated to reflect both legislation and staff changes; the last comprehensive review was previously undertaken and presented at the Ordinary Meeting of Council held 18 December 2019. Since this time, there has been a considerable turnover in staff members as well as an organisational restructure; it is now timely for Council to review and approve the new authorised persons. Note that the appointment of authorised persons under the requirements of the Bush Fires Act 1954 was previously approved by Council at the ordinary meeting held on Wednesday 29th September 2021.

Comment

- (1) Section 3.24 of the Local Government Act 1995 enables a local government to expressly authorise a person(s) to exercise its executive powers under the Act.

These authorisations relate to certain provisions about land, including issuance of notices requiring certain things to be done by an owner or occupier of land in accordance with Schedule 3.1 of the Act. These can include matters relating to drainage requirements, safety issues and unsightly land. It is proposed to appoint CEO Alan George, Deputy CEO Chris Paget and Manager Infrastructure Services Craig Elefsen.

- (2) Part 3, Division 3, Section 3.28 & 3.29 of the Local Government Act 1995 provides for Power of Entry, subject to notice and other than by a Local Law e.g. abandoned vehicles or home industry. For this purpose it is proposed to authorise CEO Alan George, Deputy CEO Chris Paget and Manager Infrastructure Services Craig Elefsen
- (3) Section 3.39 of the Local Government Act 1995 enables Council to appoint an authorised person for the purpose of removing or impounding of goods that are involved in a contravention, as prescribed by regulation or local law, that can lead to impounding. It is proposed that CEO Alan George, Deputy CEO Chris Paget and Manager Infrastructure Services Craig Elefsen are the authorised persons.
- (4) & (5) Part 9 of the Local Government Act 1995 provides for the appointment of authorised persons relating to enforcements and legal proceedings, i.e. the fining of a person committing an offence and the issuing of infringement notices. It is proposed that CEO Alan George, Deputy CEO Chris Paget and Manager Infrastructure Services Craig Elefsen are the authorised persons.
- (6) Section 37 of the Control of Vehicles (Off-road Areas) Act 1978 also deals with infringement notices. For the purposes of the above the following staff members are designated as Authorised Persons: CEO Alan George, Deputy CEO Chris Paget and Manager Infrastructure Services Craig Elefsen.
- (7) The extension of the payment period (s9.19) and/or the withdrawal of the notice (s9.20) is to be authorised by Chief Executive Officer, Alan George and Deputy Chief Executive Officer, Chris Paget.
- (8) In accordance with s449 of the Local Government (Miscellaneous Provisions) Act 1960, a local government may establish and maintain one or more public pounds and may appoint persons to be keepers of those pounds so as to have care, control and management of those pounds. MIS Craig Elefsen, Matthew Sharpe and Mornè Pfister are appointed as the Authorised Persons.
- (9) Pursuant to the Dog Act 1976 the local government is required to appoint an "Authorised Person" to exercise powers on behalf of the local government, under section 29(1) of this Act. The following staff members are appointed as an "Authorised Person":
 - Alan George
 - Chris Paget
 - Craig Elefsen
 - Matthew Sharpe
 - Mornè Pfister
- (10) Pursuant to the Dog Act 1976 the local government is required to appoint a "Registration Officer" to undertake the registration of dogs in accordance with the requirements of the Act. The following staff members are appointed as an authorised "Registration Officers":

- Nicola Kuchling
 - Cheryl Chappell
 - Brooke Williamson
 - Racelis Rose
 - Amber McPherson
- (11) Pursuant to the Cat Act 2011 the local government may, in writing, appoint persons or classes of persons to be authorised for the purposes of performing particular functions. Accordingly, the following staff members are appointed as an "Authorised Person":
- Alan George
 - Chris Paget
 - Craig Elefsen
 - Matthew Sharpe
 - Mornè Pfister
- (12) Pursuant to the Cat Act 2011 the local government may, in writing, appoint persons or classes of persons to be authorised for the purposes of performing particular functions. Accordingly, the following staff members are appointed as "Authorised Person – Registration Only":
- Alan George
 - Chris Paget
 - Craig Elefsen
 - Rebecca Clark
 - Nicola Kuchling
 - Cheryl Chappell
 - Brooke Williamson
 - Racelis Rose
 - Amber McPherson
- (13) Pursuant to s24 of the Public Health Act 2016 Council may appoint Environmental Health Officers and Authorised Officers to perform such duties as the local government from time to time directs and also such as are specifically prescribed by any order of the Executive Director, Public Health. Brendon Gerrard, Lauren Pitman and Barry Smith are the appointed Environmental Health Officers and Authorised Officers.
- (14) Pursuant to s17 of the Caravan Parks and Camping Grounds Act 1995 the Chief Executive Officer may appoint such persons to be authorised persons for the purposes of the Act. An authorised person may enter and inspect premises to ensure compliance with the requirements of the Act.
- The Chief Executive Officer has appointed Brendon Gerrard, Lauren Pitman and Barry Smith as authorised persons (Power of Entry and Inspection) for the purposes of s17 of the Caravan Parks and Camping Grounds Act 1995.
- (15) For the purposes of s26 of the Litter Act 1979 all Council Members, Shire Employees, Brendon Gerrard, Lauren Pitman, Barry Smith, Matthew Sharpe and Mornè Pfister are deemed to be authorised persons.

- (16) Section 122 of the Food Act 2008 requires the local government as the “Enforcement Agency” (refer Delegation H04) to appoint Authorised Officers in writing and issue certificates of authorisation. For the purposes of s122, Brendon Gerrard, Lauren Pitman and Barry Smith are the Shire’s Authorised Officers.
- (17) Section 126 of the Food Act 2008 requires the local government as the “Enforcement Agency” (refer Delegation H04) to appoint Designated Officers in writing and issue certificates of authorisation. For the purposes of s126, Brendon Gerrard, Lauren Pitman and Barry Smith are the Shire’s Designated Officers.
- (18) Under Section 96(3) of the Building Act 2011, a local government may appoint authorised persons in relation to buildings and incidental structures located or proposed to be located in the Shire (refer Delegation B01). Gary Bruhn is appointed as an authorised person.
- (19) Pursuant to the Health (Miscellaneous Provisions) Act 1911, and under Regulation 15D(5) of the Health (Asbestos) Regulations 1992, the local government may appoint officers who are authorised to issue infringement notices for the offences specified under Schedule 1 of those regulations. For the purposes of Regulation 15D(5), Brendon Gerrard, Lauren Pitman and Barry Smith are the Shire’s Authorised Officers.

Statutory / Legal Implications

Local Government Act 1995
 Local Government (Miscellaneous Provisions) Act 1960
 Bush Fires Act 1954
 Dog Act 1976
 Health (Miscellaneous Provisions) Act 1911
 Public Health Act 2016
 Health (Asbestos) Regulations 1992
 Litter Act 1979
 Control of Vehicles (Off-Road Areas) Act 1978
 Caravan Parks and Camping Grounds Act 1995
 Cemeteries Act 1986
 Cat Act 2011

Policy Implications

Nil

Consultation

Internal Mr Alan George – Chief Executive Officer

Strategic Implications

Shire of Lake Grace Strategic Community Plan 2017 - 2027
 Leadership – Strong governance and leadership, demonstrating fair and equitable community values.

Outcome	4.1	A strategically focused, unified Council functioning efficiently
	4.1.1	Provide informed leadership on behalf of the community

- 4.1.2 Promote and advocate for the community and district
- 4.1.3 Provide strategic leadership and governance
- Outcome 4.2 An efficient and effective organisation
 - 4.2.1 Maintain accountability and financial responsibility through effective planning
 - 4.2.2 Comply with statutory and legislative requirements
 - 4.2.3 Provide a positive and safe workplace

Voting Requirements

Simple majority required.



RESOLUTION 13491

Moved Cr Lloyd
Seconded Cr Hunt

That Council appoints the individuals listed in the report as “Authorised Persons” for the Shire of Lake Grace in accordance with the requirements of the specified Acts/Regulations effective 27 October 2021.

CARRIED 9/0

14.5 FINANCE**14.5.1 ACCOUNTS FOR PAYMENT – SEPTEMBER 2021**

Applicant	Internal Report
File No	0277
Attachments	List of Accounts Payable
Author	 Ms Rebecca Clark Finance Officer – Rates & Creditors
Disclosure of Interest	Nil
Date of Report	18 October 2021
Senior Officer	 Mr Chris Paget Deputy Chief Executive Officer

Summary

For Council to ratify expenditures incurred for the month of September 2021.

Background

List of payments for the month of September 2021 through the Municipal account is attached.

Comment

In accordance with the requirements of the Local Government Act 1995, a list of creditors is to be completed for each month showing:

- (a) The payee's name
- (b) The amount of the payment
- (c) Sufficient information to identify the transaction
- (d) The date of payment

The attached list meets the requirements of the Financial Management Regulations.

Legal Implications

Local Government (Financial Management) Regulations 1996 – Reg 12
Local Government (Financial Management) Regulations 1996 – Reg 13

Policy Implications

Policy 3.6 - Authorised Use of Credit Card/Fuel Cards
Policy 3.7 - Purchasing Policy

Consultation

N/A

Financial Implications

The list of creditors paid for the month of September 2021 from the Municipal and Trust Accounts total is \$863,899.85.

Strategic Implications

Shire of Lake Grace Strategic Community Plan 2017-2027
Leadership – Strong governance and leadership, demonstrating fair and equitable community values.

- Outcomes 4.2 An efficient and effective organisation
 - 4.2.1 Maintain accountability and financial responsibility through effective planning
 - 4.2.2 Comply with statutory and legislative requirements

Voting Requirements

Simple majority required.

RESOLUTION 13492

Moved Cr Hunt
Seconded Cr Hyde

That Council ratify the list of payments totalling \$863,899.85 as presented for the month of September 2021 incorporating:



Payment Method	Cheque/EFT/DD Number	Amount
Electronic Funds Transfers	EFT22620 - EFT22793	\$792,382.27
Municipal Account Cheques	36953 – 36957	\$644.02
Direct Debits	DD9663.1 – DD9706.1	\$70,873.56
	TOTAL	\$863,899.85

to the Municipal account, totalling \$863,899.85 which were submitted to each member of the Council on 27 October 2021, have been checked and fully supported by vouchers and invoices which are submitted herewith and which have been duly certified as to the receipt of goods and the rendition of services and as the prices, computations, and costings and the amounts show are due for payment.

Alan George
CHIEF EXECUTIVE OFFICER

CARRIED 9/0

14.5.2 FINANCIAL REPORTS – 30 SEPTEMBER 2021

Applicant	Internal Report
File No	0275
Attachments	<ul style="list-style-type: none"> • Monthly Financial Reports • Bank reconciliations – June 2021
Author	 Ms Victoria Fasano Finance Officer – Reporting and Investments
Disclosure of Interest	Nil
Date of Report	18 September 2021
Senior Officer	 Mr Chris Paget Deputy Chief Executive Officer

Summary

Consideration of the Monthly Financial Reports for the period ending 30 September 2021 and Bank Reconciliations for the month ending 30 September 2021.

Background

The provisions of the Local Government Act 1995 and associated regulations require a monthly financial report is presented at an Ordinary Council meeting within two (2) months of the period end date.

Comment

As at 30 September 2021, operating revenue over target by \$79,947 (1.41%) mostly due to Rates and Operating grants received earlier than budgeted. Interest earnings below target due to low interest rates.

Operating expenditure is under YTD budget by \$523,002 (19.08%) mainly due to Materials and contracts, employee and overhead cost down, but this is only the beginning of a new financial year and is expected.

The capital program is below the target by \$181,882. Capital grants and contributions are down due to bulk of Local Roads & Community and Drought & Community projects are not yet initiated/finalised, funds will be recognised later in financial year. Payments for property, plant and equipment on the other hand, exceed the budget due to slight speed-up in capital projects.

Cash at bank is similar to the corresponding period last year, an investment agreement for 3 term deposits with Bankwest is in place (total of \$5,502,735).

Outstanding rates is tracking well and have recovered 77.9% to date.
General debtor is \$34,443 with no major outstanding debts to follow up.

The monthly financial reports include the accompanying Local Government special purpose financial statements for the Shire of Lake Grace, which comprises the Statement of Financial Activity (by Statutory Reporting Program), a summary of significant accounting policies and other explanatory notes for the period ending 30 September 2021. The financial statements have been compiled to meet compliance with the Local Government Act 1995 and associated regulations.

The Shire of Lake Grace is responsible for the information contained in the financial statements and is responsible for maintenance of an appropriate accounting system in accordance with relevant legislation.

Legal Implications

Section 6.4 of the Local Governments Act 1995 provides for the preparation of financial reports.

In accordance with Regulation 34(5), a report on variances greater than the materiality threshold (\$5,000 or 10% whichever is greater) must be compiled and adopted by Council. As this report is composed at a program level, variance commentary considers the most significant items that comprise the variance.

Policy Implications

Nil

Consultation

Nil

Financial Implications

Nil

Strategic Implications

Shire of Lake Grace Strategic Community Plan 2017 - 2027

Leadership – Strong governance and leadership, demonstrating fair and equitable community values

Outcome 4.2 An efficient and effective organisation

4.2.1 Maintain accountability and financial responsibility through effective planning

4.2.2 Comply with statutory and legislative requirements

Voting requirements

Simple majority required.

RESOLUTION 13493

Moved Cr Carruthers
Seconded Cr Chappell

That Council, in accordance with *Regulation 34* of the *Local Government (Financial Management) Regulations 1996* receives the attached:

1. Statements of Financial activity for the period ended 30 September 2021
2. Municipal, Trust and Reserve Funds bank reconciliations for the period ended 31 August 2021

CARRIED 9/0

14.6 COMMUNITY SERVICES

Nil

15.0 QUESTIONS OF WHICH DUE NOTICE HAS BEEN GIVEN

Nil

16.0 INFORMATION BULLETIN – OCTOBER 2021

Applicant:	Internal Report
File No.	Nil
Attachments:	Information Bulletin
Author:	<i>RRRose</i> Mrs Racelis Rose Executive Assistant
Disclosure of Interest:	Nil
Date of Report:	20 October 2021
Senior Officer:	 Mr Chris Paget Deputy Chief Executive Officer

Summary

The purpose of the Information Bulletin is to keep Elected Members informed on matters of interest and importance to Council.

Background

The Information Bulletin Reports deal with monthly standing items and other information of a strategic nature relevant to Council.

Copies of other relevant Councillor information are distributed via email.

Comment

This month's Information Bulletin Report was emailed to Councillors.

The October 2021 Information Bulletin attachment include:

Reports:

- Infrastructure Services Report – September 2021
- Environmental Health Officer Report – September 2021
- Lake Grace Visitor Centre Report – October 2021
- Lake Grace Library Report and Statistics – October 2021
- Lake King Library Report and Statistics – October 2021
- Newdegate Library Report and Statistics – October 2021

Circulars, Media Releases, Newsletters, Letters:

- PHEOC Bulletin No. 81
- PHEOC Bulletin No. 82
- PHEOC Bulletin No. 83
- PHEOC Bulletin No.
- MINUTES – EWBG Annual General Meeting, EWBG Chair Report 2021, Annual Report

Legal Implications

Nil

Policy Implications

Nil

Consultation

Nil

Financial Implications

Nil

Strategic Implications

Shire of Lake Grace Strategic Community Plan 2017 – 2027

Leadership – Strong governance and leadership, demonstrating fair and equitable community values.

- Outcome 4.1 A strategically focused, unified Council functioning efficiently
- 4.1.1 Provide informed leadership on behalf of the community

- 4.1.2 Promote and advocate for the community and district
- 4.1.3 Provide strategic leadership and governance

- Outcome 4.2 An efficient and effective organisation
- 4.2.1 Maintain accountability and financial responsibility through effective planning
 - 4.2.2 Comply with statutory and legislative requirements

Voting Requirements

Simple majority required.

RESOLUTION 13494

Moved Cr Lloyd
Seconded Cr McKenzie

That Council accepts the Information Bulletin Report for October 2021.

CARRIED 9/0

17.0 CONFIDENTIAL ITEMS AS PER LOCAL GOVERNMENT ACT S5.23 (2)

RESOLUTION 13495

Moved Cr Chappell
Seconded Cr Carruthers

That Council meet behind closed doors at 3:46 pm to consider the confidential Item(s) in accordance with Section 3.7 of the Shire of Lake Grace Standing Orders Local Law 2015.

Item 17.1 Matters pertaining to Staff

This item and any attachments are confidential in accordance with Section 5.23(2)(a) of the Local Government Act 1995.

CARRIED 9/0

The Manager Infrastructure Services along with the visitors/observers - Mr Andrew Walker and Mr Ollie Farrelly left the Council Chambers at 3:47pm.

RESOLUTION 13496

Moved Cr Carruthers
Seconded Cr Chappell

That Council accept the recommendations contained in Confidential Item

Item 17.1 Matters Pertaining to Staff

CARRIED 9/0

RESOLUTION 13497

Moved Cr Chappell
Seconded Cr Clarke

That Council move from behind closed doors at 3:53pm and resume the meeting.

CARRIED 9/0

The Manager Infrastructure Services returned to the Council Chambers at 3:54pm to join the meeting and was advised of Council's decision.

18.0 DATE OF NEXT MEETING – 24 NOVEMBER 2021

The next Ordinary meeting of Council is scheduled to take place on Wednesday 24 November 2021 commencing at 3:30pm at the Council Chambers, 1 Bishop Street, Lake Grace.

19.0 CLOSURE

There being no further business, the Shire President closed the meeting at 3:55pm.

20.0 CERTIFICATION

I, Leonard William Armstrong certify that the Minutes of Meeting held on 27 October 2021 as shown were confirmed as a true record of that meeting.

Signature

Date

Shire of Lake Grace

TOURISM ADVISORY COUNCIL (SoLGTAC)

MINUTES

Monday 25 October 2021

Meeting Commencing at 10:00 am



Disclaimer

No responsibility whatsoever is implied or accepted by the Shire of Lake Grace for any act, omission or statement or intimation occurring during Council and Committee meetings or during formal and informal conversations with staff. The Shire of Lake Grace disclaims any liability for any loss whatsoever caused arising out of reliance by any person or legal entity on any such act, omission or statement or intimation occurring during Council and Committee meetings or discussions. Any person or legal entity who acts or fails to act in reliance upon any statement does so at that person's and or legal entity's own risk.

In particular and without derogating in any way from the broad disclaimer above, in any discussion regarding any planning application or application for license, any statement or limitation or approval made by a member or officer of the Shire of Lake Grace during the course of any meeting is not intended to be and is not taken as notice of approval from the Shire of Lake Grace. The Shire of Lake Grace warns that anyone who has an application lodged with the Shire of Lake Grace must obtain and only should rely on WRITTEN CONFIRMATION of the outcome of the application and any conditions attaching to the decision made by the Shire of Lake Grace in respect of the application.

Acknowledgement of Country to be read by the Chairperson

The Shire of Lake Grace acknowledges and pays respect to the past, present and future Traditional Custodians and Elders of this nation and the continuation of cultural, spiritual and educational practices of Aboriginal and Torres Strait Islander people.

CONTENTS

CONTENTS	1
1.0 DECLARATION OF OPENING & ANNOUNCEMENT OF VISITORS	2
2.0 RECORD OF ATTENDANCE/APOLOGIES/LEAVE OF ABSENCE (PREVIOUSLY APPROVED)	2
2.1 PRESENT	Error! Bookmark not defined.
2.2 APOLOGIES	Error! Bookmark not defined.
2.3 LEAVE OF ABSENCE PREVIOUSLY GRANTED	2
3.0 PETITIONS / DEPUTATIONS / PRESENTATIONS / SUBMISSIONS	2
4.0 DECLARATIONS OF INTEREST	3
4.1 DECLARATIONS OF FINANCIAL INTEREST – LOCAL GOVERNMENT ACT 1995 SECTION 5.60A	3
4.2 DECLARATIONS OF PROXIMITY INTEREST – LOCAL GOVERNMENT ACT 1995 SECTION 5.60B	3
4.3 DECLARATIONS OF IMPARTIALITY INTEREST – ADMINISTRATION REGULATIONS 1996 SECTION 34C	3
5.0 APPLICATIONS FOR LEAVE OF ABSENCE	3
6.0 CONFIRMATION OF PREVIOUS MEETINGS	3
7.0 MOTIONS OF WHICH NOTICE HAS BEEN RECEIVED	3
8.0 NOTICES OF URGENT BUSINESS	3
9.0 MEMBERS REPORTS	3
10.0 MATTERS FOR CONSIDERATION	4
11.0 OTHER BUSINESS	4
12.0 DATES OF THE NEXT MEETINGS	5
13.0 CLOSURE	5

SHIRE OF LAKE GRACE

Minutes of the Shire of Lake Grace Tourism Advisory Committee Meeting held at the Council Chambers, Shire of Lake Grace, 1 Bishop Street, Lake Grace on Monday 25 October 2021.

1.0 DECLARATION OF OPENING & ANNOUNCEMENT OF VISITORS

The Acting Chairperson opened the Meeting at 10:06 am.

2.0 RECORD OF ATTENDANCE/APOLOGIES/LEAVE OF ABSENCE (PREVIOUSLY APPROVED)

2.1 ATTENDANCE

Present:

Committee Members:

Cr Debrah Clarke (DC)	Shire of Lake Grace - Councillor Representative
Ms Suzanne Reeves (SR)	Community Representative – Lake Grace
Ms Catherine Kelly (CK)	Community Representative – Newdegate
Ms Sheenah Zurnamer(SZ)	Community Representative – Lake King
Ms Carla Hyde(CH)	Community Representative - Varley

Shire of Lake Grace

Mr C Paget (CP)	Deputy Chief Executive Officer – Acting Chairperson
Ms J Morgan (JM)	Lake Grace Visitor Centre Coordinator
Ms V O’Neil-Gray (VOG)	Lake Grace Visitor Centre Coordinator

Apologies:

2.2 URGENT BUSINESS APPROVED BY PRESIDING MEMBER OR BY DECISION OF THE COMMITTEE

The Committee selected MS CATHERINE KELLY as the Chairperson of the Shire of Lake Grace Tourism Advisory Committee (SoLGTAC) with MS SUZANNE REEVES being the Vice Chairperson.

The Acting Chairperson handed the meeting over to the newly selected Chairperson.

2.3 LEAVE OF ABSENCE PREVIOUSLY GRANTED

Nil

3.0 PETITIONS / DEPUTATIONS / PRESENTATIONS / SUBMISSIONS

Nil

4.0 DECLARATIONS OF INTEREST

Nil

4.1 DECLARATIONS OF FINANCIAL INTEREST – LOCAL GOVERNMENT ACT 1995 SECTION 5.60A

Nil

4.2 DECLARATIONS OF PROXIMITY INTEREST – LOCAL GOVERNMENT ACT 1995 SECTION 5.60B

Nil

4.3 DECLARATIONS OF IMPARTIALITY INTEREST – ADMINISTRATION REGULATIONS 1996 SECTION 34C

Nil

5.0 APPLICATIONS FOR LEAVE OF ABSENCE

6.0 CONFIRMATION OF PREVIOUS MEETINGS

RESOLUTION 001

Moved: Ms Sheena Zurnamer

Seconded: Ms Vicki O'Neil Gray

That the Minutes of the Shire of Lake Grace Tourism Advisory Committee (formerly Lake Grace Visitor Centre Committee) held on 15 September 2021 be accepted as a true and accurate record of that meeting.

CARRIED: 8/0

7.0 MOTIONS OF WHICH NOTICE HAS BEEN RECEIVED

Nil

8.0 NOTICES OF URGENT BUSINESS

Nil

9.0 MEMBERS REPORTS

Nil

10.0 MATTERS FOR CONSIDERATION

Nil

11.0 OTHER BUSINESS

Tourism items were discussed during this meeting:

- Oceans Outback Brochure (Collie to Esperance) – needs to be updated, reproduced or made into a device application. Confusion over which map/brochure Cr Clarke is referring to, Jo has obtained quotes for the brochures.
- Optus Antenna – It was reported by the DCEO that Freed Solutions Group plans to install sometime in the future antennas from Wagin, Nyabing to Lake Grace. Question was asked if the Visitor Centre can also get an antenna.
- Walk Trails – follow up is to be made about the details of the presenter from Roe Tourism minutes of meeting. Mr Arthur Slarke sent notes from a recent Walk Trail conference he attended in Albany and DCEO will follow up with minutes.
- Jam Patch – waiting for toilet completion details.
- Playground Trails and Geocache Trails are needed, Ms Carla Hyde will have a chat to Ms Sarah Clarke for further information on Geocaching.
- Varley Donation box at Free Camping area, Carla Hyde and Jo Morgan still to add donation bank details.
- Wildflower photos to be tagged on publications made
- Advertisement of Shire events on public toilets just like the Shire of Kulin\
- Query to be made during the 4WDL meeting regarding the Collie to Lake King book

Ms Jo Morgan left the meeting at 11:00 am and did not return.

- Geocache at Dragon Rock has to be checked of its existence, Committee members are encouraged to do a check before the next meeting.
- The Varley sign needs to be updated and CH will send measurements to the LG Visitor Centre to facilitate – JM to follow up status.
- Scanning of “Across the Lake” is almost complete, this is a project of the LG Visitor Centre for the 2021/2022
- A Status Report of all the actions being discussed every meeting will need to be updated and presented during each meeting.

12.0 DATES OF THE NEXT MEETINGS

The SoLGTAC decided on the future meetings of the Committee as follows:

- Monday 7 February 2022 at 10:00am
- Monday 4 April 2022 at 10:00 am

13.0 CLOSURE

There being no further business, the Chairperson closed the meeting at 11:23 am.

13.0 CERTIFICATION

I, Catherine Kelly certify that the Minutes of Meeting held on 25 October 2021 as shown were confirmed as a true record of that meeting.

Signature

Date

SHIRE OF LAKE GRACE TOURISM ADVISORY COMMITTEE (SoLGTAC) MEETING

STATUS REPORT (ACTION ITEMS)

Status: **P – In Progress** **C – Completed** **N – Not Applicable** **NFA – No further Action**

Date of Meeting – 25 October 2021:

Item No	Description of Action	Action by	Status
1.	Confirm the Ocean to Outback brochure	Jo Morgan	
2.	Optus Antenna – find out solution to the possible installation of antennas and wireless network	Chris Paget	
3.	Possibility of obtaining antenna for the Visitor Centre	Chris Paget	
4.	Follow up with Roe Tourism presenter details for the Walk Trail	Vicki O Neil-Grey	
5.	Follow up completion of Jam Patch toilet		
6.	Follow up with Sarah Clarke – Playground Trails and Geocache Trails	Carla Hyde	
7.	Add donation bank details – Varley Donation box at Free Camping area	Jo Morgan & Carla Hyde	
8.	Tagging of Wildflower photos – ask Judy Garlick	Vicki O Neil-Grey	
9.	Advertisement of shire events on public toilets similar to the Shire of Kulin	Cathie Kelly	

10.	Ask about the “collie to Lake King” book at the 4WDL meeting and Oceans to Outback brochure	Jo Morgan	
11.	Investigate Geocache at Dragon Rock – take a drive to the area	All Committee members	
12.	Update VARLEY sign, send measurements to Visitor Centre and follow up	Carla Hyde & Jo Morgan	
13.	Promote the area near Duckworth Road, repair furniture (Steph Clarke)	Jo Morgan and Vicki O Neil Grey	

Shire of Lake Grace

Lake Grace Library Resource & Community Resource Centre Management Committee

Minutes

26 October 2021

Disclaimer

No responsibility whatsoever is implied or accepted by the Shire of Lake Grace for any act, omission or statement or intimation occurring during Council/Committee meetings or during formal/informal conversations with staff. The Shire of Lake Grace disclaims any liability for any loss whatsoever caused arising out of reliance by any person or legal entity on any such act, omission or statement or intimation occurring during Council/Committee meetings or discussions. Any person or legal entity who acts or fails to act in reliance upon any statement does so at that person's and or legal entity's own risk.

In particular and without derogating in any way from the broad disclaimer above, in any discussion regarding any planning application or application for license, any statement or limitation or approval made by a member or officer of the Shire of Lake Grace during the course of any meeting is not intended to be and is not taken as notice of approval from the Shire of Lake Grace. The Shire of Lake Grace warns that anyone who has an application lodged with the Shire of Lake Grace must obtain and only should rely on WRITTEN CONFIRMATION of the outcome of the application and any conditions attaching to the decision made by the Shire of Lake Grace in respect of the application.



CONTENTS

- 1.0 DECLARATION OF OPENING & ANNOUNCEMENT OF VISITORS 2**
- 2.0 RECORD OF ATTENDANCE / APOLOGIES.....ERROR! BOOKMARK NOT DEFINED.**
- 2.1 PRESENT Error! Bookmark not defined.**
- 2.2 APOLOGIES..... Error! Bookmark not defined.**
- 3.0 CONFIRMATION OF PREVIOUS MEETINGS.....2**
- 3.1 LAKE GRACE LIBRARY RESOURCE AND COMMUNITY RESOURCE CENTRE MANAGEMENT COMMITTEE MEETING.....2**
- 4.0 LAKE GRACE LIBRARY RESOURCE AND COMMUNITY RESOURCE CENTRE MANAGEMENT COMMITTEE MEETING REPORTS.....3**
- 4.1 LAKE GRACE LIBRARY REPORT 3**
- 4.2 LAKE GRACE COMMUNITY RESOURCE CENTRE REPORT 3**
- 4.3 LAKE GRACE COMMUNITY RESOURCE CENTRE SEMINAR ROOM FINANCIAL REPORT 4**
- 5.0 MATTERS FOR CONSIDERATION 4**
- 6.0 OTHER BUSINESS 4**
- 7.0 DATE OF THE NEXT MEETING 4**
- 7.1 LAKE GRACE LIBRARY RESOURCE AND COMMUNITY RESOURCE COMMITTEE MEETING 4**
- 8.0 CLOSURE 4**

SHIRE OF LAKE GRACE

Minutes for the Lake Grace Library Resource & Community Resource Centre Management Committee Meeting held at the Lake Grace Community Library, School Place, Lake Grace on Tuesday 26 October 2021.

1.0 DECLARATION OF OPENING & ANNOUNCEMENT OF VISITORS

The Chairperson opened the Meeting opened at 11:00am

2.0 RECORD OF ATTENDANCE/APOLOGIES/LEAVE OF ABSENCE (PREVIOUSLY APPROVED)

2.1 PRESENT

Mr Scott Tapper	Chairperson, Principal, Lake Grace District High School
Mrs Michelle Lay	School Administrator, Lake Grace District High School
Mr Chris Paget	Deputy Chief Executive Officer, Shire of Lake Grace
Cr Debrah Clarke	Shire of Lake Grace Council Representative
Mrs Suzanne Reeves	Manager, Lake Grace Community Resource Centre
Mr Ollie Farrelly	Community Representative
Mrs Lois Dickins	Co-ordinator, Lake Grace Library

2.2 APOLOGIES

Nil

3.0 CONFIRMATION OF PREVIOUS MEETINGS

3.1 LAKE GRACE LIBRARY RESOURCE AND COMMUNITY RESOURCE CENTRE MANAGEMENT COMMITTEE MEETING

RESOLUTION 20217

Moved: Michelle Lay

Seconded: Suzanne Reeves

That the minutes of the Lake Grace Library Resource and Community Resource Centre Management Committee Meeting held on 3 August 2021 be confirmed as a true and accurate record.

CARRIED 6/0

4.0 MEMBERS REPORTS

4.1 LAKE GRACE LIBRARY RESOURCE REPORT

Accessioning, book exchange and VDX are all up to date.

I have started using/playing with a trial program of our new library system, Oliverv5. I had little know how and help to start with but have since spoken to a lady from Softlink (IT Help) who sent information and instructions via email and then rang me. I have also had one hour of training. I hope to go live after the book fair. With the new system, accessioning will be done in three to four steps on the same page whereas now there is about 28 steps on multiple screens. 😊

The school has purchased over 80 new junior, fiction and non-fiction, books for the library. Most of them have been accessioned and put out on display.

I have received new books from Larrikin House using Book Fair credits.

The Scholastic Book Fair started yesterday, Monday 25 October, and runs until Thursday 4 November 2021.

Side student Neha Dwarakanath is still working in the library office. She has exams next week.

Students are still using the library at recess and lunch times.

Statistics since the last meeting:

Aug 2021	Issues & Renewals	627	Borrower Visits	374
Sept 2021	Issues & Renewals	342	“ “	138

4.2 LAKE GRACE RESOURCE CENTRE REPORT

We have been busy with the Lakes Link and only have four left for the year; we have made some changes to cost of advertising for our not for profits – as it was our NFPs who are members had no benefit in cost so we have altered the pricing structure to give them more benefits. We are incredibly well supported for advertising, we just need more articles of local interest.

Crochet has been well attended for Fridays and a date has been set for the handover of the blankets. We held another forklift in September and also a Piloting workshop. We won't be scheduling any more workshops until 2022. Have started taking bookings for stalls for the Harvest Festival, entertainment is organized as is the road closure.

All is going steadily with our partnerships:

- We have held a couple of busy bees for the Bushcare project with the LCDC, there is a school incursion being held today.
- Men's Shed held their AGM last week, there has been little change in the committee.
- Roadwise – had the Driver Reviver open for the Queen's birthday and we're looking forward to having a permanent site at the recreation precinct.

- Community Bus. Had a committee meeting recently and we have been moving forward toward getting a new bus. All is going well with the management side and we have been getting quite a few bookings.

I have caught up on acquitting all of the CRC grants and have a couple in the pipeline that we're waiting to hear about.

We have just taken delivery of a new computer for the main office.

4.3 LAKE GRACE COMMUNITY RESOURCE CENTRE SEMINAR ROOM FINANCIAL REPORT

3/08/2021 — 26/10/2021

Seminar Room Hire Account Reconciliation:

Balance of Seminar Room Account 3/8/2021		\$1,917.54
22/09/21 Venue Hire (July-August)	\$20.45	<u>\$1,937.99</u>

Seminar Room Bank Account Statement Reconciliation:

Balance of September 30th Bank Statement		\$1,937.99
Less Unpresented payments	\$0	\$1,937.99
Plus Unrecorded deposits	\$0	<u>\$1,937.99</u>

5.0 MATTERS FOR CONSIDERATION

Nil

6.0 OTHER BUSINESS

A reminder to let the CRC and Library know of all power and water outages.

7.0 DATE OF THE NEXT MEETING

The next Lake Grace Library Resource and Community Resource Centre Management Committee Meeting is scheduled to take place on Tuesday 8 March 2022, commencing at 11:00am at the Lake Grace Community Library, School Place, Lake Grace.

7.1 LAKE GRACE LIBRARY RESOURCE AND COMMUNITY RESOURCE CENTRE COMMITTEE MEETING

Recommendation that the 2022 meeting dates for the Lake Grace Community Library and Community Resource Centre Management Committee be confirmed as:

Tuesday 8 March 2022, Tuesday 17 May 2022, Tuesday 2 August 2022, Tuesday 25 October 2022.

8.0 CLOSURE

There being no further business, the Chairperson closed the meeting at 11:16am.

9.0 CERTIFICATION

I, Scott Tapper certify that the minutes of the meeting held on the 3 August 2021 as shown were confirmed as a true record at the meeting held on 26 October 2021.

Presiding Member



Date 26/10/2021



ABN 26 373 259 082

14 Cobbold Lane
MAROOCHYDORE QLD 4558

0418 405 006

8 October 2021

**Attachment - Item 14.2.1 Development Application Willcocks
Road, South Lake Grace**

The Chief Executive Officer
The Shire of Lake Grace
Via email: shire@lakegrace.wa.gov.au

Dear Sir / Madam

RE: DEVELOPMENT APPLICATION FOR PROPOSED TELECOMMUNICATIONS FACILITY
Lot 13069 on DP206385
Willcocks Road, South Lake Grace

Out of the Woods Planning acts on behalf of the Applicant, Field Solutions Group, and we submit herewith a Development Application for a proposed Telecommunications Facility over the above referenced land for consideration by Council.

The subject land is located in the General Agriculture Zone and, under the Zoning Table, a Telecommunications Facility in the General Agriculture Zone is Discretionary.

Would Council please provide an invoice for the development application fee and our client will pay Council directly?

We choose to lodge this application electronically and it would be appreciated if all correspondence to do with this application please be sent by email.

Application for Development Approval form and Owner's Consent are attached as well as other supporting documents. Please note that an EME Report has not been provided because the proposed telecommunications facility is for wireless broadband only and does not transmit electromagnetic waves/fields to mobile phones and therefore does not emit electromagnetic radiation.

We trust the details of the Development Application set out above and attached are satisfactory.

Thank you for your consideration and please do not hesitate to contact the writer if further information is required.

Yours Sincerely

Wendy Wood | Principal

The Shire of Lake Grace
Via email: shire@lakegrace.wa.gov.au

Dear Sir / Madam

RE: DEVELOPMENT APPLICATION FOR PROPOSED TELECOMMUNICATIONS FACILITY
Lot 13069 on DP206385
Willcocks Road, South Lake Grace

Out of the Woods Planning has been engaged by Field Solutions Group to manage the development planning for a telecommunications facility proposed on the abovementioned land. The proposed facility is part of a wide network to be located throughout Western Australia to provide coverage to regional and remote areas.

An agreement has been entered into with the landowner for installation of telecommunications infrastructure to be located on the subject land in the form of a 45m telecommunications tower and associated infrastructure.

This development application is made in accordance with the *Planning and Development Act 2005* for assessment under the *Lake Grace Local Planning Scheme No. 4*. The subject land is located in the General Agriculture Zone and, under the Zoning Table, a Telecommunications Facility in the General Agriculture Zone is Discretionary.

A telecommunications facility can be properly defined under the planning scheme, thus:

“telecommunications infrastructure” means premises used to accommodate the infrastructure used by or in connection with a telecommunications network including any line, equipment, apparatus, tower, antenna, tunnel, duct, hole, pit or other structure related to the network;

In support of the application, we provide the following:

Attachment	Document
1	Application for Development Approval Form
2	Owner's Consent
3	Certificate of Title Search
4	Deposited Plan 206385
5	Site Plan
6	45m Tower Technical Drawing
7	Antenna Infrastructure



The Subject Land

We provide an overview of the subject land in the table below:

Address of Subject Land	Willcocks Road, South Lake Grace
Real Property Description	Lot 13069 on DP206385
Area of Subject Land	1022.3346 hectares
Existing buildings	None (cropping land)
Road frontages	Willcocks Road
Zone	General Agriculture Zone
Overlays	Bushfire Prone Area, Native Vegetation
Name of Landowner	Kim Charles Slarke, Michelle Jane Slarke
Easements/Encumbrances	None

The subject land is located on Willcocks Road, South Lake Grace and is approximately 14km by road south east of Lake Grace.

The subject land is identified as being located within the General Agriculture Zone according to Local Planning Scheme Map No. 1 as shown in Figure 1 below and is used for cropping.

The subject land has a frontage to Willcocks Road which is a 15m wide gravel road.

The subject land is located in a Bushfire Prone Area as shown in Figure 2 below and contains native vegetation as shown in Figure 3 below.

There are no reticulated services to the subject land other than electricity.

Figure 1: Local Planning Scheme Map 1 Lake Grace North West | Source: Shire of Lake Grace Local Planning Scheme No. 4

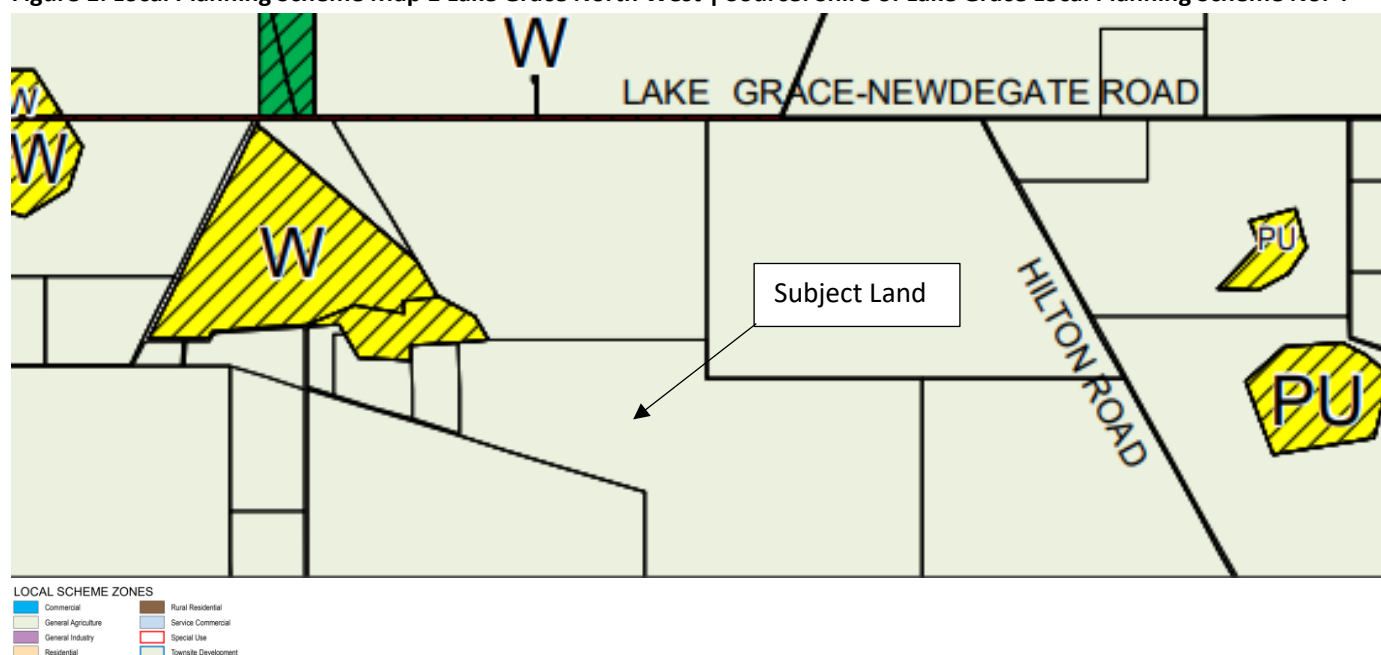



Figure 2: Map of Bushfire Prone Areas | Source: SLIP

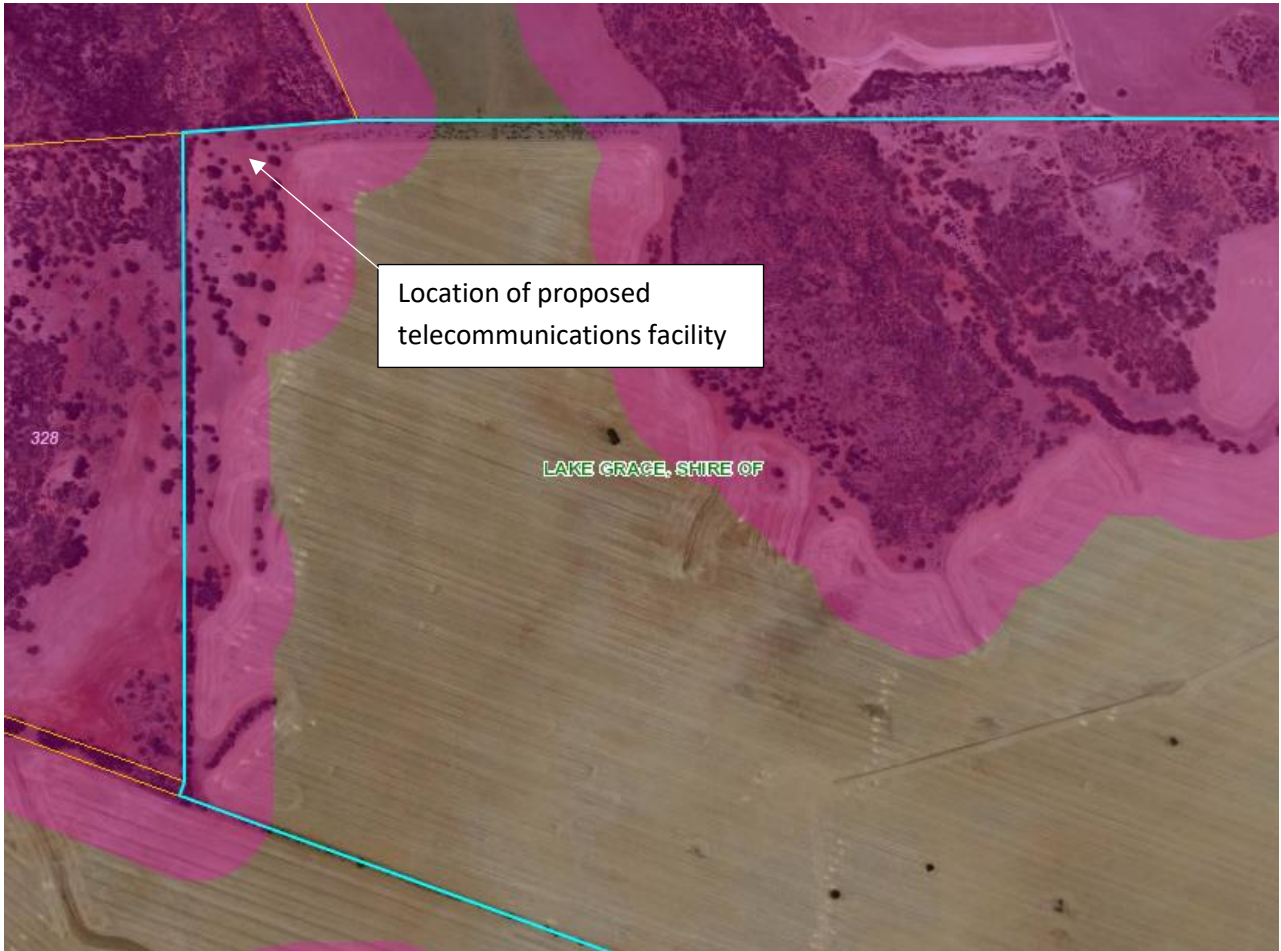

Figure 3: Native Vegetation Extent | Source: Natural Resource Information (WA)





The Proposal

It is proposed to establish a telecommunications tower and associated infrastructure on the subject land to provide wireless broadband network coverage to regional and remote areas of Western Australia.

Telecommunications infrastructure will consist of:

- A 45m metal tower as shown in **Attachment 6**;
- A combination of Dual Pole Parabolic Antennas (Dishes) and Sector Antennas as shown in **Attachment 7**;
- A control room cabinet will be located at the bottom of the tower as shown in Figure 4 below;
- Solar power system; and
- Fencing.

The new tower will be located in the north western corner of the subject land as shown on the Site Plan in **Attachment 5**. The tower and associated infrastructure will occupy an area of about 625m² including fencing.

The location is in an area just outside of the mapped remnant vegetation. There is no vegetation clearing required for the construction of the tower.

Access to the site will be via an existing crossover from Willcocks Road and an existing access track through the property as shown on the Site Plan. Access to the site by the applicant will be infrequent and will be required for initial construction and then approximately once a year for maintenance. It is expected that the maximum vehicle size visiting the site will be a medium rigid vehicle. It is not proposed to formalise parking given the infrequent access required to the facility.

Please refer to the attached Site Plan in **Attachment 5** showing the location of proposed infrastructure, access location and access pathway.

Please note that the proposed facility is for wireless broadband only and does not transmit electromagnetic waves/fields to mobile phones and therefore does not emit electromagnetic radiation.

Figure 4: Example of Proposed Telecommunications Facility and Control Room Cabinet





Figure 5: Proposed location of tower looking north west



Figure 6: Proposed location of tower looking south east





Planning Scheme and other Legislation

The Planning Scheme

The proposed use will be assessed against the Shire of Lake Grace Local Planning Scheme No. 4 (the Planning Scheme).

The Planning Scheme provides a definition for the proposed use as follows:

“telecommunications infrastructure” means premises used to accommodate the infrastructure used by or in connection with a telecommunications network including any line, equipment, apparatus, tower, antenna, tunnel, duct, hole, pit or other structure related to the network

The proposed telecommunications tower and associated infrastructure is consistent with the definition.

The subject land is located in the General Agriculture Zone and the Zoning Table in the Planning Scheme designates Telecommunications Infrastructure as D, a discretionary use requiring local government approval.

Section 64 of Schedule 2 Deemed provisions for local planning schemes of the *Planning and Development (Local Planning Schemes) Regulation 2015* requires advertising of complex applications for development approval. We note that the proposed telecommunications facility is not a complex application and therefore does not require advertising.

We have addressed the proposal against the objectives of the General Agriculture Zone under Part 3.2 of the Planning Scheme as follows:

- *To ensure the continuation of broad-acre farming as the principal land use in the District and encouraging where appropriate the retention and expansion of agricultural activities;*

Response: The proposed telecommunications facility does not affect the continuation of broad-acre farming on the subject land. The facility will be located outside of the usable cropping land on the property and will not interfere with farming processes.

- *to protect the potential of agricultural land for primary production and to preserve the landscape and character of the rural areas;*

Response: The proposed telecommunications facility will be located in an area outside of the cropping land on the property. The facility will be set back about 2km from Lake Grace-Newdegate Road and approximately 4km from Willcocks Road and it is unlikely the facility will be observed from the road or detract from the character of the rural area.

- *to provide for a range of rural pursuits such as broad-acre and diversified farming which are compatible with the capability of the land and retain the rural character and amenity of the locality;*

Response: The rural use of the property will be retained.

- *to control the fragmentation of broad-acre farming properties through the process of subdivision;*

Response: The proposed development will not fragment broad-acre farming and there is no subdivision as part of the proposal.

- *to consider non-rural uses where they can be shown to be of benefit to the District and not detrimental to the natural resources or the environment;*

Response: The proposed telecommunications facility will be located to be of benefit to the district by providing wireless broadband to a regional area.



- *to protect broad-acre agricultural land from land degradation and any further loss of biodiversity by:*
 - (i) *minimising the clearing of remnant vegetation on public and private lands;*
 - (ii) *encouraging the retention and protection of existing remnant vegetation;*
 - (iii) *encouraging the development and protection of corridors of native vegetation;*
 - (iv) *encouraging the development of environmentally acceptable surface and sub-surface drainage works;*
 - (v) *encouraging the rehabilitation of salt affected land;*
 - (vi) *controlling the introduction and spread of alien species of flora and fauna;*
 - (vii) *encouraging soil conservation through the application of cultural vegetational land management measures.*

Response: There is no vegetation clearing required for the proposed telecommunications facility. The facility will be located outside of the mapped remnant vegetation and will not interfere with native corridors.

We also address the relevant General Development Requirements under Part 4 of the Planning Scheme as follows:

- The minimum setback from all lot boundaries for any building on a lot classified as General Agriculture zone shall be 20 metres.

Response: The proposed telecommunications facility will be set back approximately 50m from the northern boundary and 80m from the western boundary.

- All proposals for development in the General Agriculture zone must have regard to both on-site and off-site impacts and, where deemed necessary by the local government, such proposals shall be accompanied by information identifying:
 - (a) environmental values and any environmental risks;
 - (b) the potential for land use conflict;
 - (c) the potential impacts and restrictions on approved uses on adjacent or nearby locations; and
 - (d) the separation distances and/or buffers relating to a potentially incompatible land use which need to be provided on-site

Response: There are very few on-site or off-site impacts as a result of the proposed telecommunications facility. The development generates very little traffic given the infrequent visits to the site. The facility uses line-of-site Microwave Tx technology delivering a wireless broadband network only and does not create emissions. Visual impacts will be minor given the 2km setback from Lake Grace-Newdegate Road, 4km setback from Willcocks Road and approximately 950m setback from the nearest sensitive receptor.

- No site shall be developed or building constructed to contain more than two storeys or exceed 10 metres in height measured to the highest proportion of the building from mean natural ground level, or such other ground level, as may be determined by the local government.

The local government may vary this requirement if it can be satisfied the development can comply with the development standards and: (a) Will not restrict light, sunshine and natural ventilation enjoyed by surrounding properties; (b) Will not intrude upon the privacy enjoyed by surrounding properties by virtue of overview; (c) Will not diminish views or outlook available from surrounding properties; and (d) Is sympathetic with the scale and character of the surrounding built environment.

Response: The proposed telecommunications tower is 45m high however the tower is unlikely to restrict light, sunshine or natural ventilation to surrounding properties given the remote location on the site.



- A person shall not develop or use any land or erect, use or adapt any building unless a suitable number of car parking spaces are provided in accordance with the requirements specified in Table 2.

Response: There is no particular number of parking spaces specified in Table 2 and it is not proposed to formalise parking given the infrequent access required to the facility.

State Planning Policy 5.2 – Telecommunications Infrastructure

The intent of State Planning Policy 5.2 – Telecommunications Infrastructure is to “balance the need for effective telecommunications services and effective roll-out of networks, with the community interest in protecting the visual character of local areas”.

As stated in the Policy, adequate and reliable telecommunications are essential for all aspects of contemporary community life, from supporting the State’s economy to creating and maintaining connected and cohesive social networks. Contact between emergency services and the community increasingly relies on the telecommunications networks. The importance of telecommunications services in Western Australia is recognised in the Western Australian Planning Commission’s (WAPC’s) State Planning Strategy 2050 (2014), which advocates for the provision of an effective state-wide telecommunications network. This network includes both above and below ground infrastructure to support both fixed line and wireless telecommunications.

The proposed development provides a wireless broadband network through line-of-site towers and complies with the intent of the Policy. Sites for telecommunications facilities are chosen for elevation, distance to other towers and ease of access. In this case, the facility is set well away from roads and sensitive receptors and is unlikely to affect visual amenity.

Therefore, the proposal is consistent with the principles set out in the Policy and can be balanced with the need for effective telecommunications services.

State Planning Policy 3.7 – Planning in Bushfire Prone Areas

Part of the subject land, and the location of the proposed telecommunications facility, has been identified in the SLIP mapping as being within a Bushfire Prone Area, as shown in Figure 2 above.

The intent of the SPP is “to implement effective, risk-based land use planning and development to preserve life and reduce the impact of bushfire on property and infrastructure”.

Sites for telecommunications facilities are chosen for elevation, distance to other towers and ease of access.

While the proposed facility is located in a bushfire prone area, the development does not result in an increase of residents or employees, nor does it increase the bushfire threat. Further, access is provided through areas that are not affected by the overlay mapping.

Accordingly, a bushfire assessment has not been carried out given the above.



Conclusion

The proposed development of a telecommunications facility will provide a much needed service to the local community. The location of the proposed tower is set well back from the road and will not impact on the privacy or visual amenity of the local residents.

The proposed location of the facility is outside of native vegetation mapping and does not require vegetation clearing.

The subject land is suitable for a telecommunications tower for the following reasons:

- The site has direct line of site to other proposed towers in the region;
- The site has good access and the development will not create a nuisance to traffic;
- The subject land is not flood prone;
- The development will not increase the threat of bushfire or put lives in danger;
- The proposed location has not been identified as containing native vegetation or Aboriginal artefacts;
- The proposed facility will not interfere with agricultural land; and
- Potential impacts are low.

Therefore, Council can be confident in approving the telecommunications facility as it will satisfy an essential community need.

We trust the details of the Development Application set out above and attached are satisfactory.

Thank you for your consideration and please do not hesitate to contact the writer if further information is required.

Yours Sincerely

Wendy Wood | Principal

SHIRE OF LAKE GRACE
LOCAL PLANNING SCHEME NO.4

APPLICATION FOR DEVELOPMENT APPROVAL



Owner Details – Attach a separate sheet where there are more than two landowners		
Name/s: Kim Charles Slarke, Michelle Jane Slarke		
ABN (if applicable):		
Address: PO Box 126, Lake Grace		
Postcode: 6353		
Phone: 0428 653 024 (work): (home): (mobile):	Fax:	E-mail: kms@esat.net.au
Contact person: Kim Slarke		
Signature: Please refer to attached consent		Date:
Signature:		Date:
NOTE: The signature of all registered owner(s) is required on all applications. This application will not proceed without the required signature/s. For the purposes of signing this application an owner includes the persons referred to in the Planning and Development (Local Planning Schemes) Regulations 2015 Schedule 2 clause 62(2).		
Applicant Details		
Name: Field Solutions Group c/- Out of the Woods Planning		
Address: 14 Cobbold Lane MAROOCHYDORE QLD		
Postcode: 4558		
Phone: (work): (home): (mobile): 0418 405 006	Fax:	E-mail: wendy@outofthewoodsplanning.com.au
Contact person for correspondence: Wendy Wood		
The information and plans provided with this application may be made available by the local government for public viewing in connection with the application. <input checked="" type="checkbox"/> Yes <input type="checkbox"/> No		
Signature: <i>W Wood</i>		Date: 8 October 2021

Property Details – Details must match those shown on the Certificate/s of Title		
Lot No: 13069	House/Street No:	Location No:
Diagram or Plan No: DP206385	Certificate of Title Volume No: 1843	Folio No: 327
Title encumbrances (e.g. easements, restrictive covenants): N/A		
Street name: Willcocks Road	Suburb: South Lake Grace	
Nearest street intersection: Cummings Road		
Proposed Development:		
Nature of development: <input type="checkbox"/> Works (New construction works with no change of land use) <input type="checkbox"/> Use (Change of use of land with no construction works) <input checked="" type="checkbox"/> Works and Use		
<i>NOTE: If the proposal involves advertising signage the Additional Information for Development Approval for Advertisements form must be completed and submitted with this application.</i>		
Is an exemption from development claimed for part of the development? <input type="checkbox"/> Yes <input checked="" type="checkbox"/> No		
If yes, is the exemption for: <input type="checkbox"/> Works <input type="checkbox"/> Use		
Description of proposed works and/or land use: Telecommunications Facility		
Description of exemption claimed (if relevant): N/A		
Nature of any existing buildings and/or land use: Cropping land		
Approximate cost of proposed development: \$145,000		
Estimated time of completion: 31/12/2021		
OFFICE USE ONLY		
Acceptance Officer's initials:		Date received:
Local government reference no:		



Development Application Checklist

Property Address Details:			
ITEM	INFORMATION REQUIREMENTS	APPLICANT USE ONLY <small>(Tick each accordingly)</small>	SHIRE USE ONLY <small>(Tick each accordingly)</small>
1	Completed <i>Application for Development Approval</i> form signed by the applicant as well as the landowner/s (Note: The signature/s of all landowners listed on the Certificate of Title for the subject land is compulsory).	x	
2	Plans prepared at a scale of not less than 1:500.	x	
3	Plans have a north point & show street name/s, lot boundaries & all lot boundary dimensions.	x	
4	Plans showing all existing natural ground levels and proposed new ground levels over the whole site including existing and proposed finished floor levels for all buildings, structures, parking areas, driveway/s and crossover/s.	x	
5	Plans showing the location, height, type, materials and finish of all existing structures on the land including boundary fences and retaining walls.	x	
6	Plans showing all buildings, structures and other improvements including vegetation proposed to be removed.	x	
7	Plans showing all buildings, structures and other improvements proposed to be constructed, modified or upgraded including their areas, dimensions, external surface materials/finishes and colours (including suitably scaled elevation drawings).	x	
8	Plans showing all existing and proposed means of access for pedestrians and vehicles to and from the site including pathways, crossovers and driveways and their surface treatments.	x	
9	Plans showing the location, number, dimensions and layout of all existing and/or proposed on-site car parking bays.	N/A	
10	Plans showing the location and dimensions of any	N/A	



Development Application Checklist

	area/s proposed to be provided for the loading and unloading of vehicles carrying goods or commodities to and from the site and the means of access to and from those areas.		
11	Plans showing the location, dimensions and surface treatments for any existing or proposed open storage or trade display area/s.	N/A	
12	Plans showing the location of all existing infrastructure and street trees in the road verge area immediately abutting the site.	N/A	
13	Plans showing all new landscaping proposed to be installed (including details of plant species) and any existing landscaping proposed to be retained (i.e. grouped dwellings, commercial & industrial developments only).	N/A	
14	A pre-calculation plan is provided for all grouped dwelling development proposals (i.e. a suitably scaled plan shows areas & dimensions for all proposed new strata lots).	N/A	
15	Plan/s showing the location and extent of any proposed overshadowing on adjoining properties (residential development proposals only).	N/A	
16	For all proposed new advertising signs, a completed and signed <i>Additional Information for Development Approval for Advertisements</i> form as well as plans showing the location, dimensions, external surface materials/finishes and colours for all existing and proposed new advertising signage.	N/A	
17	A completed Bushfire Attack Level (BAL) assessment prepared by an accredited Level 1 BAL Assessor or Bushfire Planning Practitioner, unless otherwise exempted in the <i>Guidelines for Planning in Bushfire Prone Areas</i> (WAPC 2015, as amended).	N/A	

SHIRE OF LAKE GRACE
LOCAL PLANNING SCHEME NO.4



**ADDITIONAL INFORMATION FOR
DEVELOPMENT APPROVAL FOR ADVERTISEMENTS**

Note: To be completed in addition to the Application for Development Approval form.

1. Description of property on which advertisement is to be displayed including full details of its proposed position within that property:

2. Details of proposed sign:

(a) Type of structure on which advertisement is to be erected (i.e. freestanding, wall mounted, other):

(b) Height: Width: Depth:

(c) Colours to be used:

(d) Height above ground level —
 (a) (to top of advertisement):
 (b) (to underside):

(e) Materials to be used:

Illuminated: Yes / No

If yes, state whether steady, moving, flashing, alternating, digital, animated or scintillating and state intensity of light source:

3. Period of time for which advertisement is required:

4. Details of signs (if any) to be removed if this application is approved:

Note: *This application should be supported by a photograph or photographs of the premises showing superimposed thereon the proposed position for the advertisement and those advertisements to be removed detailed in 4 above.*

Signature/s of advertiser(s):
(if different from landowners)

Date:

We, Kim Charles Slarke and Michelle Jane Slarke, being the registered landowners of the premises identified as Lot 13069 on DP206385 (via Lake Grace-Newdegate Road, South Lake Grace), consent to the making of an application for development approval by Field Solutions Group c/- Out of the Woods Planning on the premises described above for the purpose of a Telecommunications Tower and associated infrastructure.



.....
Kim Charles Slarke

25/8/21

.....
Date



.....
Michelle Jane Slarke

25/08/2021

.....
Date

WESTERN



AUSTRALIA

REGISTER NUMBER 13069/DP206385	
DUPLICATE EDITION 2	DATE DUPLICATE ISSUED 7/2/2018

RECORD OF CERTIFICATE OF TITLE
UNDER THE TRANSFER OF LAND ACT 1893

VOLUME 1843 FOLIO 327

The person described in the first schedule is the registered proprietor of an estate in fee simple in the land described below subject to the reservations, conditions and depth limit contained in the original grant (if a grant issued) and to the limitations, interests, encumbrances and notifications shown in the second schedule.

BGRoberts
REGISTRAR OF TITLES



LAND DESCRIPTION:

LOT 13069 ON DEPOSITED PLAN 206385

REGISTERED PROPRIETOR:
(FIRST SCHEDULE)

KIM CHARLES SLARKE
MICHELLE JANE SLARKE
BOTH OF POST OFFICE BOX 126, LAKE GRACE
AS JOINT TENANTS

(T I358672) REGISTERED 20/1/2003

LIMITATIONS, INTERESTS, ENCUMBRANCES AND NOTIFICATIONS:
(SECOND SCHEDULE)

1. N825273 MORTGAGE TO RURAL BANK LTD REGISTERED 7/2/2018.

Warning: A current search of the sketch of the land should be obtained where detail of position, dimensions or area of the lot is required.
* Any entries preceded by an asterisk may not appear on the current edition of the duplicate certificate of title.
Lot as described in the land description may be a lot or location.

-----END OF CERTIFICATE OF TITLE-----

STATEMENTS:

The statements set out below are not intended to be nor should they be relied on as substitutes for inspection of the land and the relevant documents or for local government, legal, surveying or other professional advice.

SKETCH OF LAND: 1843-327 (13069/DP206385)
PREVIOUS TITLE: 1843-327
PROPERTY STREET ADDRESS: NO STREET ADDRESS INFORMATION AVAILABLE.
LOCAL GOVERNMENT AUTHORITY: SHIRE OF LAKE GRACE

WILLIAMS LOC'S 13069, 14409, 14930, 15049 & 15058

CORR: 3405/53, 3737/52, 1919/51, 1309/53 & 2006/53

DIMENSIONS IN METRES

WMS9529
DIA. 410/3

ROE 600
DIA. 457/8

LOC'S	CHANGE CORE N	ANGLE E	ANGLE CODE	AREA
13069	13.7	+5	-30°	2526.27534

WMS 9529
DIA 41013

WMS 13132
DIA 47798

WMS 12487
DIA 46235

WMS 15057
O.P. 6334

WMS LOC
15463
O.P. 5985

WMS 15024
O.P. 6314

WMS 15016
O.P. 6381

WILLIAMS
14930
528 a.o.r. 17p.
213-7170 ha

WILLIAMS
15049
1316 a.o.r. 25p.
532-6225 ha

WILLIAMS
14409
1578 a.o.r. 35p.
638-8848 ha

WMS 13237
DIA 1006

ROAD
ROAD
ROAD

C.G.

C.G.

C.G.

WMS 15174
117 a.o.r. 10p
97-344 ha

WILLCOCKS 800

180° 10'

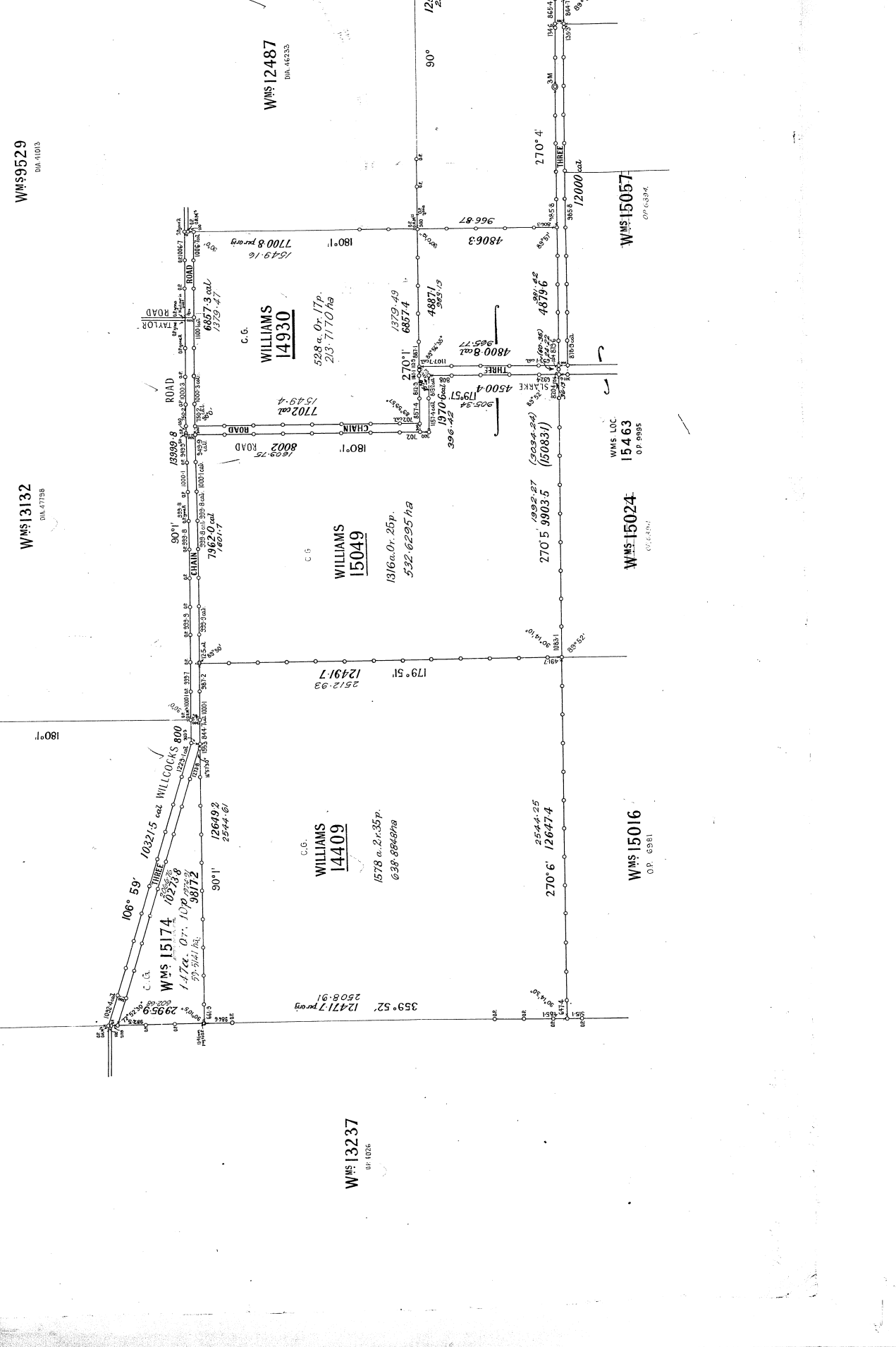

WILLIAMS LOC'S 13069, 14409, 14930, 15049 & 15058
 CORR: 3405/63, 3337/62, 1009/51, 8009/53 & 2006/53

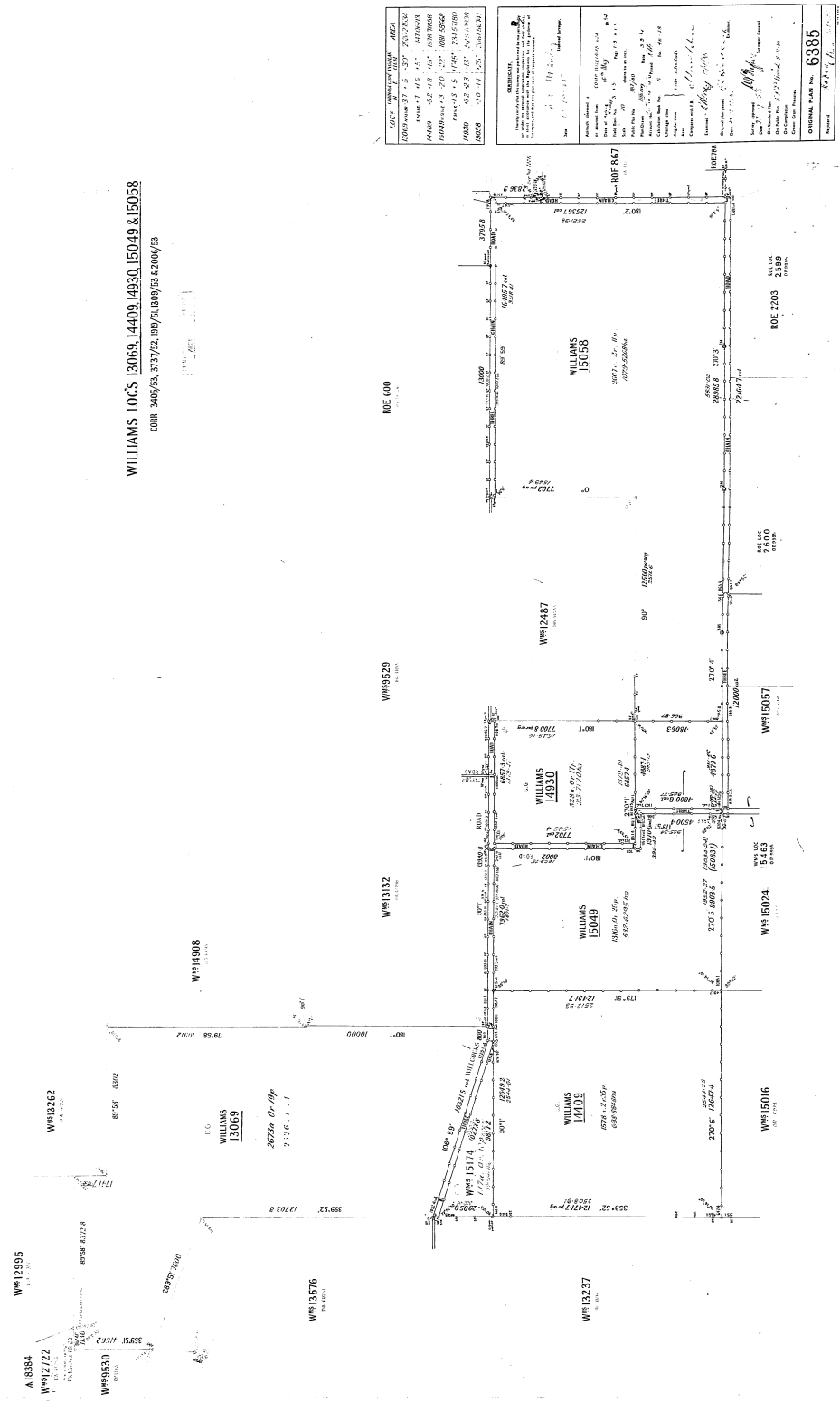

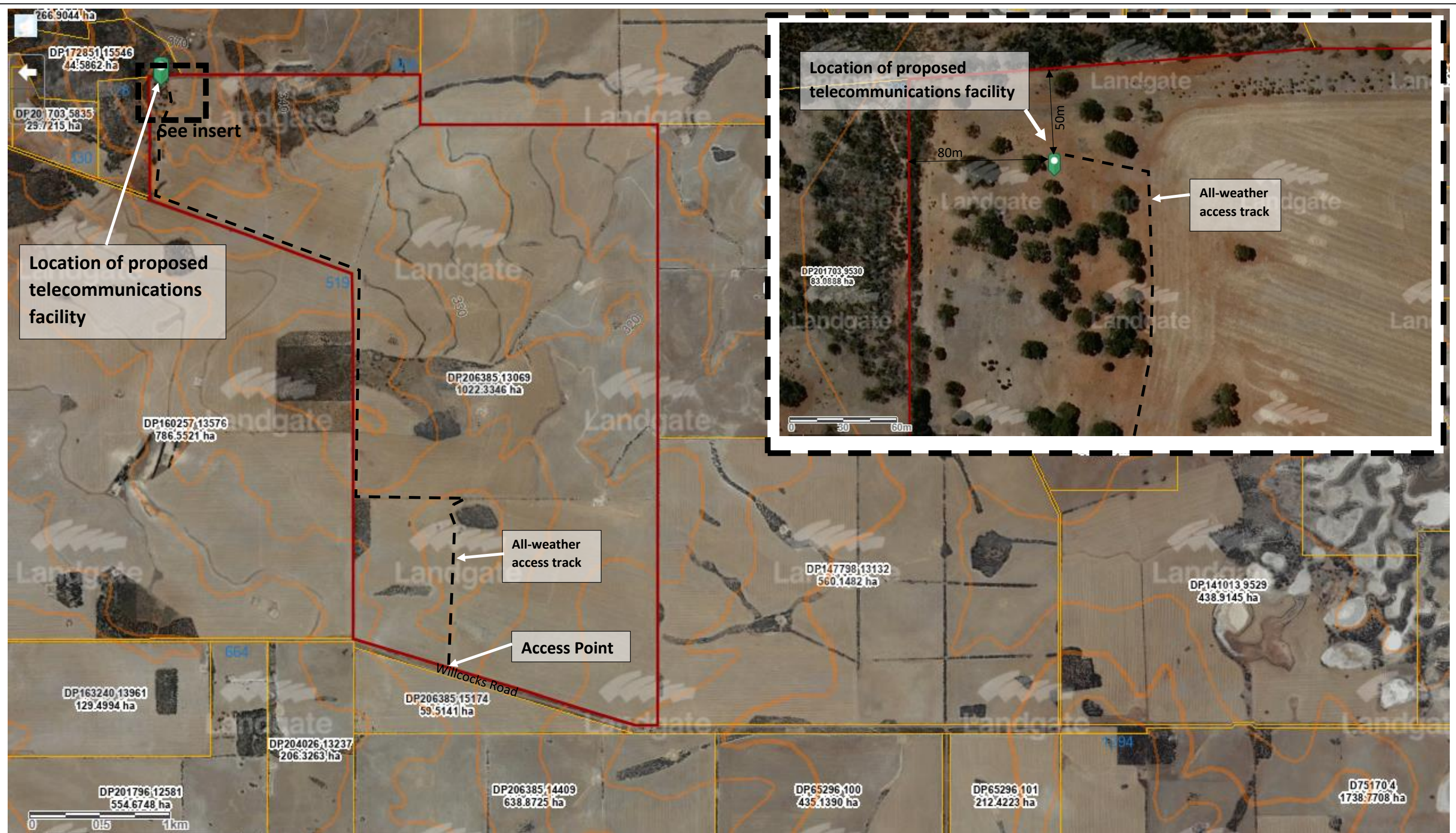

Source: Landgate

ABN 26 373 259 082
 14 Cobbold Lane
 MAROOCHYDORE QLD 4558
 0418 405 006

OUT OF THE WOODS
PLANNING

SITE PLAN

Lake Grace Telecommunications Facility
 Lot 13069 on DP206385
 Willcocks Road, South Lake Grace

Drawing No. 067-WA003 Issue C

Date 08/10/2021

FIELD solutions rural regional remote
 TELECOMMUNICATIONS + SOFTWARE + CLOUD

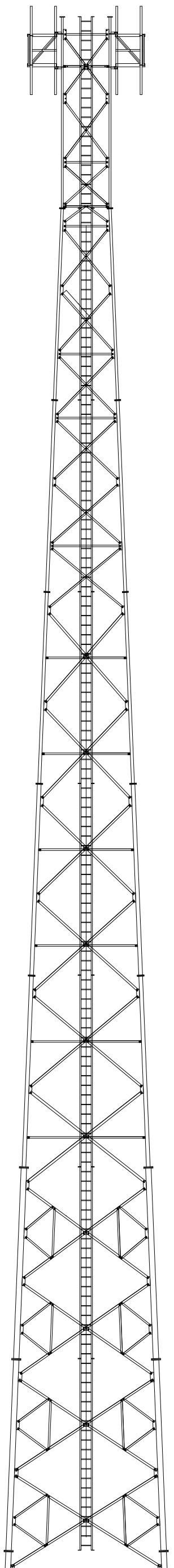

TOWER ELEVATION

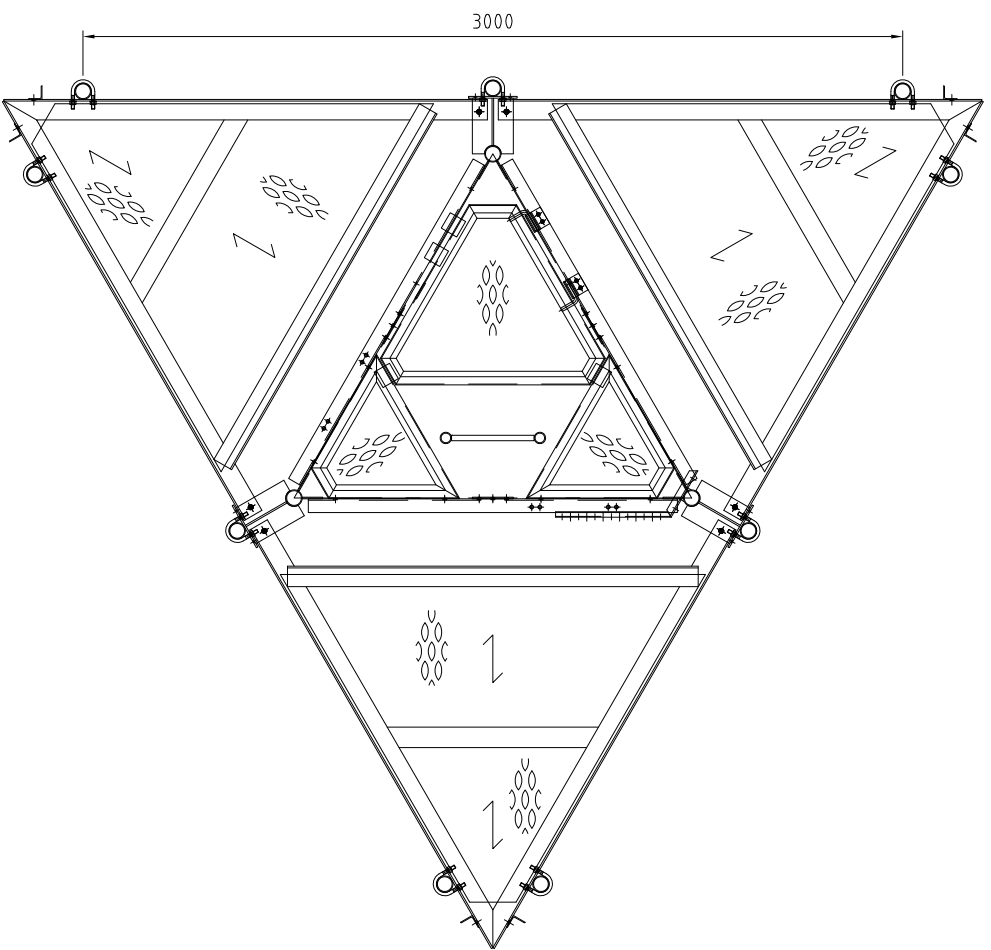

PLAN VIEW OF HEADFRAME

NOT FOR CONSTRUCTION

<p>ROAM PTY LTD 8 MEKA STREET MALAGA W.A. 6090 AUSTRALIA TEL (618) 9248 4950 FAX (618) 9248 4951</p>		<p>DESIGN: C.C</p>	<p>DATE:</p>	<p>SAMPLE DRAWING 4.5m RT4.0 GENERAL ARRANGEMENT</p>		<p>SCALE: (A3) N.T.S</p>	<p>DWG. No. R05341-1-2</p>	<p>VER. -</p>	<p>REV. A</p>
<p>REFERENCE DRAWINGS</p>	<p>REF</p>	<p>REVISION</p>	<p>BY</p>	<p>DATE</p>	<p>THIS DRAWING PRODUCED BY ROAM IS NOT SOLD BUT LENT. ITS CONTENTS MUST NOT BE COPIED, TRACED OR COMMUNICATED TO ANY PERSON WHATSOEVER WITHOUT WRITTEN CONSENT OF ROAM PTY. LTD.</p>				
<p>A</p>	<p>ISSUED FOR REVIEW</p>	<p>M.W</p>	<p>16-5-18</p>	<p>M.W</p>	<p>16-5-18</p>	<p>M.W</p>	<p>16-5-18</p>	<p>-</p>	<p>A</p>

ePMP™ 3000 Sector Antenna



Cambium Networks has deployed more than five million radios around the world achieving unparalleled degrees of scalability. Continuing the tradition of designing and manufacturing industry leading antenna solutions, the ePMP 3000 4X4 sector antenna encompasses all the key differentiations of the Cambium Antenna line and adds 4X4 Multi User MIMO Capability. Designed to work in 5 GHz spectrum and 90 degree coverage, the antenna is an integral part of the ePMP 3000 Access Point and allows for Multi User MIMO Operation.

KEY DEPLOYMENT ADVANTAGES

- **Frequency Re-use:** Designed for ABAB channel re-use (two channels covering four sectors), the sector antenna has a minimum 30 dB front to back ratio over a wide rear facing aperture.
- **Channel Flexibility:** Consistent gain from 4.9 to 6.0 GHz allows the operator to select a channel anywhere in the band and achieve the expected performance.
- **Consistent Coverage:** Excellent null fill capabilities of the antenna allow for broad geographical coverage within a sector even near the base of the tower and the edges of the sector.
- **Designed for the Installer:** Small, compact design, integrated ePMP radio mount and GPS antenna integration.
- **Predictable Performance:** The sector antenna is integrated into Cambium Networks LINKPlanner. The 3D model shows coverage at all elevations and across the azimuth.

KEY SPECIFICATIONS:

- 17 dBi gain
- 4.9 to 5.97 GHz spectrum
- 30 dBi front to back ratio
- IP 65 ruggedization

SPECIFICATIONS

ePMP 3000 SECTOR ANTENNA

Model Number	C050910D301A
Frequency Range	4.9 GHz to 5.97 GHz
Gain	17 dBi
3 dB Beamwidth - Azimuth	70 degrees
3 dB Beamwidth - Elevation	6 degrees
Electrical Downtilt	-2 degrees
Polarization	2X Horizontal, 2X Vertical

SPECIFICATIONS

ePMP 3000 SECTOR ANTENNA

Model Number	C050910D301A
Port-to-Port Isolation	> 20 dB
Front-to-Back Ratio	30 dB
Maximum Input Power	5 W
Input Impedance	50 ohms
Mounting Connectors	4 x RP SMA
Mounting Hardware	Included for mounting to mast diameters 2" to 4" (5 cm to 10 cm) -10 to +5 degree tilt Hardware included to connect ePMP access point to back of antenna body
Physical Dimensions	Antenna Body: 23.4" (H) x 9.6" (W) x 3.25" (D) (594 mm x 157 mm x 110 mm)
Weight	Antenna Body: 8.0 lbs, 3.7 kg w/ ePMP 3000 Access Point and Mounting Brackets: 13.8 lbs, 6.3 kg
Environmental	IP65
Radome Material	UV Protected ABS
Operating Temp	-40°C to 60°C (-40°F to 140°F)

ANTENNA PATTERNS

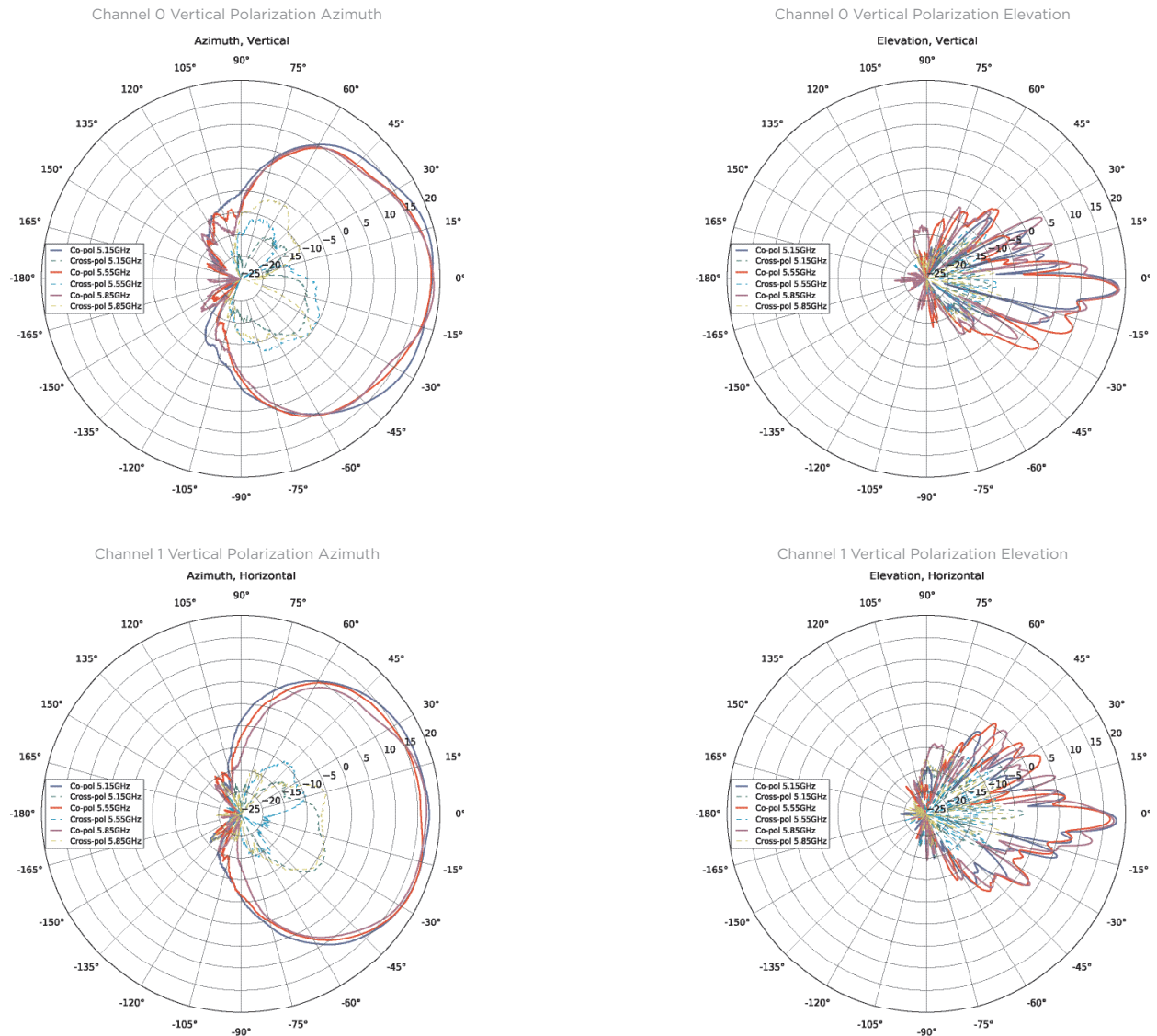

ANTENNA PATTERNS

Channel 2 Vertical Polarization Azimuth

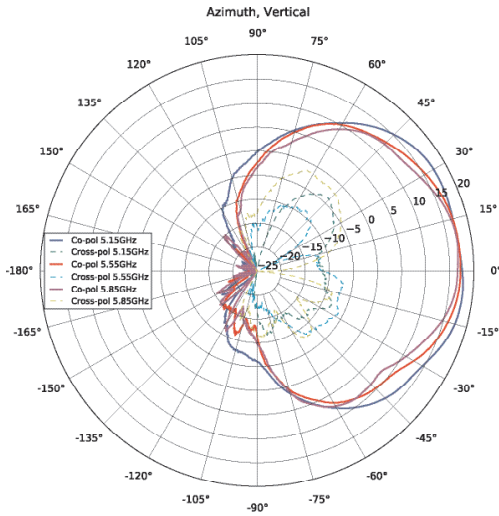

Channel 2 Vertical Polarization Elevation

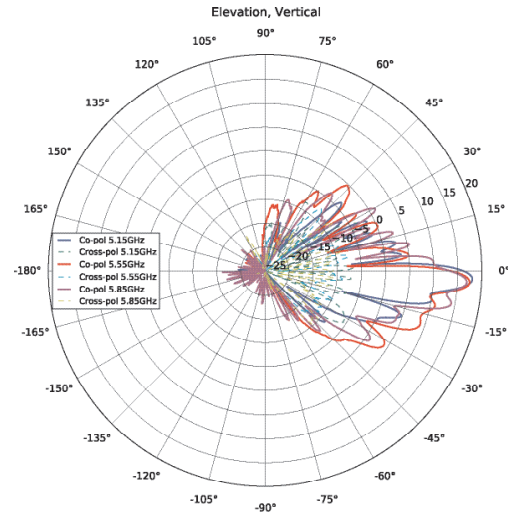

Channel 3 Vertical Polarization Azimuth

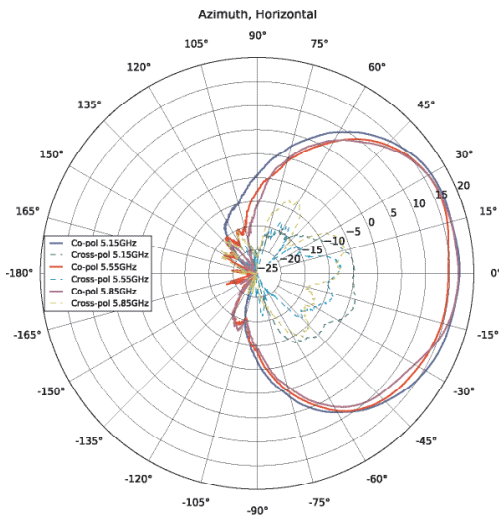

Channel 3 Vertical Polarization Elevation

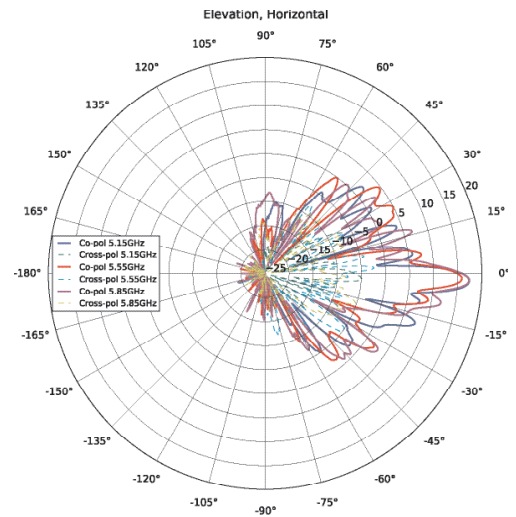



5.25 - 5.85 GHz High Performance Dual Pole Parabolic Reflector Antenna

High Performance Dual Pole Parabolic Reflector Antennas from Cambium Networks are well-suited for deployment with any of the sub-6 GHz PTP products. They are engineered to provide ETSI class 2/3 radiation pattern performance as well as excellent gain. Field-proven preassembled antennas and robust pole mounts ensure “set and forget” installation with minimal post installation maintenance. The included radome ensures robust and reliable performance under the most challenging conditions.

FEATURES AND BENEFITS:

- High Performance ETSI Class 2/3* Parabolic Antennas - Excellent performance for a wide range of applications
- Fully Preassembled at the Factory - Simplifies installation on site and guarantees “factory tested” quality
- Industry leading 7year warranty
- Suitable for deployment with PTP 650, PTP 670, PTP 700 and PTP 450i connectorized radios.
- Fully supported in LINKPlanner™ providing accurate predictions of PTP link performance and availability. LINKPlanner™ is available at no charge from the support website at cambiumnetworks.com.

**ETSI Class depends on frequency band*



SPECIFICATIONS

GENERAL

Antenna Type	High Performance Parabolic Reflector Antenna
Size, nominal	2 ft (0.6 m); 3 ft (0.9 m); 4 ft (1.2 m)
Polarization	Dual
Standard RF Connector Type	N-Female

SPECIFICATIONS

ELECTRICAL	2 FT (0.6 M)	3 FT (0.9 M)	4 FT (1.2 M)
Model Number	RDH4508B	RDH4509B	RDH4510B
Description	5.25-5.85 GHZ, 2-FT (0.6M), HIGH PERFORMANCE DUAL-POL	5.25-5.85 GHZ, 3-FT (0.9M), HIGH PERFORMANCE DUAL-POL	5.25-5.85 GHZ, 4-FT (1.2M), HIGH PERFORMANCE DUAL-POL
Operating Frequency Band	5.25 - 5.85 GHz	5.25 - 5.85 GHz	5.25 - 5.85 GHz
Half Power Beamwidth, Horizontal	6.1 degrees	4.2 degrees	3 degrees
Half Power Beamwidth, Vertical	6.1 degrees	4.2 degrees	3 degrees
Cross-Polarization Discrimination	28 dB	30 dB	30 dB
Front to Back Ratio (F/B)	44 dB	46 dB	49 dB
Gain, Low Frequency	28.3 dB	31.8 dB	34.2 dBi
Gain, Mid Frequency	28.8 dB	32.3 dBi	34.7 dBi
Gain, High Frequency	29.3 dB	32.8 dBi	34.7 dBi
VSWR	1.5:1	1.5:1	1.5:1
Return Loss	-14 dB	-14 dB	-14 dB

MECHANICAL	2 FT (0.6 M)	3 FT (0.9 M)	4 FT (1.2 M)
Model Number	RDH4508B	RDH4509B	RDH4510B
Description	5.25-5.85 GHZ, 2-FT (0.6M), HIGH PERFORMANCE DUAL-POL	5.25-5.85 GHZ, 3-FT (0.9M), HIGH PERFORMANCE DUAL-POL	5.25-5.85 GHZ, 4-FT (1.2M), HIGH PERFORMANCE DUAL-POL
Fine Azimuth Adjustment	+/- 10 degrees	+/- 10 degrees	+/- 10 degrees
Fine Elevation Adjustment	+/- 30 degrees	+/- 25 degrees	+/- 25 degrees
Mounting Pipe Diameter, Min	2 inch 5.08 cm	4.5 inch 11.4 cm	4.5 inch 11.4 cm
Mounting Pipe Diameter, Max	4.5 inch 11.4 cm	4.5 inch 11.4 cm	4.5 inch 11.4 cm
Net Weight	27 lbs 12.3 kg	50 lbs 12.3 kg	85 lbs 38.3 kg
Wind Velocity Operational	90 mph 145 km/h	90 mph 145 km/h	90 mph 145 km/h
Wind Velocity Survival Rating	125 mph 201 km/h	125 mph 201 km/h	125 mph 201 km/h
Axial Force (FA)	202 lbs 899 N	403 lbs 1972 N	737 lbs 3278 N
Side Force (FS)	100 lbs 445 N	200 lbs 890 N	365 lbs 1623 N
Twisting Moment (MT)	194 ft-lbs 263 Nm	344 ft-lbs 466 Nm	784 ft-lbs 1063 Nm
Operating Temperature Range	-40 to +60 C	-40 to +60 C	-40 to +60 C
Max Pressure, PSIG, (if waveguide interface)	5	5	5

REGULATORY COMPLIANCE

RoHS-compliant	Yes	Yes	Yes
----------------	-----	-----	-----

SHIPPING INFORMATION	2 FT (0.6 M)	3 FT (0.9 M)	4 FT (1.2 M)
Model Number	RDH4508B	RDH4509B	RDH4510B
Description	5.25-5.85 GHZ, 2-FT (0.6M), HIGH PERFORMANCE DUAL-POL	5.25-5.85 GHZ, 3-FT (0.9M), HIGH PERFORMANCE DUAL-POL	5.25-5.85 GHZ, 4-FT (1.2M), HIGH PERFORMANCE DUAL-POL
Package Type	Cardboard	Wood Crate	Wood Crate
Gross Weight	48 lbs 28.7 kg	143 lbs 69.8 kg	196 lbs 88.9 kg
Dimensions, L x W x H	31 x 31 x 25in 79 x 79 x 64 cm	47 x 28 x 48in 119 x 71 x 122 cm	59 x 35 x 60in 180 x 89 x 152 cm
Shipping Volume	13.9 cu ft 0.39 cu m	36.56 cu ft 1.04 cu m	71.7 cu ft 2.03 cu m

TECHNICAL DRAWINGS

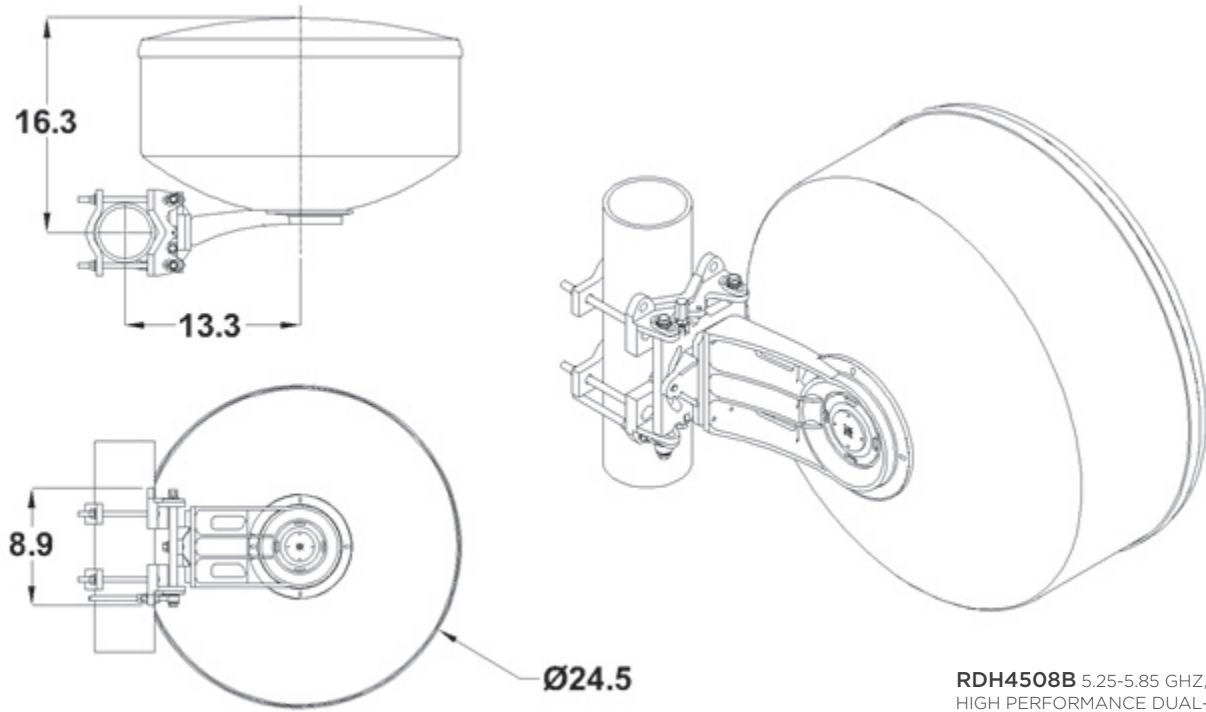

RDH4508B 5.25-5.85 GHZ, 2-FT (0.6M),
HIGH PERFORMANCE DUAL-POL

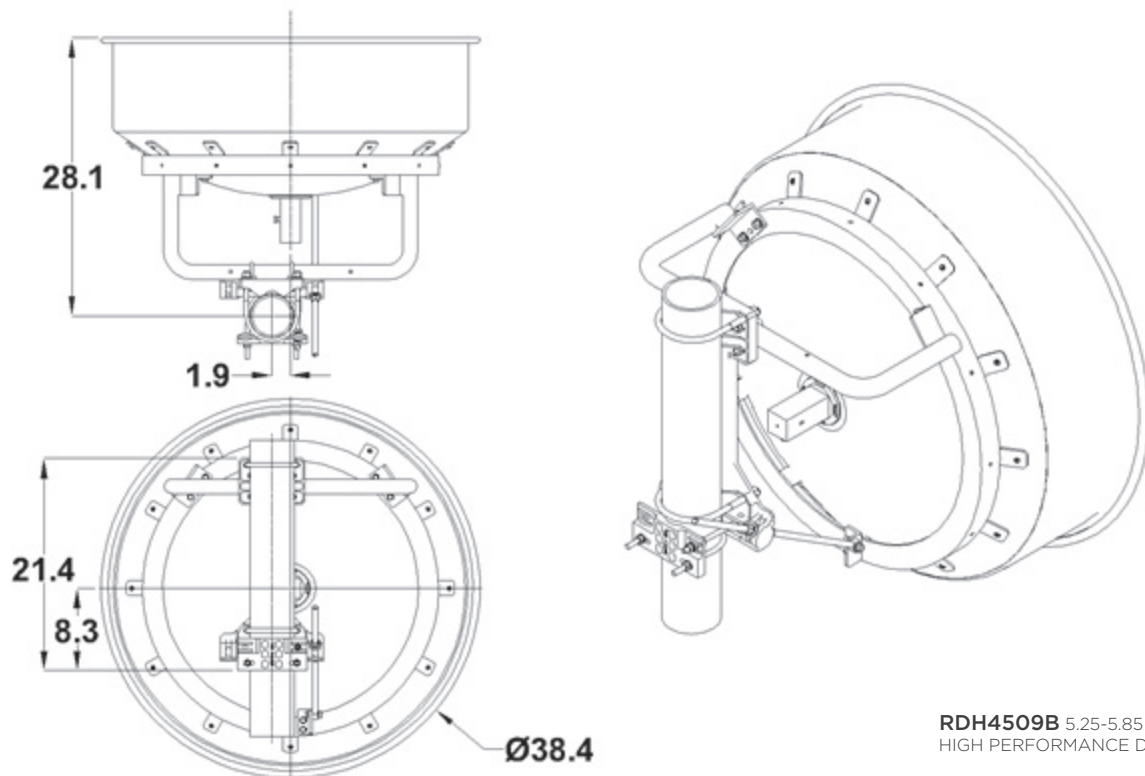

RDH4509B 5.25-5.85 GHZ, 3-FT (0.9M),
HIGH PERFORMANCE DUAL-POL

TECHNICAL DRAWINGS

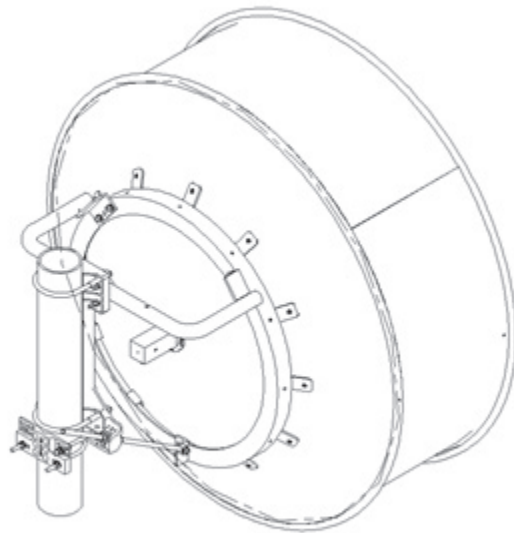
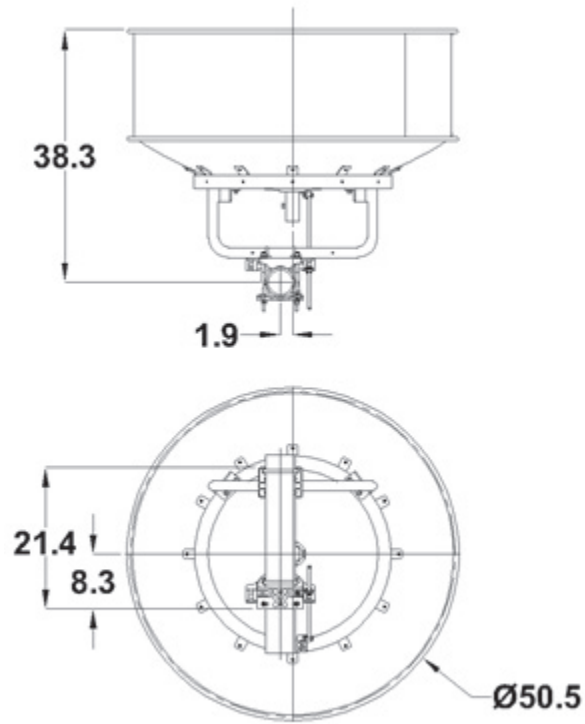

RDH4510B 5.25-5.85 GHz, 4-FT (1.2M),
HIGH PERFORMANCE DUAL-POL

TECHNICAL SPECIFICATIONS

	PTP 820S	PTP 820C + PTP 820C HP	PTP 820G	PTP 820F	PTP 820E	PTP 850E
Supported Frequency	6 - 38 GHz	6 - 38 GHz	6 - 38 GHz	6-38, 71-76, 81-86 GHz	71-76, 81-86 GHz	71-76, 81-86 GHz
Role in the Network	Compact all outdoor	Compact all outdoor w/ multi-core	Split Mount or all indoor, multi-carrier options	Split mount or all-indoor, multi-carrier options	Multiband with PTP 820C/S	Multiband with PTP 820C/S
Transport Technology	All packet	All packet	Hybrid and/or all packet	Hybrid and/or all packet	All packet	All packet
TDM Interface	None	None	16 x E1/T1	16 x E1/T1	None	None
Modulation	QPSK to 2048 QAM w/ACM	QPSK to 2048 QAM w/ACM	QPSK to 2048 QAM w/ACM	QPSK to 4096 QAM w/ACM	BPSK to 1024 QAM w/ACM	BPSK to 512 QAM w/ACM
Channel Size	3.5 to 80 MHz	3.5 to 80 MHz	3.5 to 60 MHz	6-38 GHz 14 to 112 MHz, 71-86 GHz: 62.5 to 500 MHz	62.5 - 500 MHz	250 MHz to 2 GHz
Capacity (Layer 2)	679 Mbps	1.36 Gbps	527 Mbps, 1.05 Gbps	542 Mbps, 1.08 Gbps	2.4 Gbps	10 Gbps
Capacity with Multi-Layer Compression	833 Mbps	1.67 Gbps	833 Mbps (1+0) 1.67 Gbps (2+0)	1.69 Gbps (1+0) 3.2 Gbps (2+0)	2.4 Gbps (1+0) 4.8 Gbps (2+0)	10 Gbps (1+0) 20 Gbps (2+0)
Configuration	1+0, 1+1 HSB, 2+0	1+0 to 4+0, 1+1/2+2 HSB, E/W, 1+0 SD, 2+2 SD	1+0, 1+1 HSB, 2+0 (E/W), 2+0 XPIC, 2+0 MC-ABC	1+0, 3 x 1+0, 2 x 2+0, 2 x 2+0 + 1+0, 1+1 HSB*, 2+2 HSB*	1+0, 2+0	1+0, 2+0 (XPIC)
LOS MIMO	No	Yes, 4x4 or 2x2	No	No	No	No
XPIC	No	Yes	Yes	Yes	No	Yes
Ethernet Interface	1 x 10/100/1000Base-T and 2x1000base-X or 10/100/1000Base-T	1 x 10/100/1000Base-T and 1x1000base-X or 10/100/1000Base-T	4 x 10/100/1000Base-T and 2x1000base-X	4x1 Gbe (RJ-45/SFP) 1x 2.5/1 Gbps SFP	1x 10/100/1000Base-T, PoE 1x 1Gbps SFP cage Optional: 1 x10/100/100 Base-T or 10 Gbps SFP cage	1x 2.5/1 Gbps SFP 1x 10 Gbps SFP 10 GE (SFP+) Optional: QSFP(4x10 GE or 1x40) or SFP+ (1x10 GE)
Management Interface	1 x 10/100 Base-T	1 x 10/100 Base-T	1 x 10/100 Base-T	1 x 10/100 Base-T	1 x10/100/100 Base-T for management	1 x 1 GE RJ-45 for management
External Alarm	None	None	1 x DB9	1 x DB9	None	None
Dimensions (HxWxD - mm)	230 x 233 x 98	PTP 820C: 230x233x98 PTP 820C HP: 315x284x107	IDU: 44x426x180 RFU-C: 200x200x85 RFU-A: 44x443x421	IDU: 44x482x165 RFU-D: 230x233x98 RFU-D-HP: 319x286x107 RFU-S: 217x210x85 RFU-E: 220x198x75	220x198x75 43 dBi integrated antenna: 280x280x110	322x227x86 43 dBi integrated antenna: 341x270x103
Environmental	-33°C to +55°C (-45°C to +60°C extended)	-33°C to +55°C (-45°C to +60°C extended)	IDU: -5°C to +55°C (-25°C to +65°C extended) RFU-C: -33°C to +55°C (-45°C to +60°C extended) RFU-A: -5°C to +55°C (-25°C to +65°C extended)	IDU: -5°C to +55°C (-15°C to +60°C extended); RFU: -33°C to +55°C (-45°C to +60°C extended)	-33°C to +55°C (-45°C to +60°C extended)	-33°C to +55°C (-45°C to +60°C extended)
Power Input	-48 VDC	-48 VDC	-48 VDC	-48 VDC	-48 VDC	-48 VDC
PoE Injector Power Input	-48 VDC or +24 VDC	PTP 820C ONLY: -48VDC or +24VDC	N/A	N/A	-48 VDC or +24 VDC	-48 VDC or +24 VDC
Maximum Power Consumption	6-11 GHz: 40W; 13-38 GHz: 35W	Multi-Core Operation: PTP 820C: 6 GHz: 65W; 7 GHz: 75W; 11 GHz: 65W; 13-15 GHz: 55W; 18-24 GHz: 48W; 26-38 GHz: 55W PTP 820C HP: 135W	IDU Eth-only with single modem: 23.5W, addition for second modem, 2.9W, additional for 16 E1/DS1: 11W • RFU-C: 6-26 GHz; 1+0 22W; 1+1 39W; 28-38 GHz, 1+0 26W; 1+1 43W RFU-Ae / RFU-Aep • 1+0 High Level: 77W / 90W Medium Level: 53W / 73W Low Level: 43W / 47W Mute: 24W / 24W • 1+1 HSB/SD BBS: High Level: 101W / 114W Medium Level: 77W / 97W Low Level: 67W / 71W Mute: 48W / 48W	IDU: 48W maximum RFU-D: 75W RFU-D-HP: 130W/180W RFU-S: 43W RFU-E: 43W	43W Active 35W Standby	58W Active 47W Standby

US Headquarters

3800 Golf Road, Suite 360.
Rolling Meadows, IL 60008 USA
+1 888 863 5250

San Jose Office

2010 N. 1st Street, Suite 400
San Jose, CA 95131 USA

Thousand Oaks Office

2101 Corporate Center Dr # A
Newbury Park, CA 91320 USA

India Office

Cambium Networks Consulting Private Ltd
5th Floor, Quadrant 1, Umiya Business Bay, Tower 2,
Outer Ring Road,
Kadubisenahalli, Varthur Hobli Road, Bangalore East
Taluk, Bangalore- 560037
+91 80 67333100

UK Office

Unit B2, Linhay Business Park,
Eastern Road, Ashburton, United Kingdom, TQ13 7UP
+44 1364 655500

Copyright © 2019 Cambium Networks, Ltd.



PTP 820/850
LICENSED ETHERNET MICROWAVE FOR MULTI-SERVICE NETWORKS

Cambium PTP 820/850



A single platform serving all radio transport requirements.

PTP 820/850 is a point-to-point licensed microwave backhaul platform that integrates leading networking functionality with the industry's most advanced microwave technologies, creating a superior microwave transport solution.

Supporting licensed frequency bands ranging from 6 to 86 GHz, the PTP 820/850 series delivers a wide range of configurations to offer a tailored solution for any deployment scenario.

Composed of high-density multi-technology nodes and integrated radio units, the PTP 820/850 series offers flexibility in choosing all-indoor, split-mount, and all-outdoor configuration options. Exploiting unique Line of Sight (LOS) Multiple Input Multiple Output (MIMO) technology, modulation up to 4096 QAM and wider channel bandwidths ensures industry-leading throughput and spectral efficiency.

The PTP 820E/850E operate in E-Band radio providing throughput up to 20Gbps, this eliminates the need for future forklift upgrades, or major system overhaul by the network operator to deliver multi gigabit-plus capacity.

PTP 820/850 also offers both Synchronous Ethernet (SyncE) and IEEEv2 synchronization protocols required for large ISP and MPLS networks.

Operations, Administration and Maintenance (OA&M) tools coupled with a full suite of network and element management systems (NMS and EMS) simplify network provisioning and monitoring, reducing operators' total cost of ownership and enabling them to meet the most stringent service level agreements.

Combining technologies, equipment and services, PTP 820/850 enables network operators to meet accelerating demand for capacity cost-effectively under rapidly evolving conditions.

PTP 820/850 Product Series Highlights

- Licensed frequency bands 6-86 GHz
- Up to 4096 QAM, with 12-step hitless and errorless Adaptive Coding & Modulation (ACM) for high reliability
- Up to 20 Gbps bandwidth supported
- Multi-gigabit radio capacity with high spectral efficiency
- TDM and/or packet supporting legacy services and evolution to all-packet
- Integrated Ethernet Switch, MEF Carrier Ethernet 2.0 compliant, MPLS-TP-ready
- Header de-duplication for additional capacity boost
- Intelligent service-centric management utilizing QoS and advanced OA&M capabilities
- Carrier-grade service resiliency (G.8032, MSTP)
- ITU-T Y.1731 Performance Management – MEF 35
- Integrated synchronization solution: Native/SyncE/IEEE 1588v2
- Lowest power consumption with adaptive green mode
- Low latency with unique frame cut through for latency sensitive services
- Industry-leading system gain

NOTES: The highlight feature may not apply to all PTP 820/850 platform.



PUBLIC SAFETY



ENTERPRISE



WIRELESS CARRIER



WIRELESS INTERNET SERVICE PROVIDER

LINKPlanner

LINKPlanner is a free, easy-to-use link design tool that allows network operators to easily and quickly design networks. Microsoft® Windows® and Intel®-based Mac® versions of LINKPlanner can be downloaded from Cambium Networks' support pages.

Key LINKPlanner features:

- Design a five-nines-reliable wireless link
- Plan and optimize a single link or multiple links simultaneously
- Perform calculations for both licensed and unlicensed products
- Automatically load path terrain profiles and environmental factors such as rain fade
- Display a comprehensive overview of your entire point-to-point wireless network via Google™ Earth
- Generate reports that validate projected performance and serve as time-saving deployment guidelines
- Create bills of material for point-to-multipoint and point-to-point networks including accessories

About Cambium Networks

Cambium Networks is a leading global provider of wireless connectivity solutions that strengthen connections between people, places and things. Specializing in providing an end-to-end wireless fabric of reliable, scalable, secure, cloud-managed platforms that perform under demanding conditions, Cambium Networks empowers service providers and enterprise, industrial and government network operators to build intelligent edge connectivity. Cambium Networks' commitment to continuous innovation in wireless access is demonstrated in the millions of radios deployed in thousands of networks that benefit communities around the world. Team members also contribute to social responsibility activities to serve the communities in which they live. Headquartered outside Chicago and with R&D centers in the U.S., U.K. and India, Cambium Networks sells through a range of trusted global distributors.

www.cambiumnetworks.com

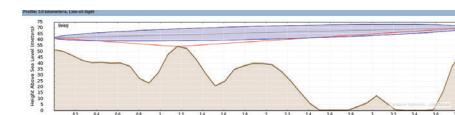

PATH PROFILE WITH OBSTRUCTIONS



GOOGLE EARTH NETWORK VIEW

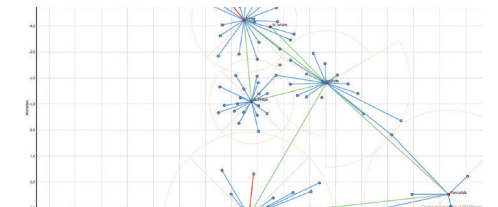

MAP OF THE SITES AND LINKS IN THE PROJECT

6 September 2021

Chief Executive Officer
Shire of Lake Grace
dsao@lakegrace.wa.go.au

Attention: Mr Alan George – Chief Executive Officer

Dear Alan,

**APPLICATION FOR DEVELOPMENT APPROVAL
PROPOSED UPGRADES & ADDITIONS TO EXISTING FARM SUPPLY CENTRE (TRADE SUPPLIES)
LOTS 146, 147 & 148 (NOS.11, 15 & 17) MAY STREET, NEWDEGATE**

King Endeavours PTY LTD ATF Ross and Jodie Dunkeld Family Trust No.2, on behalf of Nutrien Ag Solutions LTD, hereby submits an application for development approval for a number of proposed upgrades and additions to an existing farm supply centre at Nos.15 & 17 May Street, Newdegate.

Please find enclosed the following information to assist the Shire's consideration and processing of the application:

- A completed and signed Application for Development Approval form (see Attachment 1);
- Recently sourced copies of the current Certificates of Title and Deposited Plans for the subject landholdings (see Attachment 2); and
- A series of plans providing details of the proposed new development on the land (see Attachment 3).

We request that a tax invoice in respect of the development application fee payable in this particular instance be issued to **King Endeavours Pty Ltd** and forwarded to ross.dunkeld@nutrien.com.au for payment at the Shire's earliest convenience.

When assessing the application it is requested the Shire have due regard for the following key points:

1. The landowner, King Endeavours, operates as Nutrien Ag Solutions Limited which is a well-established and successful agribusiness company that offers products and services to primary producers throughout Australia, including the sale and distribution of farm merchandise, fertiliser, wool and livestock. The company also offers a range of financial, insurance, real estate and farm services.
2. The company's activities are essentially commercial in nature, which, by virtue of their scale, character and operation, require larger-sized sites from which to operate with good vehicular access.
3. The company is in the process of purchasing the property, the subject of this application with a view to expanding its current business activities in the Newdegate townsite and improve its operational efficiency and capacity.
4. Lot 148 is located in a designated service commercial precinct in the Newdegate townsite and comprises a total area of approximately 911m² which, when combined with the existing development on Lots 146 and 147 immediately east as proposed, will create a total site area of 3,795m².

5. Lots 146 and 147 May Street contain an existing 860m² warehouse building, including offices and staff amenities within, as well as portion of a large steel framed and clad storage shed. A gravel vehicle access way, parking area and landscaping are also provided on Lot 146 May Street.
6. Soils on all lots comprise a sandy topsoil, gravelly sand and weathered bedrock below with a separation distance of approximately 2.5 to 3 metres to the natural groundwater level.
7. A search of the Department of Water and Environmental Regulation's database and mapping system has confirmed the subject land is not located within a Public Drinking Water Source Area, has not been identified / registered as being subject to any form of soil contamination and is not subject to inundation or flooding during extreme storm events.
8. A search of the Department of Fire and Emergency Services website has confirmed all three (3) lots have been designated by the Fire and Emergency Services Commissioner of Western Australia as being bushfire prone which may have implications for any new buildings to be constructed on the land in the future (please note no building construction works are proposed by this application).
9. All lots are classified Service Commercial zone in the Shire of Lake Grace Local Planning Scheme No.4, the stated objectives for which are as follows:
 - i) *To provide for a range of uses which complement the Commercial zone.*
 - ii) *To accommodate wholesaling, retail warehouses, showrooms, trade centres and professional services that provide for the needs of the community but due to their nature are generally not appropriate or cannot be accommodated in the Commercial Zone; and*
 - iii) *To achieve a high standard of development and presentation including buildings, landscaping and vehicle parking.*
10. Having regard for the land use terms in the latest Planning Regulations, it is suggested the proposed development and use of the land for the purposes of a 'farm supply centre' is most appropriately classified as 'trade supplies' which is defined as follows:

Premises used to sell by wholesale or retail, or to hire, assemble or manufacture any materials, tools, equipment, machinery or other goods used for the following purposes including goods which may be assembled or manufactured off the premises:

 - i) *automotive repairs and servicing;*
 - ii) *building including repair and maintenance;*
 - iii) *industry;*
 - iv) *landscape gardening;*
 - v) *provision of medical services;*
 - vi) **primary production;** and
 - vii) *use by government departments or agencies, including local government.*
11. The use class 'trade supplies' is not listed in the Zoning Table of Local Planning Scheme No.4 which means it is not permitted unless Council is satisfied any such development is consistent with the relevant zoning objectives and has exercised its discretion by granting development approval.

12. Under the terms of this application Council's development approval is sought for the following:
- i) Use of Lot 148 for 'trade supplies' purposes to extend an existing farm supply centre being operated by Nutrien Ag Solutions Limited on Lots 146 and 147 immediately east;
 - ii) Removal of all existing vegetation and replacement with compacted gravel and blue metal to a depth of 200 – 300mm for vehicle access, parking and loading/unloading purposes;
 - iii) Installation of a new 3 metre wide landscaping strip along the southern boundary of Lot 148 and a portion of Lot 147 using drought tolerant plant species to help improve each lot's visual appearance and comply with the landscaping requirements of Local Planning Scheme No.4;
 - iv) Installation of a new 1.8 metre high chain mesh fence to provide visible security around the yard. The chain mesh fencing will match the existing chain mesh fence around the museum on the opposite side of the laneway, in so being both aesthetically pleasing and tying in with existing structures nearby;
 - v) The area south of the existing building on Lots 146 and 147 (i.e. approximately 270m²) will be sealed for vehicle unloading and loading purposes; and
 - vi) The remaining areas south and east of the existing buildings on Lots 146 and 147 will be leveled and sealed with blue metal.
13. Given the landowner's intention to store and distribute fertilisers, agricultural and veterinary chemicals on the subject land, some of which are hazardous to human health and/or the environment, the proposed development has also been carefully designed to minimise any future potential risks. Key design and management measures include:
- The placement and storage of all products inside bunded and ventilated buildings that comply with the Australian Standard requirements for bund volume and ventilation for the design quantities and the specific product types. The proposed ventilation arrangements will be in addition to any ventilation requirements specified in the National Construction Code;
 - All fertiliser and chemical storage containers will be kept closed with no products to be used for any purposes;
 - Safety shower and eye wash facilities will be installed both internally and externally to the existing warehouse / office building;
 - All chemical storage areas will be appropriately separated from the property boundaries and office / showroom areas within the building. All separation distances proposed are based on the requirements of the relevant Australian Standards;
 - The site and existing building thereon will be placarded with the appropriate dangerous goods and information signs;
 - The site will require a Dangerous Goods Site Licence with the application to be prepared by consultants accredited by the Department of Mines, Industry Regulation and Safety (DMIRS). The site will be monitored by DMIRS Dangerous Goods Inspectors, Agsafe and Nutrien Ag Solutions Safety Health and Environment Managers;
 - All staff have or will be trained in storage, handling and cleanup procedures;
 - Personal protective equipment will be provided for staff to wear during clean up procedures;
 - Spill kits will be located in both the bulk chemical storage area and smaller sized

general stock feeds storage area;

- Suitable spill absorbent material will be provided on-site at all times;
 - Safety data sheets will be provided at all times for all chemicals stored on the land to ensure suitable personal protective equipment is worn and appropriate clean up techniques are used; and
 - Recovery drums will be available on-site at all times to contain any leaking or damaged container until it can be removed for disposal in a suitable location using the appropriate methods.
14. In terms of the future proposed use of the land for the intended purpose, the following key points should also be noted:
- The use will operate from 7.30am to 5:00pm Monday to Friday, 8.00am to midday on Saturdays and will be closed on Sundays and public holidays;
 - A total of five (4) people will be employed on the land on a daily basis in either a full or part-time capacity;
 - A maximum of three (3) customers are expected to attend the site at any one time although this may increase slightly during busier periods;
 - The largest sized heavy vehicle to attend the site will be an A-Double which is an articulated truck comprising a prime mover and a semi-trailer coupled by a turntable or B-coupling with a maximum length of 20 metres
 - On average a total of two (2) heavy vehicles will attend the site each week with up to five (5) weekly visits during busy times of the year and less than one (1) in quieter times;
 - No heavy vehicles will be stored, serviced, cleaned or repaired on the land at any time.
15. No advertising signage is proposed as part of this application. A separate development application requesting the Shire's approval for all future proposed advertising signage would be prepared and submitted by a professional signage contractor once designs have been completed and authorised for use.
16. The proposed development has been designed with due regard for the relevant provisions and standards in Part 4 of Local Planning Scheme No.4 including Table 2 as it applies specifically to plot ratio, boundary setbacks, car parking and landscaping. It is contended the proposal is fully compliant with all relevant standards and requirements of the Shire's local planning framework and will result in significant improvements to the land's visual appearance and efficiency of usage.

In light of the above information and justifications, we respectfully request the Shire's favorable consideration and approval of the application at its earliest possible convenience.

Should you have any queries or require any additional information please do not hesitate to contact me on 0428 105 059 or ross.dunkeld@nutrien.com.au

Yours faithfully,

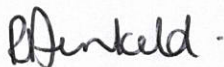

Ross Dunkeld
Director, King Endeavours PTY LTD

SHIRE OF LAKE GRACE
LOCAL PLANNING SCHEME NO.4



APPLICATION FOR DEVELOPMENT APPROVAL

Owner Details – Attach a separate sheet where there are more than two landowners		
Name/s: KING ENDEAVOURS PTY LTD ATF ROSS AND JODIE DUNKELD FAMILY TRUST №2		
ABN (if applicable): 77277 897 250		
Address: LOT 205, CHURCH AVE LAKE KING, WA		Postcode:
Phone: (work): (home): (mobile): 0428 105 059	Fax:	E-mail: ross.dunkeld@nutrien.com.au
Contact person: ROSS DUNKELD		
Signature:		Date: 12.9.21
Signature: <i>R Dunkeld</i>		Date: 12.9.21
<i>NOTE: The signature of all registered owner(s) is required on all applications. This application will not proceed without the required signature/s. For the purposes of signing this application an owner includes the persons referred to in the Planning and Development (Local Planning Schemes) Regulations 2015 Schedule 2 clause 62(2).</i>		
Applicant Details		
Name: KING ENDEAVOURS PTY LTD ATF ROSS AND JODIE DUNKELD FAMILY TRUST №2		
Address: LOT 205, CHURCH AVE LAKE KING WA		Postcode: 6356
Phone: (work): (home): (mobile): 0428 105 059	Fax:	E-mail: ross.dunkeld@nutrien.com.au rjdunkeld@bigpond.com
Contact person for correspondence: ROSS DUNKELD		
The information and plans provided with this application may be made available by the local government for public viewing in connection with the application. <input checked="" type="checkbox"/> Yes <input type="checkbox"/> No		
Signature: <i>R Dunkeld</i>		Date: 12.09.2021.

Property Details – Details must match those shown on the Certificate/s of Title		
Lot No: 147 /146	House/Street No: 15 /17	Location No: NEWDEGATE
Diagram or Plan No: 211035	Certificate of Title Volume No: 1326	Folio No: 817
Title encumbrances (e.g. easements, restrictive covenants):		
Street name: MAY ST.	Suburb: NEWDEGATE	
Nearest street intersection: COLLIER ROAD		
Proposed Development:		
Nature of development: <input type="checkbox"/> Works (New construction works with no change of land use) <input type="checkbox"/> Use (Change of use of land with no construction works) <input checked="" type="checkbox"/> Works and Use		
<i>NOTE: If the proposal involves advertising signage the Additional Information for Development Approval for Advertisements form must be completed and submitted with this application.</i>		
Is an exemption from development claimed for part of the development? <input type="checkbox"/> Yes <input checked="" type="checkbox"/> No		
If yes, is the exemption for: <input type="checkbox"/> Works <input type="checkbox"/> Use		
Description of proposed works and/or land use: This application forms part of the application to develop Lot 148 May St.		
Description of exemption claimed (if relevant):		
Nature of any existing buildings and/or land use:		
Approximate cost of proposed development: \$50,000.00		
Estimated time of completion: NOVEMBER 30 th 2021		
OFFICE USE ONLY		
Acceptance Officer's initials:	Date received:	
Local government reference no:		

SHIRE OF LAKE GRACE
LOCAL PLANNING SCHEME NO.4



APPLICATION FOR DEVELOPMENT APPROVAL

Owner Details – Attach a separate sheet where there are more than two landowners		
Name/s: WESTERN AUSTRALIAN LAND AUTHORITY (TRADING AS DEVELOPMENTWA)		
ABN (if applicable): 34 868 192 835		
Address: 40 THE ESPLANADE PERTH WA		Postcode: 6000
Phone: (work): 9482 7499 (home): (mobile):	Fax:	E-mail: contact@developmentwa. com.au
Contact person: ROBERT FENN (0428 984 538)		
Signature:		Date:
Signature:		Date: 9/9/21
<p>NOTE: The signature of all registered owner(s) is required on all applications. This application will not proceed without the required signature/s. For the purposes of signing this application an owner includes the persons referred to in the Planning and Development (Local Planning Schemes) Regulations 2015 Schedule 2 clause 62(2).</p>		
Applicant Details		
Name: KING ENDEAVOURS PTY LTD ATF ROSS AND JODIE DUNKELD FAMILY TRUST № 2		
Address: LOT 205, CHURCH AVE LAKE KING WA		Postcode: 6356
Phone: (work): (home): (mobile): 0428 105 059	Fax:	E-mail: ross.dunkeld@nutrien. com.au rjdunkeld@bigpond.com
Contact person for correspondence: ROSS DUNKELD		
The information and plans provided with this application may be made available by the local government for public viewing in connection with the application. <input checked="" type="checkbox"/> Yes <input type="checkbox"/> No		
Signature:		Date: 9-9-21

Property Details – Details must match those shown on the Certificate/s of Title		
Lot No: 148	House/Street No: 11	Location No:
Diagram or Plan No: 211035	Certificate of Title Volume No: 2561	Folio No: 543
Title encumbrances (e.g. easements, restrictive covenants):		
Street name: MAY	Suburb: NEWDEGATE	
Nearest street intersection: COLLIER STREET		
Proposed Development:		
Nature of development: <input type="checkbox"/> Works (New construction works with no change of land use) <input type="checkbox"/> Use (Change of use of land with no construction works) <input checked="" type="checkbox"/> Works and Use		
<i>NOTE: If the proposal involves advertising signage the Additional Information for Development Approval for Advertisements form must be completed and submitted with this application.</i>		
Is an exemption from development claimed for part of the development? <input type="checkbox"/> Yes <input checked="" type="checkbox"/> No		
If yes, is the exemption for: <input type="checkbox"/> Works <input type="checkbox"/> Use		
Description of proposed works and/or land use: we intend to clear the block, leaving existing trees on May st. We will be fencing the block with chain mesh fencing. The land will be used for Trade Supply purposes associated with the existing development on Nos 15 and 17 May St. Newdegate.		
Description of exemption claimed (if relevant):		
Nature of any existing buildings and/or land use:		
Approximate cost of proposed development: \$50 000		
Estimated time of completion: November 30th 2021		
OFFICE USE ONLY		
Acceptance Officer's initials:	Date received:	
Local government reference no:		



PROPOSED SITE DEVELOPMENT PLAN

LOT 146-148 (No. 11, 15 & 17) MAY STREET
NEWDEGATE
Shire of Lake Grace

- LEGEND:**
- Trees (Green cloud icon)
 - Landscaping (Green square icon)
 - Vehicle Flow (Arrow icon)

DATE: 30.08.2021

- Note:**
- The proposed yard will be fenced with 1.8m high chain mesh fencing.
 - The proposed yard will be a gravel base with a crusher dust surface.
 - Landscaping & trees make up approx. 380m² or 10%. Landscaping to be made up of drought tolerant species.

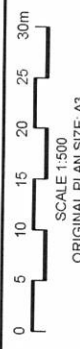

PREPARED FOR:
Nutrien Ag Solutions
Mr Ross Durkeld
M 0428 105 659
E ross.durkeld@nutrien.com.au

NOTE:
Dimensions and areas subject to survey



WESTERN



AUSTRALIA

REGISTER NUMBER	
148/DP211035	
DUPLICATE EDITION	DATE DUPLICATE ISSUED
1	14/4/2004

RECORD OF CERTIFICATE OF TITLE
UNDER THE TRANSFER OF LAND ACT 1893

VOLUME 2561 FOLIO 543

The person described in the first schedule is the registered proprietor of an estate in fee simple in the land described below subject to the reservations, conditions and depth limit contained in the original grant (if a grant issued) and to the limitations, interests, encumbrances and notifications shown in the second schedule.

BGRoberts
REGISTRAR OF TITLES

**LAND DESCRIPTION:**

LOT 148 ON DEPOSITED PLAN 211035

REGISTERED PROPRIETOR:
(FIRST SCHEDULE)

WESTERN AUSTRALIAN LAND AUTHORITY OF LEVEL 3, 40 THE ESPLANADE, PERTH.
(TF I775660) REGISTERED 2/4/2004

LIMITATIONS, INTERESTS, ENCUMBRANCES AND NOTIFICATIONS:
(SECOND SCHEDULE)

Warning: A current search of the sketch of the land should be obtained where detail of position, dimensions or area of the lot is required.
* Any entries preceded by an asterisk may not appear on the current edition of the duplicate certificate of title.
Lot as described in the land description may be a lot or location.

-----END OF CERTIFICATE OF TITLE-----

STATEMENTS:

The statements set out below are not intended to be nor should they be relied on as substitutes for inspection of the land and the relevant documents or for local government, legal, surveying or other professional advice.



SKETCH OF LAND: LR3030-8 (148/DP211035)
PREVIOUS TITLE: LR3030-8
PROPERTY STREET ADDRESS: 11 MAY ST, NEWDEGATE.
LOCAL GOVERNMENT AUTHORITY: SHIRE OF LAKE GRACE
RESPONSIBLE AGENCY: WESTERN AUSTRALIAN LAND AUTHORITY

R. Berkeld.
J. Berkeld
8/9/2021.

**SHIRE OF LAKE GRACE
LOCAL PLANNING SCHEME NO.4**



APPLICATION FOR DEVELOPMENT APPROVAL

Owner Details – Attach a separate sheet where there are more than two landowners		
Name/s: LOUIS GREYLING IDRA GREYLING		
ABN (if applicable): 41 496 194 437		
Address: 2 McCracken Road Newdegate, WA, 6355		Postcode:
Phone: (work): (home): (mobile): 0488584482	Fax:	E-mail: pitstopmts@gmail.com
Contact person: LOUIS GREYLING		
Signature: 	Date: 18/08/2021	
Signature: 	Date: 18.08.2021	
NOTE: The signature of all registered owner(s) is required on all applications. This application will not proceed without the required signature/s. For the purposes of signing this application an owner includes the persons referred to in the Planning and Development (Local Planning Schemes) Regulations 2015 Schedule 2 clause 62(2).		
Applicant Details		
Name: LOUIS GREYLING		
Address: 2 McCracken Road Newdegate, WA, 6355		Postcode:
Phone: (work): (home): (mobile): 0488584482	Fax:	E-mail: pitstopmts@gmail.com
Contact person for correspondence: LOUIS GREYLING		
The information and plans provided with this application may be made available by the local government for public viewing in connection with the application. <input checked="" type="checkbox"/> Yes <input type="checkbox"/> No		
Signature: 	Date: 18.08.2021	

Property Details – Details must match those shown on the Certificate/s of Title		
Lot No: 175	House/Street No: 2	Location No: 175
Diagram or Plan No: 216036	Certificate of Title Volume No: 1843	Folio No: 387
Title encumbrances (e.g. easements, restrictive covenants): N/A-		
Street name: McCRACKEN ROAD	Suburb: NEWDEGATE	
Nearest street intersection: NGT North Rd / Mc Cracken RD.		
Proposed Development:		
Nature of development: <input checked="" type="checkbox"/> Works (New construction works with no change of land use) <input type="checkbox"/> Use (Change of use of land with no construction works) <input type="checkbox"/> Works and Use		
<i>NOTE: If the proposal involves advertising signage the Additional Information for Development Approval for Advertisements form must be completed and submitted with this application.</i>		
Is an exemption from development claimed for part of the development? <input type="checkbox"/> Yes <input checked="" type="checkbox"/> No		
If yes, is the exemption for: <input type="checkbox"/> Works <input type="checkbox"/> Use		
Description of proposed works and/or land use: Extensions to main shed Extension to garage Fencing around property		
Description of exemption claimed (if relevant): N/A		
Nature of any existing buildings and/or land use: Service Commercial Shed + Caretaker Cottage		
Approximate cost of proposed development: ± \$25 000		
Estimated time of completion: ± 30/11/21		
OFFICE USE ONLY		
Acceptance Officer's initials:		Date received:
Local government reference no:		

WESTERN



AUSTRALIA

REGISTER NUMBER 175/DP216036	
DUPLICATE EDITION N/A	DATE DUPLICATE ISSUED N/A

RECORD OF CERTIFICATE OF TITLE
UNDER THE TRANSFER OF LAND ACT 1893

VOLUME **1843** FOLIO **387**

The person described in the first schedule is the registered proprietor of an estate in fee simple in the land described below subject to the reservations, conditions and depth limit contained in the original grant (if a grant issued) and to the limitations, interests, encumbrances and notifications shown in the second schedule.

BGRoberts
REGISTRAR OF TITLES



LAND DESCRIPTION:

LOT 175 ON DEPOSITED PLAN 216036

REGISTERED PROPRIETOR:
(FIRST SCHEDULE)

LOUIS HENDRIK GREYLING
IDRA GREYLING
BOTH OF PO BOX 147 NEWDEGATE WA 6355
AS JOINT TENANTS

(TP 0836260) REGISTERED 13/8/2021

LIMITATIONS, INTERESTS, ENCUMBRANCES AND NOTIFICATIONS:
(SECOND SCHEDULE)

- *O836261 MORTGAGE TO COUNTRY HOUSING AUTHORITY OF 502 HAY STREET SUBIACO WA 6008 REGISTERED 13/8/2021.

Warning: A current search of the sketch of the land should be obtained where detail of position, dimensions or area of the lot is required.
* Any entries preceded by an asterisk may not appear on the current edition of the duplicate certificate of title.
Lot as described in the land description may be a lot or location.

-----END OF CERTIFICATE OF TITLE-----

STATEMENTS:

The statements set out below are not intended to be nor should they be relied on as substitutes for inspection of the land and the relevant documents or for local government, legal, surveying or other professional advice.

SKETCH OF LAND: 1843-387 (175/DP216036)
PREVIOUS TITLE: 1843-387
PROPERTY STREET ADDRESS: 2 MCCRACKEN RD, NEWDEGATE.
LOCAL GOVERNMENT AUTHORITY: SHIRE OF LAKE GRACE

NOTE 1: DUPLICATE CERTIFICATE OF TITLE NOT ISSUED AS REQUESTED BY DEALING L242648

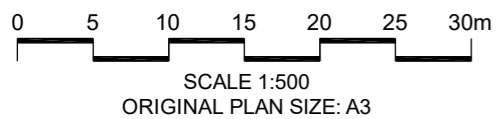
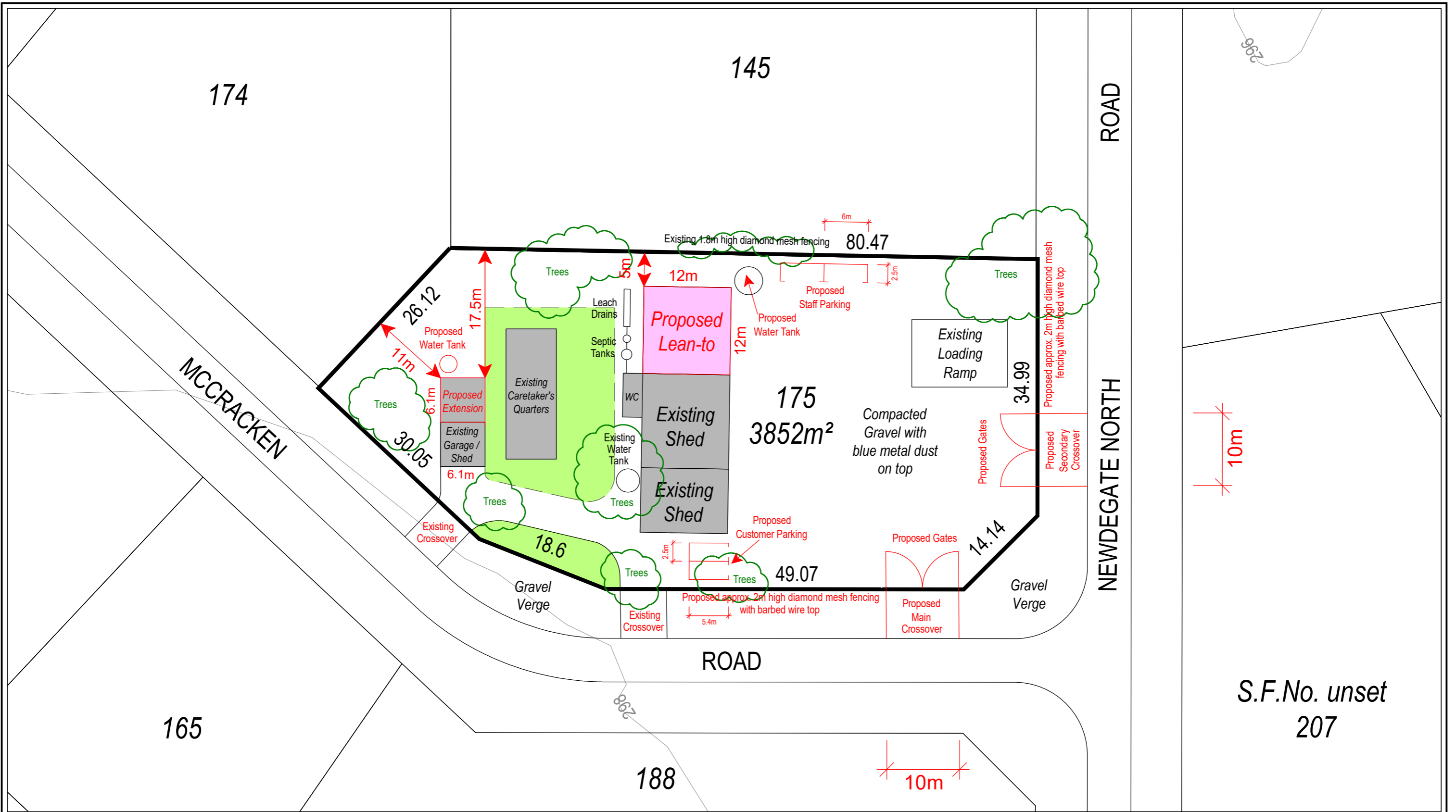



NORTH

PREPARED FOR:
Mr Louis Greyling
Pitstop Mechanical and Tyre Services
M
E pitstopmts@gmail.com

NOTE:
Dimensions and areas subject
to survey.

- Note:
1. Stormwater is to be captured in proposed rainwater tanks.
 2. New lean-to is to be zincalume (to match existing shed) on an existing concrete slab.
 3. Extension to existing garage/shed will be Zincalume to match existing building on a proposed concrete slab.
 4. There will be 2 staff parking bays and 2 customer parking bays provided.
 5. Proposed total site coverage will be 620m² (16%)
 6. Proposed crossovers will be constructed to Shire's specifications.
 7. Landscaping & trees make up approx. 900m² or 23%

DATE: 24.08.2021

LEGEND:
Landscaping 
Trees 

PROPOSED SITE DEVELOPMENT PLAN

LOT 175 (No.2) McCracken Road
NEWDEGATE
Shire of Lake Grace

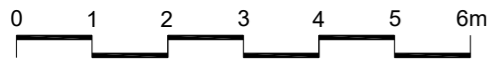
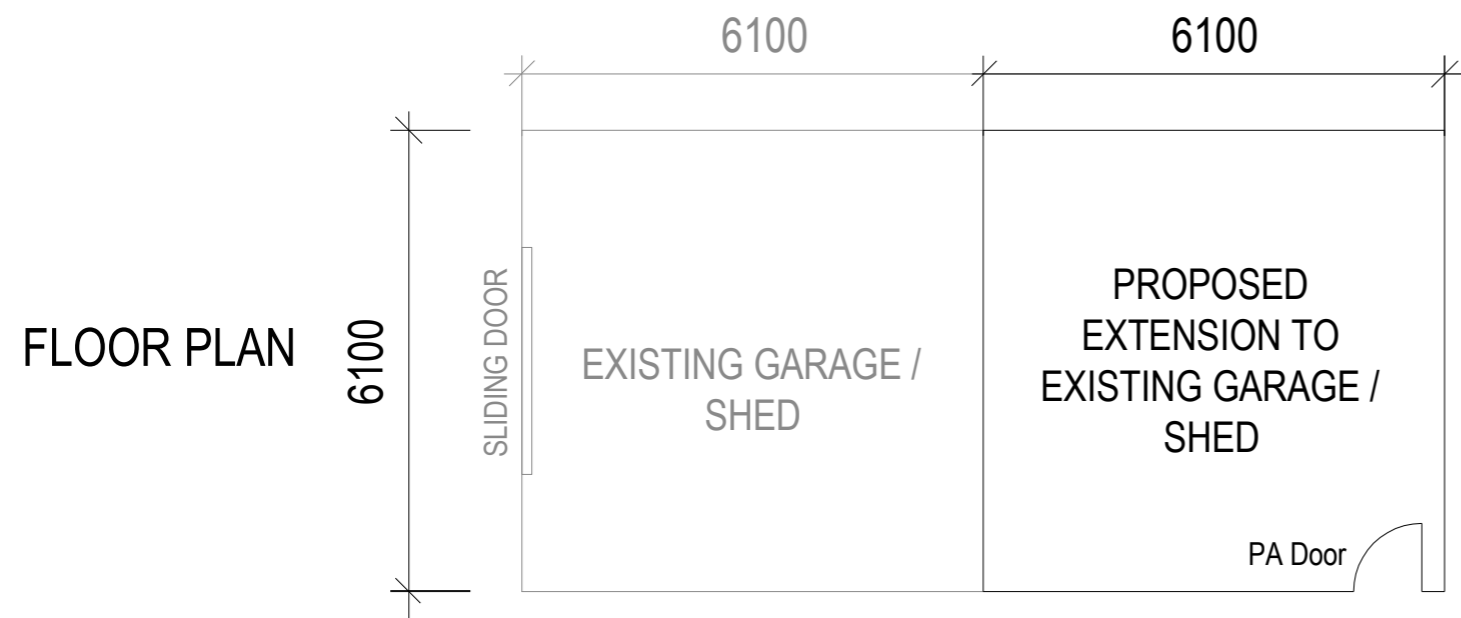
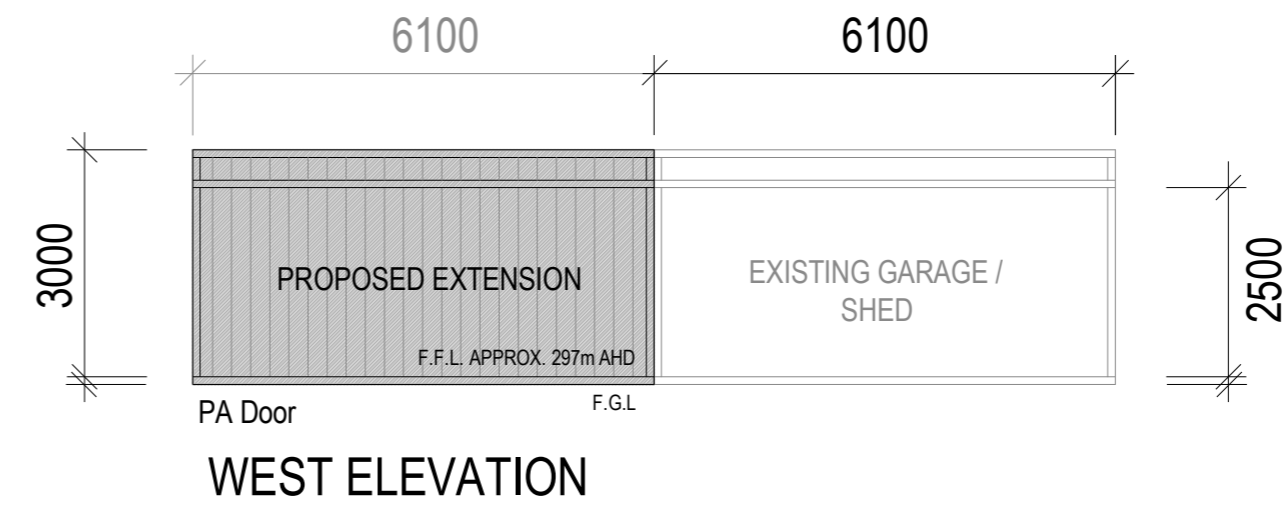
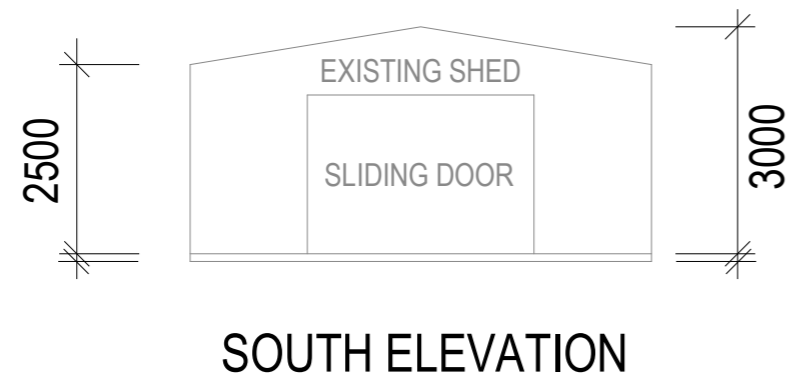
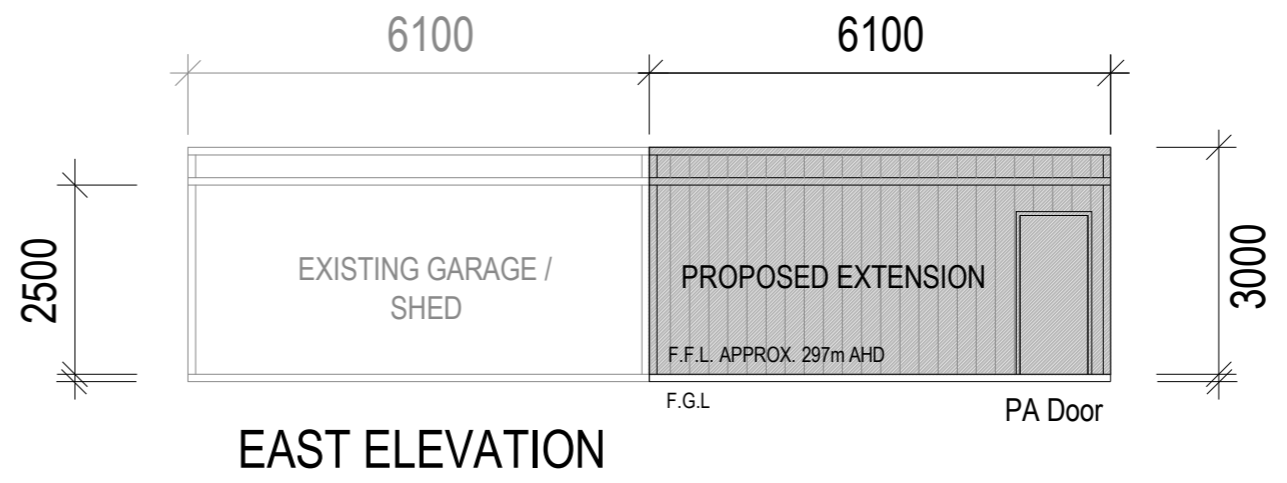
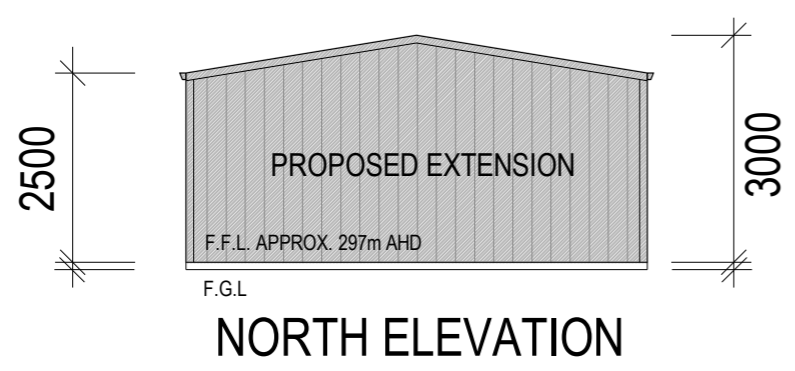

SCALE 1:100
ORIGINAL PLAN SIZE: A3

PREPARED FOR:
Mr Louis Greyling
Pitstop Mechanical and Tyre Services
PH (08) 9871 1398
E pitstopmts@gmail.com
NOTE:
Dimensions and areas subject to survey.

LEGEND:

- F.F.L. - FINISHED FLOOR LEVEL
- F.G.L. - FINISHED GROUND LEVEL
- PROPOSED EXTENSION WALLS AND ROOF WILL BE CLAD WITH ZINCULUME TRIMDEK SHEETING ON A 100mm CONCRETE SLAB
- DATE: 23.08.2021

PROPOSED EXTENSION TO GARAGE/SHED ELEVATIONS & FLOOR PLAN

LOT 175 (No.2) McCRACKEN ROAD
NEWDEGATE
Shire of Lake Grace

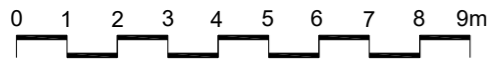
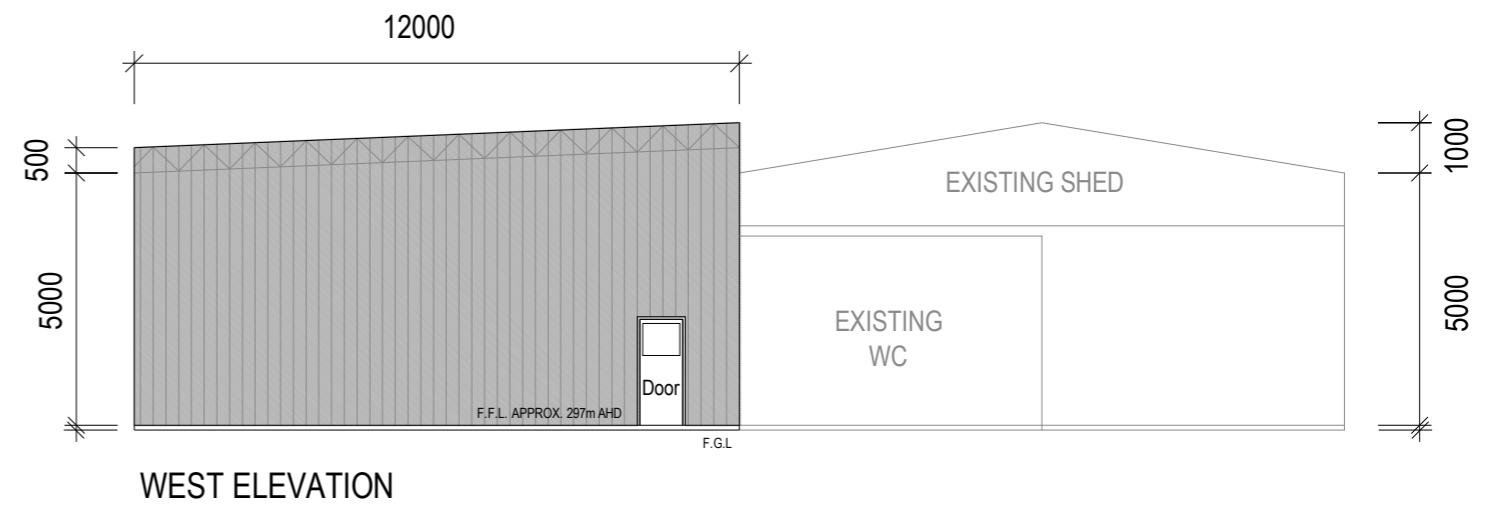
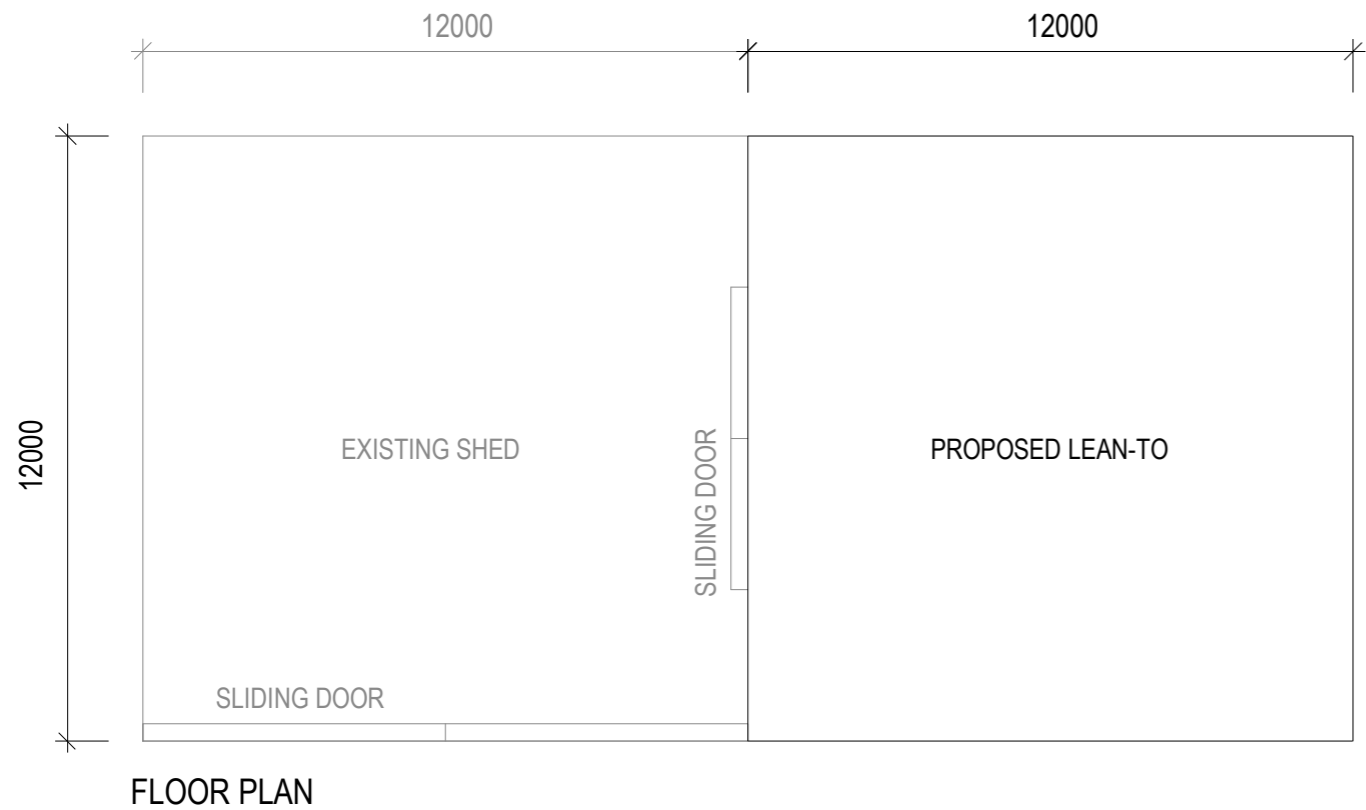
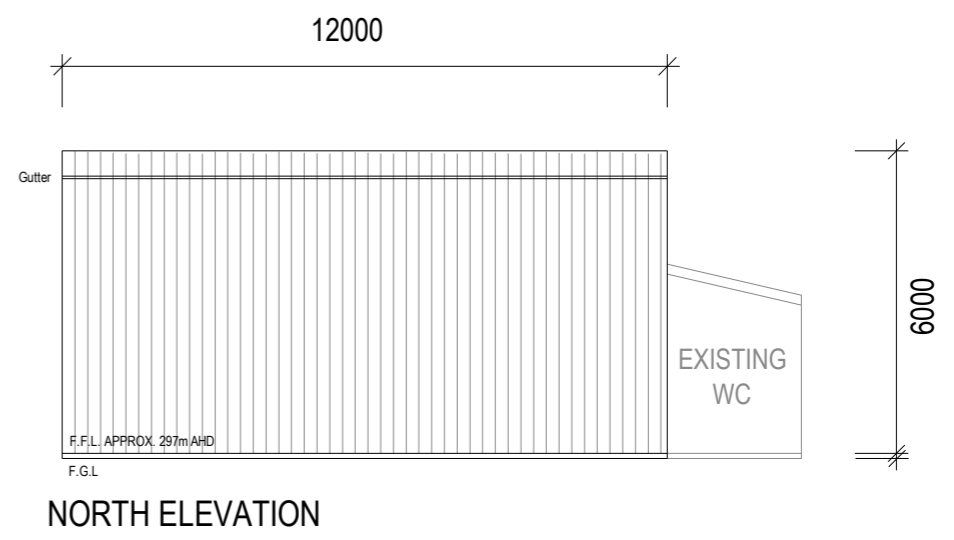
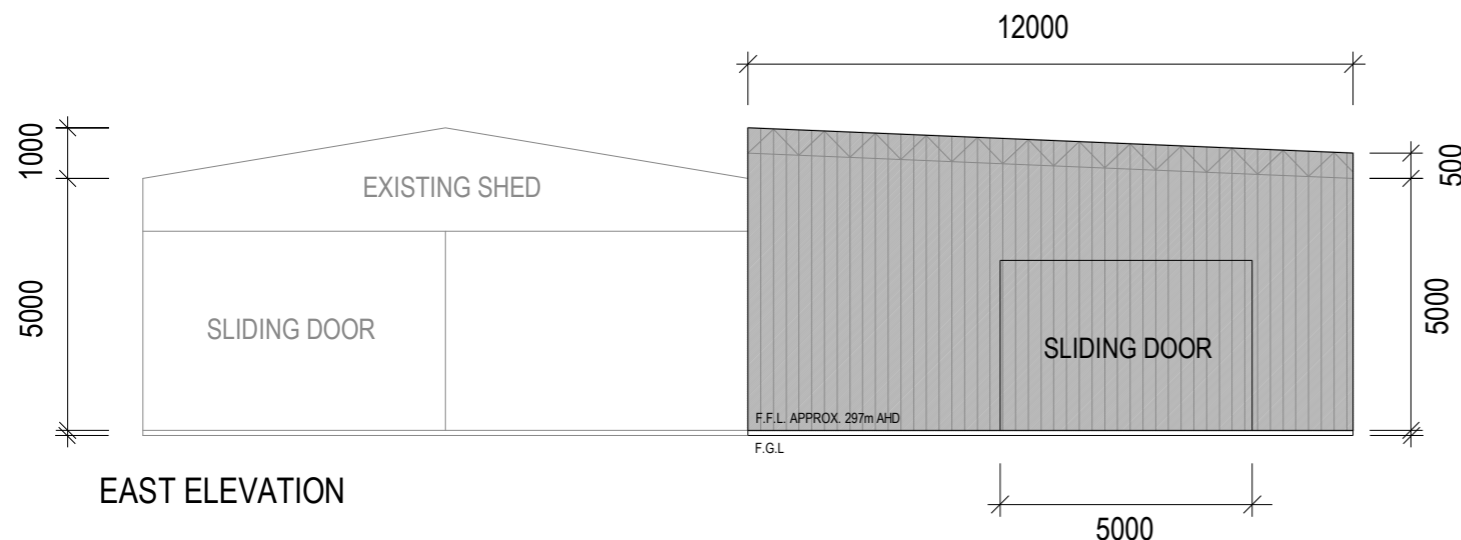

SCALE 1:150
ORIGINAL PLAN SIZE: A3

PREPARED FOR:
Mr Louis Greyling
Pitstop Mechanical and Tyre Services
PH (08) 9871 1398
E pitstopmts@gmail.com
NOTE:
Dimensions and areas subject
to survey.

LEGEND:

- F.F.L. - FINISHED FLOOR LEVEL
- F.G.L. - FINISHED GROUND LEVEL
- LEAN-TO WALLS AND ROOF WILL BE CLAD WITH ZINCULUME TRIMDEK SHEETING ON A 100mm CONCRETE SLAB

DATE: 20.08.2021

**PROPOSED LEAN-TO
ELEVATIONS & FLOOR PLAN**

**LOT 175 (No.2) McCracken Road
Newdegate
Shire of Lake Grace**

MUNICIPAL FUND

Chq/EFT	Date	Description	Amount	
EFT22724	12/10/2021	Grillex Pty Ltd		-\$ 59,388.45
	24/09/2021	BBQ shelter packs for driver reviver grant	\$ 59,388.45	
EFT22725	12/10/2021	Michelle Slarke		-\$ 7,623.00
	04/10/2021	interpretive signage & production & brochures for the community walking trials	\$ 7,623.00	
EFT22726	12/10/2021	Safe Roads WA Division of R&J Haulage Pty Ltd		-\$ 172,849.60
	25/09/2021	Sealing/patching works on Nrth Lake Grace Karlgarin Road and new sprayed footpaths in LG	\$ 172,849.60	
EFT22727	12/10/2021	Trevenen Building & Glass Pty Ltd		-\$ 43,850.25
	04/10/2021	Refurbishment & alterations to the Newdegate Country Club - September Claim	\$ 43,850.25	
EFT22728	12/10/2021	Western Power		-\$ 3,300.00
	26/09/2021	Design Fee for New Power Dome for Newdegate Country Club	\$ 3,300.00	
EFT22750	15/10/2021	360 Environmental		-\$ 11,836.00
	07/10/2021	Detailed Site Investigation of Lions Walk Trail	\$ 11,836.00	
EFT22751	15/10/2021	ABA Security and Electrical		-\$ 155.86
	04/10/2021	LG Medical Centre - Alarm Monitoring from October 2021 to December 2021	\$ 155.86	
EFT22752	15/10/2021	AFGRI Equipment Australia		-\$ 734.80
	16/09/2021	100hr service on PTOR09 2018 John Deere Tractor	\$ 734.80	
EFT22753	15/10/2021	Anna Scheepers		-\$ 200.00
	25/09/2021	Cleaning of Varley Hall 13/09-24/09/2021	\$ 200.00	
EFT22754	15/10/2021	Australia Post		-\$ 152.12
	03/10/2021	Postage & Freight Sep 2021	\$ 152.12	
EFT22755	15/10/2021	BGC Cement		-\$ 5,610.00
	29/09/2021	Bulker bags of cement	\$ 5,610.00	
EFT22756	15/10/2021	BOC Gases Australia Limited		-\$ 12.14
	28/09/2021	Container Service: LG Pool	\$ 12.14	
EFT22757	15/10/2021	CCL Hardware		-\$ 1,918.15
	29/09/2021	Cleaning supplies for LG Airstrip and Lakes Village Hall	\$ 63.10	
	30/09/2021	September monthly building mtc materials	\$ 1,855.05	
EFT22758	15/10/2021	CHILD SUPPORT AGENCY		-\$ 316.98
	29/09/2021	Payroll deductions	\$ 158.49	
	13/10/2021	Payroll deductions	\$ 158.49	
EFT22759	15/10/2021	CJD Equipment Pty Ltd		-\$ 2,796.22
	11/10/2021	Cutting edge kit for PLOD07 Volvo Loader	\$ 1,398.11	
	11/10/2021	Cutting edge kit for PLOD07 Volvo Loader	\$ 1,398.11	
EFT22760	15/10/2021	Cr Allan Douglas Marshall		-\$ 487.76
	30/09/2021	Councillor's Meeting Fees, Travel & IT Allowance	\$ 487.76	
EFT22761	15/10/2021	Cr Benjamin John Hyde		-\$ 500.00
	30/09/2021	Councillor's Meeting Fees & IT Allowance	\$ 500.00	
EFT22762	15/10/2021	Cr Debrah Susan Clarke		-\$ 500.00
	30/09/2021	Councillor's Meeting Fees & IT Allowance	\$ 500.00	
EFT22763	15/10/2021	Cr Leonard William Armstrong		-\$ 3,661.29
	30/09/2021	President's Meeting Fees, Travel & IT Allowance	\$ 3,661.29	
EFT22764	15/10/2021	Cr Rosalind Alice Lloyd		-\$ 583.08
	30/09/2021	Councillor's Meeting Fees, Travel & IT Allowance	\$ 583.08	
EFT22765	15/10/2021	Cr Ross Chappell		-\$ 1,703.32
	30/09/2021	Deputy President's Meeting Fees, Travel & IT Allowances	\$ 1,703.32	
EFT22766	15/10/2021	Cr Salomon Petrus Stoffberg		-\$ 500.00
	30/09/2021	Councillor's Meeting Fees & IT Allowance	\$ 500.00	
EFT22767	15/10/2021	Cr Shane David Carruthers		-\$ 500.00
	30/09/2021	Councillor's Meeting Fees & IT Allowance	\$ 500.00	

EFT22768	15/10/2021	Cutting Edges Equipment Parts Pty Ltd		-\$	282.15
	30/09/2021	Tooth scarifiers for PGRA07 2015 John Deere grader & PGRA08 2020 CAT grader	\$	282.15	
EFT22769	15/10/2021	Davmin Holdings Pty Ltd		-\$	6,006.00
	30/09/2021	Dozer hire for NGT Tip	\$	6,006.00	
EFT22770	15/10/2021	Department of Fire and Emergency Services		-\$	6,777.24
	28/09/2021	ESL 2nd Qtr Contribution	\$	6,777.24	
EFT22771	15/10/2021	Enviro Pipes		-\$	19,437.16
	29/09/2021	Supply of HDPE pipes for drainage & stormwater works	\$	12,992.04	
	30/09/2021	Supply of HDPE pipes for drainage & stormwater works	\$	6,445.12	
EFT22772	15/10/2021	Exteria		-\$	5,632.00
	30/09/2021	Supply of picnic shelter for NGT Cemetery	\$	5,632.00	
EFT22773	15/10/2021	Exurban Pty Ltd		-\$	1,788.94
	05/10/2021	General Town Planning Consulting Services provided during September 2021	\$	1,788.94	
EFT22774	15/10/2021	Farmyard Pantry		-\$	340.00
	05/10/2021	Catering for First Aid Course	\$	340.00	
EFT22775	15/10/2021	Fyfe Transport		-\$	4,379.92
	30/09/2021	Supply & delivery of sand & crusher dust	\$	4,379.92	
EFT22776	15/10/2021	Great Southern Fuel Supplies		-\$	2,319.30
	30/09/2021	Fuel Card Purchases Sep 21	\$	2,319.30	
EFT22777	15/10/2021	Hopetoun Plumbing & Gas		-\$	2,871.00
	04/10/2021	Pump out and cleaning of Biomax Septic system	\$	2,871.00	
EFT22778	15/10/2021	Integrated ICT		-\$	2,267.21
	30/09/2021	IT Support Sep 21	\$	1,870.55	
	30/09/2021	Office 365 - Licenses Sep 21	\$	396.66	
EFT22779	15/10/2021	Ipec Pty Ltd		-\$	126.66
	29/08/2021	Freight - 19/08/2021	\$	23.34	
	06/09/2021	Freight 01/09/2021	\$	90.27	
	12/09/2021	Freight 31/08/2021	\$	13.05	
EFT22780	15/10/2021	Jason Signmakers		-\$	309.10
	11/10/2021	Rural roads signage	\$	185.59	
	13/10/2021	Replacement town street signs	\$	123.51	
EFT22781	15/10/2021	Lake Grace Community Resource Centre		-\$	102.50
	30/09/2021	3 x adverts in the Lakes Link News	\$	102.50	
EFT22782	15/10/2021	Lake Grace District High School		-\$	2,368.61
	13/10/2021	25% Library Co-Ordinator Wage Term 4 & Relief Library Coordinator wage	\$	2,368.61	
EFT22783	15/10/2021	Lake Grace Plaza		-\$	53.70
	30/09/2021	Newspapers Subscription Sep 21	\$	53.70	
EFT22784	15/10/2021	Lake Grace Transport		-\$	19.78
	26/09/2021	Freight of soap dispensers for Jam Patch	\$	19.78	
EFT22785	15/10/2021	Lake King Agencies		-\$	289.65
	29/09/2021	Cleaning supplies for LK Public Toilets	\$	289.65	
EFT22786	15/10/2021	Lake Varley & Districts Progress Association		-\$	172.57
	15/09/2021	2020 Electricity & Insurance (1/3 share)	\$	172.57	
EFT22787	15/10/2021	Landgate		-\$	173.88
	29/09/2021	Rural Valuations Chargeable 29/05-17/09/2021	\$	173.88	
EFT22788	15/10/2021	M & L Australasia PTY LTD		-\$	23.05
	07/10/2021	Engraving of name Badges for new Councillors	\$	23.05	
EFT22789	15/10/2021	Maalouf Ford		-\$	635.13
	02/08/2021	Lakes Local Action Group - 75,000km service on 2017 Ranger	\$	635.13	
EFT22790	15/10/2021	Marketforce Productions		-\$	2,337.02
	27/09/2021	Advert in The West Australian for Swimming Pool Manager	\$	870.17	
	27/09/2021	Advert for Manager Corporate Services in West Australian	\$	1,690.83	
EFT22791	15/10/2021	Marshall Mowers		-\$	242.75
	08/10/2021	Mower blades for PTOR08 2021 Hustler Slasher	\$	242.75	

EFT22792	15/10/2021	Neu-Tech Auto Electrics		-\$	312.51
	31/07/2021	Lake Local Action Group - Replace battery in Ford Ranger	\$	312.51	
EFT22793	15/10/2021	NewGround Water Services		-\$	26,065.38
	28/08/2021	Soil samples for coring of LG, NGT & LK Rec Ovals	\$	1,287.00	
	31/08/2021	Supply & installation of dosing units and monitoring of equipment	\$	24,778.38	
EFT22794	15/10/2021	Newdegate Football Club		-\$	259.50
	06/10/2021	Refreshments for the Bush Fire Advisory Committee meeting	\$	259.50	
EFT22795	15/10/2021	Newdegate Newsagency & PO		-\$	44.00
	29/09/2021	Postage of Inter-Library books September 2021	\$	44.00	
EFT22796	15/10/2021	Newdegate Primary School		-\$	216.00
	12/10/2021	Reimbursement of Electricity Usage 50% for NGT Library/CRC	\$	216.00	
EFT22797	15/10/2021	Newdegate Stock & Trading		-\$	21,365.23
	08/09/2021	Garden hose for pioneer park	\$	44.00	
	10/09/2021	Diesel for fogger	\$	35.28	
	13/09/2021	Wetter soil for NGT parks & gardens	\$	79.20	
	22/09/2021	Purchase of unleaded & distillate for misc small plant	\$	155.68	
	04/10/2021	Supply and delivery of bulk diesel	\$	21,051.07	
EFT22798	15/10/2021	OneMusic Australia		-\$	88.22
	02/10/2021	Music for Councils - Rural LGA 01/10-31/12/2021	\$	88.22	
EFT22799	15/10/2021	Outback TV		-\$	288.87
	27/09/2021	Replacing solar HWS with electric pump HWS at 10B Gumtree Drive	\$	288.87	
EFT22800	15/10/2021	Roamin Enterprises		-\$	20,817.50
	29/09/2021	Culvert & drainage work on Purnta & Carstairs Road	\$	20,817.50	
EFT22801	15/10/2021	S & L Trevenen		-\$	89,837.00
	08/10/2021	Maintenance Grading: Newdegate: 30/08-30/09/2021	\$	55,247.50	
	08/10/2021	Maintenance Grading: Lake King - Varley: 01-30/09/2021	\$	34,589.50	
EFT22802	15/10/2021	Shire of Corrigin		-\$	9,703.10
	06/10/2021	Roe Regional Environmental Health services scheme - July to September 2021	\$	9,703.10	
EFT22803	15/10/2021	South Regional TAFE		-\$	1,152.30
	08/10/2021	Skid steer & front end loader course for infrastructure operators	\$	1,152.30	
EFT22804	15/10/2021	State Library Of Western Australia		-\$	137.50
	25/08/2021	Better Beginnings Program 2021-22	\$	137.50	
EFT22805	15/10/2021	Urbaqua Ltd		-\$	8,624.00
	30/09/2021	Phase 1 of Feasibility Survey of Padley Park stormwater harvest project	\$	8,624.00	
EFT22806	15/10/2021	Varley Ag Solutions		-\$	11,211.20
	08/10/2021	Materials for Varley entry statement	\$	11,211.20	
EFT22807	15/10/2021	WA Contract Ranger Services		-\$	1,028.50
	10/10/2021	Contract Ranger Services	\$	1,028.50	
EFT22808	15/10/2021	Warren Blackwood Waste		-\$	8,224.00
	03/10/2021	Recycling Pickup Sep 21	\$	4,364.80	
	03/10/2021	Residential & Street Bins Pick Ups Sep 21	\$	3,859.20	
EFT22809	15/10/2021	Wazzas Complete Sheep Management		-\$	7,969.50
	03/10/2021	NGT Town Maintenance And Gardening 01/09/2021-01/10/2021	\$	7,969.50	
EFT22810	18/10/2021	Daves Tree Service		-\$	13,772.00
	09/10/2021	Corridor clearing on North Lake Grace-Karlgarin Rd	\$	13,772.00	
EFT22811	18/10/2021	LGISWA		-\$	108,141.88
	30/09/2021	LGIS Liability 2nd Instalment 30/06/2021 To 30/06/2022	\$	28,845.09	
	30/09/2021	LGIS Workcare - Instalment 2	\$	25,769.54	
	30/09/2021	LGIS Property - Instalment 2	\$	57,092.82	
	05/10/2021	2021/22 Contributions Credit Note - Second Instalment 30/06/2021 To 30/06/2022	-\$	3,565.57	

EFT22812	18/10/2021	Telstra Corporation Limited		-\$	2,158.04
	04/10/2021	0407384735-Sewerage-Fail Safe	\$	23.80	
	04/10/2021	0408411920-Sewerage-Fail Safe	\$	0.06	
	04/10/2021	0418621708-CEO Mobile	\$	30.17	
	04/10/2021	0417914083-Speed Trailer	\$	5.50	
	04/10/2021	0418326588-LG Pool Manager	\$	0.33	
	04/10/2021	0428651109-Leading Hand Mobile	\$	0.22	
	04/10/2021	0428711190-Newdegate Fire Truck	\$	0.11	
	04/10/2021	0429571975-Sewerage	\$	41.50	
	04/10/2021	0429651112-Parks & Gardens Mobile	\$	0.06	
	04/10/2021	0436668242-CESM Mobile	\$	116.08	
	04/10/2021	0448089092-MIS Mobile	\$	162.96	
	04/10/2021	0475898471-Councillors WI-FI	\$	40.00	
	04/10/2021	0476806205-Councillors Air Card	\$	44.99	
	04/10/2021	Rounding	-\$	0.01	
	12/10/2021	Landline Charges Depot - 9865 1067	\$	34.95	
	12/10/2021	Lake Grace Pool - 9865 1144	\$	34.95	
	12/10/2021	Lake Grace Library - 9865 1185	\$	95.60	
	12/10/2021	Lake Grace Medical Centre - 9865 1208	\$	113.52	
	12/10/2021	Lake Grace Medical Centre Fax - 9865 1362	\$	50.06	
	12/10/2021	Lake Grace Medical Centre - 9865 1388	\$	45.88	
	12/10/2021	Depot - 9865 1493	\$	34.95	
	12/10/2021	AIM - 9865 1646	\$	35.54	
	12/10/2021	Lake Grace Airstrip - 9865 1656	\$	34.95	
	12/10/2021	338 Memorial Drive - 9865 1978	\$	88.59	
	12/10/2021	Depot - 9865 1985	\$	34.95	
	12/10/2021	Depot - 9865 1986	\$	34.95	
	12/10/2021	Licensing Telecentre - 9865 2032	\$	-	
	12/10/2021	338 Memorial Drive - 9865 2101	\$	-	
	12/10/2021	Lake Grace Visitor Centre - 9865 2140	\$	39.54	
	12/10/2021	Lake Grace Visitor Centre Fax - 9865 2141	\$	34.95	
	12/10/2021	Licensing Office - 9865 2275	\$	34.95	
	12/10/2021	Newdegate Medical Centre - 9871 1105	\$	36.90	
	12/10/2021	Newdegate Medical Centre - 9871 1341	\$	37.50	
	12/10/2021	Newdegate Medical Centre - 9871 1528	\$	62.33	
	12/10/2021	Lake King Library - 9874 4147	\$	35.10	
	12/10/2021	Lake King Fire Station - 9874 4196	\$	34.95	
	12/10/2021	Lake King Fire Station Fax - 9874 4201	\$	34.95	
	12/10/2021	Lake King Library Internet - 9874 4234	\$	34.95	
	12/10/2021	0427651127- TO Mobile - GST incl \$65	\$	99.00	
	12/10/2021	0455915715-IPad for OSH - GST incl \$11	\$	29.00	
	12/10/2021	Fire Ban Hotline - 9487 7191	\$	6.00	
	12/10/2021	Administration Office - 9880 2500	\$	383.89	
	12/10/2021	Lake Grace Medical Centre Internet - N9502816R	\$	59.99	
	12/10/2021	Newdegate Medical Centre Internet - N9502816R	\$	50.00	
	12/10/2021	Newdegate Fire Station - 9781 1228	\$	34.95	
	12/10/2021	Group Plan Discount	-\$	85.54	
	12/10/2021	Rounding	-\$	0.03	
	12/10/2021	0457999713 - Trail Camera	\$	15.00	
	12/10/2021	0458004636 - Trail Camera	\$	15.00	
	12/10/2021	0487193712 - NGT Rec Centre Solar backup battery storage	\$	15.00	
	12/10/2021	0487223282 - LG Sports Pav Solar backup battery storage	\$	15.00	
	12/10/2021	0487225597 - LG Sports Pav Solar backup battery storage	\$	15.00	
	12/10/2021	0487234395 - LG Sports Pav Solar backup battery storage	\$	15.00	
EFT22813	27/10/2021	A.P and J.M Keeble		-\$	306.00
	12/10/2021	Lake Grace Visitors Centre September Consignments - The Flora of Tarin Rock Reserve	\$	306.00	
EFT22814	27/10/2021	Albany Irrigation & Drilling		-\$	1,452.00
	19/10/2021	Sprinklers for NGT Rec Grounds	\$	1,452.00	

EFT22815	27/10/2021	Anna Scheepers		-\$	400.00
	09/10/2021	Cleaning of Varley Hall 27/09-08/10/2021	\$	200.00	
	25/10/2021	Cleaning of Varley Hall 11-22/10/2021	\$	200.00	
EFT22816	27/10/2021	Barefoot Clothing Manufacturers		-\$	78.70
	19/10/2021	Shire Polo Shirts for councillors	\$	78.70	
EFT22817	27/10/2021	Best Office Systems		-\$	374.65
	25/10/2021	Photocopier Charges Oct 21	\$	374.65	
EFT22818	27/10/2021	Burgess Rawson Pty Ltd		-\$	260.32
	15/10/2021	Reimbursement Of Water - Ngt Public Toilets Aug to Oct	\$	260.32	
EFT22819	27/10/2021	CB Traffic Solutions Pty Ltd		-\$	935.00
	30/09/2021	Late Night Shopping Road Closure 2021 - Produce Traffic Management Plan	\$	935.00	
EFT22820	27/10/2021	CJD Equipment Pty Ltd		-\$	130.96
	20/10/2021	Parts for PLOD05 L60E Volvo Loader	\$	130.96	
EFT22821	27/10/2021	Casey Australia Tours		-\$	50.00
	21/09/2021	Lake Grace Visitors Centre Stock - Casey Tours Coloured WA Wildflower Guide	\$	50.00	
EFT22822	27/10/2021	DUMBLEYUNG COMMUNITY RESOURCE CENTRE		-\$	35.00
	01/10/2021	Lakes Local Action Group - Adverts in Quack Chat Newsletter	\$	35.00	
EFT22823	27/10/2021	David Wills & Associates		-\$	2,805.00
	14/10/2021	Provision of Consulting Engineering Services for Biddy-Camm Industrial lots road design - 100% Complete	\$	2,805.00	
EFT22824	27/10/2021	Department of Primary Industries and Regional Development		-\$	421.64
	20/10/2021	Recoups - NGT Research Facility - water a/c	\$	421.64	
EFT22825	27/10/2021	Emu Essence Distributors Pty Ltd		-\$	110.82
	13/10/2021	Lake Grace Visitors Centre - September Consignments	\$	110.82	
EFT22826	27/10/2021	Fyfe Logistics Pty Ltd		-\$	3,300.00
	28/09/2021	Freight of HDPE pipes/cement/grader blades	\$	3,300.00	
EFT22827	27/10/2021	Fyfe Transport		-\$	51,345.63
	30/09/2021	Supply and Delivery of aggregate to North Lake Grace Karlgarin Road (RRG) SLK 15.66-19.69	\$	51,345.63	
EFT22828	27/10/2021	Great Southern Fuel Supplies		-\$	468.17
	30/09/2021	Fuel Card Purchases - Lakes Local Action Group	\$	468.17	
EFT22829	27/10/2021	Grillex Pty Ltd		-\$	39,291.45
	08/10/2021	BBQ shelter packs for driver reviver grant	\$	39,291.45	
EFT22830	27/10/2021	Hyden Community Resource Centre		-\$	160.00
	14/07/2021	Lakes Local Action Group - Advertisement	\$	50.00	
	15/09/2021	Lakes Local Action Group - Advertisements	\$	110.00	
EFT22831	27/10/2021	Ipec Pty Ltd		-\$	62.82
	03/10/2021	Freight 24-30/09/2021	\$	51.81	
	10/10/2021	Freight 05/10/2021	\$	11.01	
EFT22832	27/10/2021	Jason Signmakers		-\$	2,099.01
	16/08/2021	Truck signs and posts with caps and bolts	\$	1,324.48	
	19/10/2021	Fogging signage	\$	774.53	
EFT22833	27/10/2021	KONDININ CALENDAR		-\$	60.00
	07/10/2021	Lakes Local Action Group - Advertising	\$	60.00	
EFT22834	27/10/2021	LAKE GRACE GOLF CLUB		-\$	5,000.00
	09/10/2021	Community Grant Funding - Contribution for social and physical wellbeing for community and coaching program	\$	5,000.00	
EFT22835	27/10/2021	Lake Grace CWA		-\$	2,250.00
	11/10/2021	Community Budget Request 2020/21 Contribution - CWA Hall Improvements	\$	2,250.00	
EFT22836	27/10/2021	Lake Grace Community Resource Centre		-\$	27.50
	30/09/2021	Lakes Local Action Group - Advert in the Lakes Link	\$	27.50	
EFT22837	27/10/2021	Lake Grace District High School		-\$	193.76
	25/10/2021	33% Electricity & Water At Lake Grace Community Library/Resource Centre	\$	193.76	

EFT22838	27/10/2021	Lake Grace Engineering		-\$	124.30
	11/10/2021	Drill and tap holes for valve on PTR25 Water Trailer	\$	124.30	
EFT22839	27/10/2021	Lake Grace Saltbush Inn		-\$	144.00
	20/10/2021	Accommodation for EHO - Monday 18 October 2021	\$	144.00	
EFT22840	27/10/2021	Lake Grace Sub Centre St John Ambulance Western Australia Ltd.		-\$	2,301.00
	13/10/2021	Provide first aid training	\$	2,124.00	
	13/10/2021	Provide first aid training	\$	177.00	
EFT22841	27/10/2021	Lake King Agencies		-\$	39.69
	14/10/2021	Diesel for LK Tractor	\$	39.69	
EFT22842	27/10/2021	Local Government Professionals Australia WA Division		-\$	150.00
	14/10/2021	Job Vacancy Advertisement - Swimming Pool Manager	\$	150.00	
EFT22843	27/10/2021	Modus Australia		-\$	25,752.32
	13/10/2021	Final payment of Universal Access toilet for LG all abilities playground	\$	25,752.32	
EFT22844	27/10/2021	Mrs G's Catering		-\$	532.00
	21/10/2021	Catering for OCM - 29 September 2021	\$	532.00	
EFT22845	27/10/2021	Newdegate Grocer And Cafe		-\$	349.70
	08/10/2021	Cleaning supplies for LG Medical Centre & NGT Public Toilets	\$	349.70	
EFT22846	27/10/2021	Newdegate Stock & Trading		-\$	15.95
	03/09/2021	Camlock fitting for NGT Fire Truck	\$	15.95	
EFT22847	27/10/2021	Officeworks		-\$	458.91
	09/09/2021	Various stationary items for Shire Office	\$	452.96	
	15/09/2021	Delivery fee for stationary items	\$	5.95	
EFT22848	27/10/2021	Roamin Enterprises		-\$	21,785.50
	15/10/2021	Drainage works on Lake Biddy Rd SLK 11.50 & Soger Road SLK 3.21 & 1.60	\$	21,785.50	
EFT22849	27/10/2021	SLR Tractors and Machinery Pty Ltd		-\$	5,566.00
	19/10/2021	Supply of new road verge slasher	\$	5,566.00	
EFT22850	27/10/2021	Shire of Kulin		-\$	40.00
	30/09/2021	Lakes Local Action Group - Advert in the Kulin Update	\$	40.00	
EFT22851	27/10/2021	Shire of Lake Grace		-\$	39.95
	12/10/2021	Purchase from the Lake Grace Visitors Centre: The Flora of the Tarin Rock Reserves - Newdegate Library asset	\$	39.95	
EFT22852	27/10/2021	Sigma Chemicals		-\$	6,870.60
	05/10/2021	Chemical for LG Swimming Pool	\$	6,870.60	
EFT22853	27/10/2021	Silverstreak Electrics (WA)		-\$	355.00
	07/10/2021	36 Bennett St - Install new GPO for new instant gas hot water system	\$	355.00	
EFT22854	27/10/2021	Stewart & Heaton Clothing Co		-\$	468.40
	12/10/2021	Bushfire tabards & panels	\$	468.40	
EFT22855	27/10/2021	Synergy Electricity Generation and Retail Corp		-\$	12,407.99
	12/10/2021	118869830 Park Lot 186U Pump Hetherington Way, LK	\$	621.68	
	12/10/2021	156576110 NGT Oval Lot 149 Waddell St NGT	\$	1,192.72	
	12/10/2021	995371470 Lake Grace Oval Lot 1 South Rd LG - Bill Adjustment	-\$	533.28	
	12/10/2021	995371470 Lake Grace Oval Lot 1 South Rd LG	\$	2,424.20	
	12/10/2021	455735630 LK Golf Pavilion Lot 161 Hyden-Lake King Rd	\$	308.66	
	12/10/2021	076250900 LK TV Transmitter Lot 158 Church Ave LK	\$	197.65	
	12/10/2021	867084910 LK Hall Loc 20321 Ravensthorpe Rd LK	\$	1,438.36	
	12/10/2021	624795400 Emergency Services Lot215 The Crossing LK	\$	601.81	
	12/10/2021	546144710 LK Recreation Grnd Loc 20321 U Pump Ravensthorpe Rd LK	\$	447.01	
	12/10/2021	968110430 Town Clock Stubbs St LG	\$	127.67	
	12/10/2021	893222990 LG Swimming Pool Lot 75 Stubbs St LG	\$	1,010.81	
	12/10/2021	336652990 Street Lighting LG 67.2%	\$	2,932.43	
	12/10/2021	336652990 Street Lighting NGT 23.1%	\$	1,008.02	
	12/10/2021	336652990 Street Lighting LK 5.9%	\$	257.46	

	12/10/2021	336652990 Street Lighting Vrl 3.8%	\$	165.82	
	12/10/2021	510645320 Dunn Rock Community Dam 4383 Mallee Rd Magenta (Lot 3019 U A Koornong Rd Ravensthorpe)	\$	206.97	
EFT22856	27/10/2021	WALGA			-\$ 7,630.00
	30/09/2021	2021 WA Local Government Convention - Cr Clarke	\$	1,200.00	
	30/09/2021	2021 WA Local Government Convention - CEO	\$	1,285.00	
	30/09/2021	2021 WA Local Government Convention - Cr Hyde	\$	1,720.00	
	30/09/2021	Head of Agencies Breakfast - Cr Len Armstrong	\$	65.00	
	30/09/2021	Head of Agencies Breakfast - CEO	\$	65.00	
	30/09/2021	2021 WA Local Government Convention - Cr Armstrong	\$	1,425.00	
	30/09/2021	2021 WA Local Government Convention - Cr Chappell	\$	1,685.00	
	05/10/2021	Induction Program for Elected Members - DCEO	\$	240.00	
EFT22857	27/10/2021	WW & Co. Candles			-\$ 29.00
	16/10/2021	Lake Grace Visitors Centre - September Consignments	\$	29.00	
EFT22858	27/10/2021	Wilson's Sign Solutions			-\$ 126.50
	15/10/2021	Supply of name plates for new councillors	\$	126.50	
EFT22859	27/10/2021	Wren Oil			-\$ 16.50
	12/10/2021	Oil Waste Disposal - Annual Admin & Compliance Fees	\$	16.50	
EFT22860	27/10/2021	YMCA WA			-\$ 585.00
	15/09/2021	Lifeguard Requalification for Pool Managers - 19 September	\$	585.00	
		TOTAL EFT			-\$ 906,957.31
36958	18/10/2021	Shire of Lake Grace (Petty Cash)			-\$ 168.60
	30/09/2021	Petty Cash Recoup Sep 21	\$	168.60	
36959	18/10/2021	Water Corporation			-\$ 1,105.84
	12/10/2021	Cemetery at Dumbleyung-Lake Grace Rd Katanning Lot112 Res16771	\$	8.19	
	12/10/2021	Standpipe #8 Jarring South Rd	\$	426.02	
	12/10/2021	Standpipe #6 Burngup Sth Rd	\$	671.63	
		TOTAL CHEQUES			-\$ 1,274.44
DD9720.1	01/10/2021	Westnet Pty Ltd			-\$ 224.85
	01/10/2021	Internet Charges 01/10-01/11/2021	\$	224.85	
DD9721.1	01/10/2021	Exetel Pty Ltd			-\$ 1,375.00
	01/10/2021	Corporate Internet - Monthly Charge On Plan TMLL100 R2 Unlimited 1375	\$	1,375.00	
DD9724.1	13/10/2021	The SD & LM Carruthers Superannuation Fund			-\$ 240.00
	13/10/2021	Superannuation contributions	\$	240.00	
DD9724.2	13/10/2021	Aware Super			-\$ 7,355.48
	13/10/2021	Payroll deductions	\$	520.66	
	13/10/2021	Payroll deductions	\$	442.49	
	13/10/2021	Superannuation contributions	\$	6,392.33	
DD9724.3	13/10/2021	REST Superannuation			-\$ 662.34
	13/10/2021	Payroll deductions	\$	148.69	
	13/10/2021	Superannuation contributions	\$	513.65	
DD9724.4	13/10/2021	North Personal Superannuation			-\$ 141.04
	13/10/2021	Payroll deductions	\$	35.26	
	13/10/2021	Superannuation contributions	\$	105.78	
DD9724.5	13/10/2021	Australian Super Administration			-\$ 492.19
	13/10/2021	Superannuation contributions	\$	421.88	
	13/10/2021	Payroll deductions	\$	70.31	
DD9724.6	13/10/2021	Panorama Super			-\$ 70.52
	13/10/2021	Superannuation contributions	\$	70.52	
DD9724.7	13/10/2021	Prime Super			-\$ 216.99
	13/10/2021	Superannuation contributions	\$	216.99	
DD9724.8	13/10/2021	Hostplus			-\$ 239.69
	13/10/2021	Superannuation contributions	\$	239.69	
DD9737.1	15/10/2021	WA Treasury Corporation			-\$ 32,434.88
	15/10/2021	Principal & interest repayment Loan 203 Redemption - Purchase & Develop Industrial Land	\$	32,434.88	

DD9743.1	21/10/2021	Shire of Lake Grace Credit Card		-\$	7,148.85
	21/10/2021	14/09/21 Meals for CEO, MIS & Councillors in attendance at the Varley 'Progress Assoc Meeting Lake King Tavern Motel Receipt #8142	\$	78.00	
	21/10/2021	19/09/21 4WDL Dinner Gioia on the River Receipt #SP-40 0919134636	\$	3,188.57	
	21/10/2021	19/09/21 Accommodation for CEO and Councillors in attendance at the WALGA Conference Crowne Promenade Perth Receipt #0407	\$	2,416.66	
	21/10/2021	19/09/21 Zoom Subscription from 19 Sep-18 Oct 2021 for Council Zoom Video	\$	23.09	
	21/10/2021	19/09/21 Foreign Transaction Fee for purchase of Zoom Subscription ZOOM.US	\$	0.68	
	21/10/2021	20/09/21 Meals for CEO & Councillors in attendance at the WALGA Conference Crown Perth Market & Co Receipt #999	\$	482.00	
	21/10/2021	21/09/21 Meals for CEO & Councillors in attendance at the WALGA Conference Crown Perth Market & Co Receipt #302	\$	209.00	
	21/10/2021	22/09/21 Costs associated with stay at Crown Promenade Perth for WALGA Conference Crown Promenade Perth Receipt #0407	\$	25.30	
	21/10/2021	22/09/21 Costs associated with stay at Crown Promenade Perth for WALGA Conference Crown Promenade Perth Receipt #0407	\$	725.55	
DD9751.1	27/10/2021	The SD & LM Carruthers Superannuation Fund		-\$	240.00
	27/10/2021	Superannuation contributions	\$	240.00	
DD9751.2	27/10/2021	Australian Super Administration		-\$	492.19
	27/10/2021	Payroll deductions	\$	70.31	
	27/10/2021	Superannuation contributions	\$	421.88	
DD9751.3	27/10/2021	Aware Super		-\$	7,315.59
	27/10/2021	Payroll deductions	\$	521.43	
	27/10/2021	Payroll deductions	\$	442.49	
	27/10/2021	Superannuation contributions	\$	6,351.67	
DD9751.4	27/10/2021	REST Superannuation		-\$	751.38
	27/10/2021	Payroll deductions	\$	153.29	
	27/10/2021	Superannuation contributions	\$	598.09	
DD9751.5	27/10/2021	COLONIAL FIRST STATE FIRST CHOICE PERSONAL SUPER		-\$	452.03
	27/10/2021	Payroll deductions	\$	180.81	
	27/10/2021	Superannuation contributions	\$	271.22	
DD9751.6	27/10/2021	North Personal Superannuation		-\$	141.04
	27/10/2021	Payroll deductions	\$	35.26	
	27/10/2021	Superannuation contributions	\$	105.78	
DD9751.7	27/10/2021	Panorama Super		-\$	152.79
	27/10/2021	Superannuation contributions	\$	152.79	
DD9751.8	27/10/2021	Prime Super		-\$	303.60
	27/10/2021	Superannuation contributions	\$	303.60	
DD9751.9	27/10/2021	Hostplus		-\$	237.57
	27/10/2021	Superannuation contributions	\$	237.57	
DD9755.1	29/10/2021	Australia and New Zealand Banking Group Limited		-\$	1,192.54
	29/10/2021	LLAG - Vehicle Loan Repayment - October	\$	1,192.54	
		TOTAL DIRECT DEBITS		-\$	61,880.56
		TOTAL MUNICIPAL FUND		-\$	970,112.31

SHIRE OF LAKE GRACE
MONTHLY FINANCIAL REPORT
(Containing the Statement of Financial Activity)
For the period ending 31 October 2021

LOCAL GOVERNMENT ACT 1995
LOCAL GOVERNMENT (FINANCIAL MANAGEMENT) REGULATIONS 1996

TABLE OF CONTENTS

Statement of Financial Activity by Program	5
Statement of Financial Activity by Nature or Type	7
Basis of Preparation	8
Note 1 Statement of Financial Activity Information	9
Note 2 Cash and Financial Assets	10
Note 3 Receivables	11
Note 4 Other Current Assets	12
Note 5 Payables	13
Note 6 Rate Revenue	14
Note 7 Disposal of Assets	15
Note 8 Capital Acquisitions	16
Note 9 Borrowings	18
Note 10 Cash Reserves	19
Note 11 Other Current Liabilities	20
Note 12 Operating grants and contributions	21
Note 13 Non operating grants and contributions	22
Note 14 Trust Fund	23
Note 15 Budget Amendments	24
Note 16 Explanation of Material Variances	25

OPERATING ACTIVITIES

OPERATING REVENUE

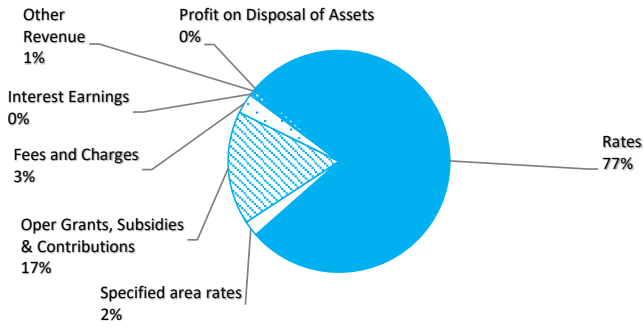

OPERATING EXPENSES

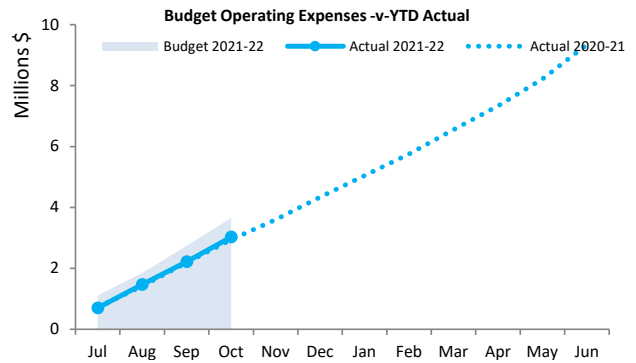
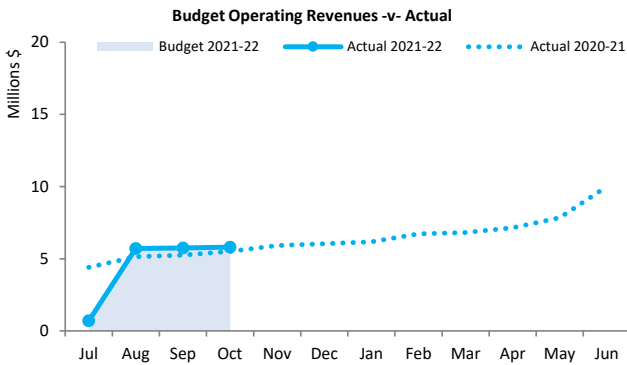
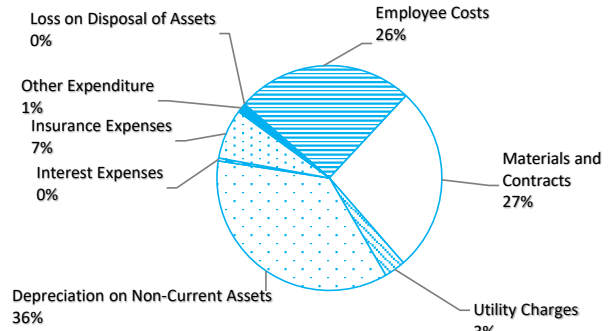

INVESTING ACTIVITIES

CAPITAL REVENUE

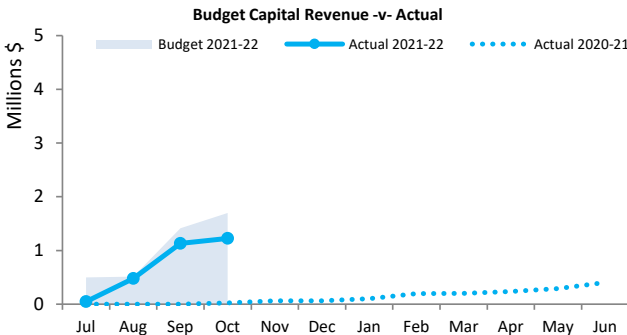

CAPITAL EXPENSES

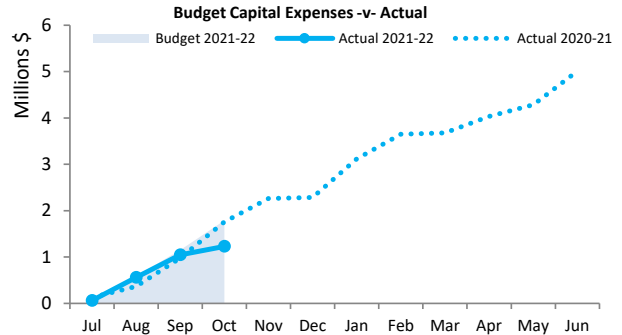

FINANCING ACTIVITIES

BORROWINGS

Principal Repayments

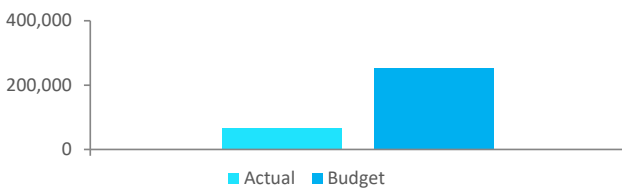

Principal Outstanding

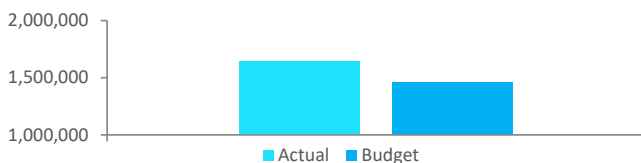

RESERVES

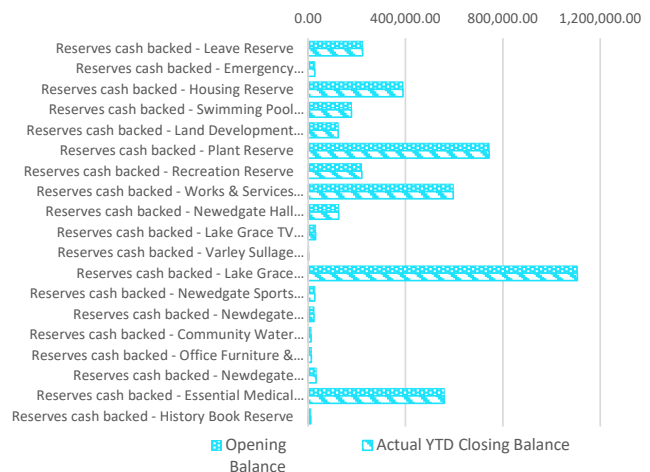

This information is to be read in conjunction with the accompanying Financial Statements and Notes.

Funding surplus / (deficit) Components

Funding surplus / (deficit)				
	Adopted Budget	YTD Budget (a)	YTD Actual (b)	Var. \$ (b)-(a)
Opening	\$5.52 M	\$5.52 M	\$5.68 M	\$0.16 M
Closing	\$0.02 M	\$8.53 M	\$9.43 M	\$0.90 M

Refer to Statement of Financial Activity

Cash and cash equivalents		
	\$	% of total
Unrestricted Cash	\$8.19 M	55.8%
Restricted Cash	\$6.50 M	44.2%

Refer to Note 2 - Cash and Financial Assets

Payables		
	\$	% Outstanding
Trade Payables	\$0.11 M	
0 to 30 Days		99.2%
30 to 90 Days		0.3%
Over 90 Days		0.5%

Refer to Note 5 - Payables

Receivables		
	\$	% Collected
Rates Receivable	\$0.69 M	85.1%
Trade Receivable	\$0.07 M	
30 to 90 Days		5.1%
Over 90 Days		0.7%

Refer to Note 3 - Receivables

Key Operating Activities

Amount attributable to operating activities			
Adopted Budget	YTD Budget (a)	YTD Actual (b)	Var. \$ (b)-(a)
(\$0.73 M)	\$3.13 M	\$3.83 M	\$0.69 M

Refer to Statement of Financial Activity

Rates Revenue		
	\$	% Variance
YTD Actual	\$4.61 M	
YTD Budget	\$4.55 M	1.2%

Refer to Note 6 - Rate Revenue

Operating Grants and Contributions		
	\$	% Variance
YTD Actual	\$0.96 M	
YTD Budget	\$0.92 M	4.0%

Refer to Note 12 - Operating Grants and Contributions

Fees and Charges		
	\$	% Variance
YTD Actual	\$0.17 M	
YTD Budget	\$0.18 M	(7.1%)

Refer to Statement of Financial Activity

Key Investing Activities

Amount attributable to investing activities			
Adopted Budget	YTD Budget (a)	YTD Actual (b)	Var. \$ (b)-(a)
(\$3.74 M)	(\$0.09 M)	(\$0.00 M)	\$0.09 M

Refer to Statement of Financial Activity

Proceeds on sale		
	\$	%
YTD Actual	\$0.00 M	
Adopted Budget	\$0.14 M	(100.0%)

Refer to Note 7 - Disposal of Assets

Asset Acquisition		
	\$	% Spent
YTD Actual	\$1.23 M	
Adopted Budget	\$8.56 M	(85.6%)

Refer to Note 8 - Capital Acquisitions

Capital Grants		
	\$	% Received
YTD Actual	\$1.22 M	
Adopted Budget	\$4.68 M	(73.8%)

Refer to Note 8 - Capital Acquisitions

Key Financing Activities

Amount attributable to financing activities			
Adopted Budget	YTD Budget (a)	YTD Actual (b)	Var. \$ (b)-(a)
(\$1.02 M)	(\$0.03 M)	(\$0.07 M)	(\$0.04 M)

Refer to Statement of Financial Activity

Borrowings	
Principal repayments	\$0.07 M
Interest expense	\$0.01 M
Principal due	\$1.65 M

Refer to Note 9 - Borrowings

Reserves	
Reserves balance	\$4.45 M
Interest earned	\$0.00 M

Refer to Note 10 - Cash Reserves

This information is to be read in conjunction with the accompanying Financial Statements and notes.

Shire operations as disclosed in these financial statements encompass the following service orientated activities/programs.

**PROGRAM NAME AND OBJECTIVES
GOVERNANCE**

To provide a decision making process for the efficient allocation of scarce resources

ACTIVITIES

Includes the activities of Council and the administrative support available to the Council for the provision of governance of the district. Other costs relate to the task of assisting elected members and ratepayers on matters which do not concern specific local government services.

GENERAL PURPOSE FUNDING

To collect revenue to allow for the provision of services

Rates, general purpose government grants and interest revenue

LAW, ORDER, PUBLIC SAFETY

To provide bushfire prevention services and animal control services

Supervision, enforcement of various local laws, fire prevention, emergency services animal control and other aspects of public safety

HEALTH

To provide for an operational framework for good community health in conjunction with the Health Department of WA

Health inspection services in relation to food outlets and their control, pest and noise control and waste disposal compliance and the provision of a Doctor, dental and medical surgeries

EDUCATION AND WELFARE

To provide services for the elderly, children and youth

Maintenance of playgroups and daycare centres. Provision of elderly and youth services

HOUSING

To ensure that adequate housing is available to staff and community

Provision and maintenance of staff housing, aged persons units and community accommodation (Joint Venture and LOGCHOP) units

COMMUNITY AMENITIES

To provide services and infrastructure as required by the community

Rubbish collection services, operation of refuse disposal sites and the Lake Grace sewerage scheme. Administration of the Local Planning Scheme, maintenance of cemeteries and public conveniences

RECREATION AND CULTURE

To establish and effectively manage infrastructure and resources which will help with the social wellbeing of the community

The provision and maintenance of public halls, sports pavilions, recreation grounds Lake Grace swimming pool, parks, gardens and playgrounds. The operation of public libraries in conjunction with the Education Department and other cultural and heritage facilities

TRANSPORT

To provide safe, effective and efficient transport infrastructure to the community

Construction and maintenance of streets, roads, drainage, footpaths and aerodromes
Cleaning of streets, maintenance of street trees, street lighting and works depot.
Provision of Department of Transport licensing services

ECONOMIC SERVICES

To help promote the Shire and improve its economic wellbeing

The regulation and provision of tourism, area promotion, building control, noxious weeds, saleyards and the provision of emergency water supplies

OTHER PROPERTY AND SERVICES

To monitor and control Council's overheads operating accounts

Private works operations, plant repair and operating costs, engineering operating costs

**STATEMENT OF FINANCIAL ACTIVITY
FOR THE PERIOD ENDED 31 OCTOBER 2021**

STATUTORY REPORTING PROGRAMS

	Ref Note	Adopted Budget	YTD Budget (a)	YTD Actual (b)	Var. \$ (b)-(a)	Var. % (b)-(a)/(a)	Var.
		\$	\$	\$	\$	%	
Opening funding surplus / (deficit)	1(c)	5,522,897	5,522,897	5,679,624	156,727	2.84%	
Revenue from operating activities							
Governance		17,550	3,340	3,543	203	6.08%	
General purpose funding - general rates	6	4,423,026	4,422,524	4,476,084	53,560	1.21%	
General purpose funding - other		1,463,088	379,699	407,619	27,920	7.35%	
Law, order and public safety		157,772	54,370	53,489	(881)	(1.62%)	
Health		9,960	3,298	6,135	2,837	86.02%	
Education and welfare		2,000	0	0	0	0.00%	
Housing		18,000	5,997	6,100	103	1.72%	
Community amenities		285,238	265,025	258,901	(6,124)	(2.31%)	
Recreation and culture		59,100	22,014	6,862	(15,152)	(68.83%)	▼
Transport		396,712	347,828	347,980	152	0.04%	
Economic services		387,840	222,762	215,667	(7,095)	(3.19%)	
Other property and services		89,500	28,739	22,624	(6,115)	(21.28%)	▼
		7,309,786	5,755,596	5,805,004	49,408		
Expenditure from operating activities							
Governance		(473,931)	(137,643)	(138,620)	(977)	(0.71%)	
General purpose funding		(152,041)	(49,822)	(45,124)	4,698	9.43%	
Law, order and public safety		(399,853)	(145,894)	(134,922)	10,972	7.52%	
Health		(395,716)	(110,646)	(85,278)	25,368	22.93%	▲
Education and welfare		(78,843)	(27,625)	(27,381)	244	0.88%	
Housing		(234,273)	(87,042)	(49,712)	37,330	42.89%	▲
Community amenities		(1,359,395)	(404,731)	(327,509)	77,222	19.08%	▲
Recreation and culture		(2,706,571)	(929,746)	(725,910)	203,836	21.92%	▲
Transport		(4,237,731)	(1,403,117)	(1,244,738)	158,379	11.29%	▲
Economic services		(1,024,501)	(322,315)	(238,290)	84,025	26.07%	▲
Other property and services		(79,256)	(34,098)	(9,957)	24,141	70.80%	▲
		(11,142,111)	(3,652,679)	(3,027,441)	625,238		
Non-cash amounts excluded from operating activities	1(a)	3,098,135	1,029,580	1,047,721	18,141	1.76%	
Amount attributable to operating activities		(734,190)	3,132,497	3,825,284	692,787		
Investing Activities							
Proceeds from non-operating grants, subsidies and contributions	13	4,677,599	1,697,669	1,224,252	(473,417)	(27.89%)	▼
Proceeds from disposal of assets	7	139,000	0	0	0	0.00%	
Payments for property, plant and equipment and infrastructure	8	(8,557,344)	(1,788,184)	(1,228,769)	559,415	31.28%	▲
Amount attributable to investing activities		(3,740,745)	(90,515)	(4,517)	85,998		
Financing Activities							
Transfer from reserves	10	39,843	39,843	0	(39,843)	(100.00%)	▼
Repayment of debentures	9	(253,822)	(68,109)	(68,109)	0	0.00%	
Transfer to reserves	10	(810,000)	(3,048)	(3,048)	0	0.00%	
Amount attributable to financing activities		(1,023,979)	(31,314)	(71,157)	(39,843)		
Closing funding surplus / (deficit)	1(c)	23,983	8,533,565	9,429,234			

KEY INFORMATION

▲ ▼ Indicates a variance between Year to Date (YTD) Actual and YTD Actual data as per the adopted materiality threshold.

Refer to Note 16 for an explanation of the reasons for the variance.

The material variance adopted by Council for the 2021-22 year is \$5,000 or 10.00% whichever is the greater.

This statement is to be read in conjunction with the accompanying Financial Statements and notes.

KEY TERMS AND DESCRIPTIONS

FOR THE PERIOD ENDED 31 OCTOBER 2021

NATURE OR TYPE DESCRIPTIONS

REVENUE

RATES

All rates levied under the *Local Government Act 1995*. Includes general, differential, specified area rates, minimum rates, interim rates, back rates, ex-gratia rates, less discounts and concessions offered. Exclude administration fees, interest on instalments, interest on arrears, service charges and sewerage rates.

OPERATING GRANTS, SUBSIDIES AND CONTRIBUTIONS

Refers to all amounts received as grants, subsidies and contributions that are not non-operating grants.

NON-OPERATING GRANTS, SUBSIDIES AND CONTRIBUTIONS

Amounts received specifically for the acquisition, construction of new or the upgrading of identifiable non financial assets paid to a local government, irrespective of whether these amounts are received as capital grants, subsidies, contributions or donations.

REVENUE FROM CONTRACTS WITH CUSTOMERS

Revenue from contracts with customers is recognised when the local government satisfies its performance obligations under the contract.

FEES AND CHARGES

Revenues (other than service charges) from the use of facilities and charges made for local government services, sewerage rates, rentals, hire charges, fee for service, photocopying charges, licences, sale of goods or information, fines, penalties and administration fees. Local governments may wish to disclose more detail such as rubbish collection fees, rental of property, fines and penalties, other fees and charges.

SERVICE CHARGES

Service charges imposed under *Division 6 of Part 6 of the Local Government Act 1995*. *Regulation 54 of the Local Government (Financial Management) Regulations 1996* identifies these as television and radio broadcasting, underground electricity and neighbourhood surveillance services. Exclude rubbish removal charges. Interest and other items of a similar nature received from bank and investment accounts, interest on rate instalments, interest on rate arrears and interest on debtors.

INTEREST EARNINGS

Interest and other items of a similar nature received from bank and investment accounts, interest on rate instalments, interest on rate arrears and interest on debtors.

OTHER REVENUE / INCOME

Other revenue, which can not be classified under the above headings, includes dividends, discounts, rebates etc.

PROFIT ON ASSET DISPOSAL

Excess of assets received over the net book value for assets on their disposal.

EXPENSES

EMPLOYEE COSTS

All costs associate with the employment of person such as salaries, wages, allowances, benefits such as vehicle and housing, superannuation, employment expenses, removal expenses, relocation expenses, worker's compensation insurance, training costs, conferences, safety expenses, medical examinations, fringe benefit tax, etc.

MATERIALS AND CONTRACTS

All expenditures on materials, supplies and contracts not classified under other headings. These include supply of goods and materials, legal expenses, consultancy, maintenance agreements, communication expenses, advertising expenses, membership, periodicals, publications, hire expenses, rental, leases, postage and freight etc. Local governments may wish to disclose more detail such as contract services, consultancy, information technology, rental or lease expenditures.

UTILITIES (GAS, ELECTRICITY, WATER, ETC.)

Expenditures made to the respective agencies for the provision of power, gas or water. Exclude expenditures incurred for the reinstatement of roadwork on behalf of these agencies.

INSURANCE

All insurance other than worker's compensation and health benefit insurance included as a cost of employment.

LOSS ON ASSET DISPOSAL

Shortfall between the value of assets received over the net book value for assets on their disposal.

DEPRECIATION ON NON-CURRENT ASSETS

Depreciation expense raised on all classes of assets.

INTEREST EXPENSES

Interest and other costs of finance paid, including costs of finance for loan debentures, overdraft accommodation and refinancing expenses.

OTHER EXPENDITURE

Statutory fees, taxes, allowance for impairment of assets, member's fees or State taxes. Donations and subsidies made to community groups.

**STATEMENT OF FINANCIAL ACTIVITY
FOR THE PERIOD ENDED 31 OCTOBER 2021**

BY NATURE OR TYPE

	Ref Note	Adopted Budget	YTD Budget (a)	YTD Actual (b)	Var. \$ (b)-(a)	Var. % (b)-(a)/(a)	Var.
		\$	\$	\$	\$	%	
Opening funding surplus / (deficit)	1(c)	5,522,897	5,522,897	5,679,624	156,727	2.84%	
Revenue from operating activities							
Rates	6	4,423,026	4,422,524	4,476,084	53,560	1.21%	
Specified area rates	6	130,938	130,938	130,986	48	0.04%	
Operating grants, subsidies and contributions	12	1,960,523	923,099	959,826	36,727	3.98%	
Fees and charges		397,540	183,905	170,761	(13,144)	(7.15%)	
Interest earnings		118,000	39,328	16,005	(23,323)	(59.30%)	▼
Other revenue		256,547	55,802	51,343	(4,459)	(7.99%)	
Profit on disposal of assets	7	23,212	0	0	0	0.00%	
		7,309,786	5,755,596	5,805,005	49,409		
Expenditure from operating activities							
Employee costs		(2,753,070)	(888,176)	(773,332)	114,844	12.93%	▲
Materials and contracts		(4,438,195)	(1,365,576)	(807,032)	558,544	40.90%	▲
Utility charges		(344,950)	(110,833)	(92,496)	18,337	16.54%	▲
Depreciation on non-current assets		(3,089,216)	(1,029,580)	(1,083,660)	(54,080)	(5.25%)	
Interest expenses		(60,418)	(26,110)	(12,397)	13,713	52.52%	▲
Insurance expenses		(209,984)	(187,726)	(217,936)	(30,210)	(16.09%)	▼
Other expenditure		(214,147)	(44,678)	(40,587)	4,091	9.16%	
Loss on disposal of assets	7	(32,131)	0	0	0	0.00%	
		(11,142,111)	(3,652,679)	(3,027,440)	625,239		
Non-cash amounts excluded from operating activities	1(a)	3,098,135	1,029,580	1,047,721	18,141	1.76%	
Amount attributable to operating activities		(734,190)	3,132,497	3,825,286	692,789		
Investing activities							
Proceeds from non-operating grants, subsidies and contributions	13	4,677,599	1,697,669	1,224,252	(473,417)	(27.89%)	▼
Proceeds from disposal of assets	7	139,000	0	0	0	0.00%	
Payments for property, plant and equipment	8	(8,557,344)	(1,788,184)	(1,228,769)	559,415	31.28%	▲
		(3,740,745)	(90,515)	(4,517)	85,998		
Amount attributable to investing activities		(3,740,745)	(90,515)	(4,517)	85,998		
Financing Activities							
Transfer from reserves	10	39,843	39,843	0	(39,843)	(100.00%)	▼
Repayment of debentures	9	(253,822)	(68,109)	(68,109)	0	0.00%	
Transfer to reserves	10	(810,000)	(3,048)	(3,048)	0	0.00%	
Amount attributable to financing activities		(1,023,979)	(31,314)	(71,157)	(39,843)		
Closing funding surplus / (deficit)	1(c)	23,983	8,533,565	9,429,236			

KEY INFORMATION

▲ ▼ Indicates a variance between Year to Date (YTD) Actual and YTD Actual data as per the adopted materiality threshold.

Refer to Note 16 for an explanation of the reasons for the variance.

This statement is to be read in conjunction with the accompanying Financial Statements and Notes.

BASIS OF PREPARATION

The financial report has been prepared in accordance with Australian Accounting Standards (as they apply to local governments and not-for-profit entities) and interpretations of the Australian Accounting Standards Board, and the *Local Government Act 1995* and accompanying regulations.

The *Local Government Act 1995* and accompanying Regulations take precedence over Australian Accounting Standards where they are inconsistent.

The *Local Government (Financial Management) Regulations 1996* specify that vested land is a right-of-use asset to be measured at cost. All right-of-use assets (other than vested improvements) under zero cost concessionary leases are measured at zero cost rather than at fair value. The exception is vested improvements on concessionary land leases such as roads, buildings or other infrastructure which continue to be reported at fair value, as opposed to the vested land which is measured at zero cost. The measurement of vested improvements at fair value is a departure from AASB 16 which would have required the Shire to measure any vested improvements at zero cost.

Accounting policies which have been adopted in the preparation of this financial report have been consistently applied unless stated otherwise. Except for cash flow and rate setting information, the financial report has been prepared on the accrual basis and is based on historical costs, modified, where applicable, by the measurement at fair value of selected non-current assets, financial assets and liabilities.

THE LOCAL GOVERNMENT REPORTING ENTITY

All funds through which the Shire controls resources to carry on its functions have been included in the financial statements forming part of this financial report.

In the process of reporting on the local government as a single unit, all transactions and balances between those funds (for example, loans and transfers between funds) have been eliminated.

All monies held in the Trust Fund are excluded from the financial statements. A separate statement of those monies appears at Note 14 to these financial statements.

SIGNIFICANT ACCOUNTING POLICES

CRITICAL ACCOUNTING ESTIMATES

The preparation of a financial report in conformity with Australian Accounting Standards requires management to make judgements, estimates and assumptions that effect the application of policies and reported amounts of assets and liabilities, income and expenses.

The estimates and associated assumptions are based on historical experience and various other factors that are believed to be reasonable under the circumstances; the results of which form the basis of making the judgements about carrying values of assets and liabilities that are not readily apparent from other sources. Actual results may differ from these estimates.

GOODS AND SERVICES TAX

Revenues, expenses and assets are recognised net of the amount of GST, except where the amount of GST incurred is not recoverable from the Australian Taxation Office (ATO). Receivables and payables are stated inclusive of GST receivable or payable. The net amount of GST recoverable from, or payable to, the ATO is included with receivables or payables in the statement of financial position. Cash flows are presented on a gross basis. The GST components of cash flows arising from investing or financing activities which are recoverable from, or payable to, the ATO are presented as operating cash flows.

ROUNDING OFF FIGURES

All figures shown in this statement are rounded to the nearest dollar.

PREPARATION TIMING AND REVIEW

Date prepared: All known transactions up to 31 October 2020

(a) Non-cash items excluded from operating activities

The following non-cash revenue and expenditure has been excluded from operating activities within the Statement of Financial Activity in accordance with Financial Management Regulation 32.

	Notes	Adopted Budget	YTD Budget (a)	YTD Actual (b)
Non-cash items excluded from operating activities				
		\$	\$	\$
Adjustments to operating activities				
Less: Profit on asset disposals	7	(23,212)	0	0
Less: Movement in liabilities associated with restricted cash				102
Movement in employee benefit provisions (non-current)				(36,041)
Add: Loss on asset disposals	7	32,131	0	0
Add: Depreciation on assets		3,089,216	1,029,580	1,083,660
Total non-cash items excluded from operating activities		3,098,135	1,029,580	1,047,721

(b) Adjustments to net current assets in the Statement of Financial Activity

The following current assets and liabilities have been excluded from the net current assets used in the Statement of Financial Activity in accordance with *Financial Management Regulation* 32 to agree to the surplus/(deficit) after imposition of general rates.

		Last Year Closing 30 June 2021	This Time Last Year 31 October 2020	Year to Date 31 October 2021
Adjustments to net current assets				
Less: Reserves - restricted cash	10	(4,443,828)	(5,707,365)	(4,446,876)
Less: Municipal restricted cash		(50,073)	(50,072)	(50,072)
Less: Trust - restricted cash		(10,373)		
Add: Borrowings	9	229,865	195,242	161,757
Add: Provisions - employee	11	338,653	231,480	302,612
Total adjustments to net current assets		(3,935,756)	(5,330,715)	(4,032,579)

(c) Net current assets used in the Statement of Financial Activity

Current assets				
Cash and cash equivalents	2	12,383,592	10,249,081	14,684,359
Rates receivables	3	49,489	4,334,989	692,874
Receivables	3	202,260	173,929	68,068
Other current assets	4	81,729	516	13,240
Less: Current liabilities				
Payables	5	(564,665)	(155,853)	(251,815)
Borrowings	9	(229,865)	(195,242)	(161,757)
Contract liabilities	11	(1,968,507)	(447,955)	(1,280,540)
Provisions	11	(338,653)	(231,480)	(302,612)
Less: Total adjustments to net current assets	1(b)	(3,935,756)	(5,330,715)	(4,032,579)
Closing funding surplus / (deficit)		5,679,624	8,393,966	9,429,238

CURRENT AND NON-CURRENT CLASSIFICATION

In the determination of whether an asset or liability is current or non-current, consideration is given to the time when each asset or liability is expected to be settled. Unless otherwise stated assets or liabilities are classified as current if expected to be settled within the next 12 months, being the Council's operational cycle.

Description	Classification	Unrestricted	Restricted	Total Cash	Trust	Institution	Interest Rate	Maturity Date
		\$	\$	\$				
Cash on hand								
Municipal Bank account	Cash and cash equivalents	8,186,912		8,186,912		Bankwest	0.10%	Nil
Term deposit - Municipal Bank account	Cash and cash equivalents	0	1,000,000	1,000,000		Bankwest	0.33%	26/11/2021
Term deposit - Municipal Bank account	Cash and cash equivalents	0	1,000,000	1,000,000		Bankwest	0.37%	28/02/2022
Petty Cash and Floats	Cash and cash equivalents	500		500		Cash on Hand	Nil	Nil
Reserve Bank Account	Cash and cash equivalents	0	944,140	944,140		Bankwest	0.10%	Nil
Term deposit - Reserve Bank Account	Cash and cash equivalents	0	3,502,735	3,502,735		Bankwest	0.31%	14/12/2021
Restricted LOGCHOP Housing	Cash and cash equivalents	0	44,669	44,669		Bankwest	0.10%	Nil
Rural Town Salinity Program	Cash and cash equivalents	0	5,403	5,403		Bankwest	0.10%	Nil
Trust Fund Cash at Bank	Cash and cash equivalents	0			10,271	Bankwest	N/A	Nil
Total		8,187,412	6,496,947	14,684,359	10,271			
Comprising								
Cash and cash equivalents		8,187,412	6,496,947	14,684,359	10,271			
		8,187,412	6,496,947	14,684,359	10,271			

KEY INFORMATION

Cash and cash equivalents include cash on hand, cash at bank, deposits available on demand with banks and other short term highly liquid investments with original maturities of three months or less that are readily convertible to known amounts of cash and which are subject to an insignificant risk of changes in value and bank overdrafts. Bank overdrafts are reported as short term borrowings in current liabilities in the statement of net current assets.

The local government classifies financial assets at amortised cost if both of the following criteria are met:

- the asset is held within a business model whose objective is to collect the contractual cashflows, and
- the contractual terms give rise to cash flows that are solely payments of principal and interest.

Financial assets at amortised cost held with registered financial institutions are listed in this note other financial assets at amortised cost are provided in Note 4 - Other assets.

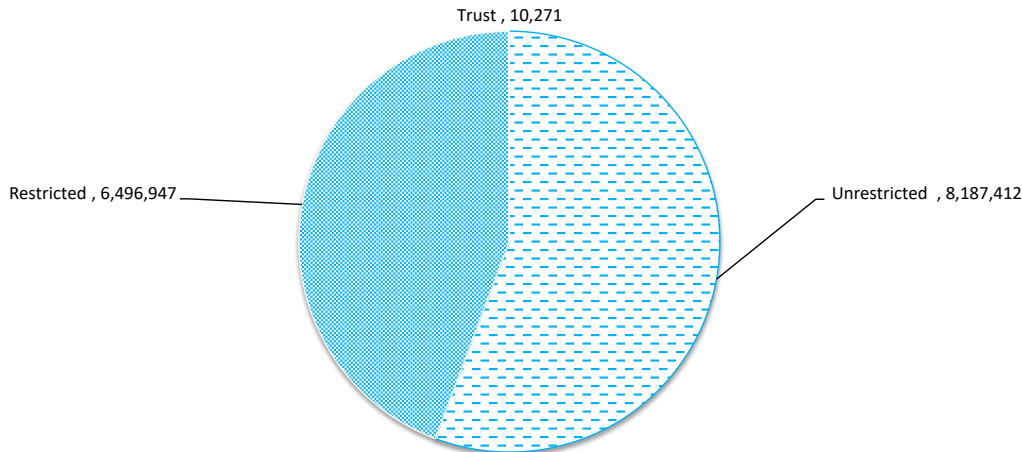

Rates receivable	30 Jun 2021	31 Oct 2021
	\$	\$
Opening arrears previous years	56,644	49,489
Levied this year	4,249,126	4,607,070
Less - collections to date	(4,256,281)	(3,963,685)
Equals current outstanding	49,489	692,874
Net rates collectable	49,489	692,874
% Collected	98.9%	85.1%

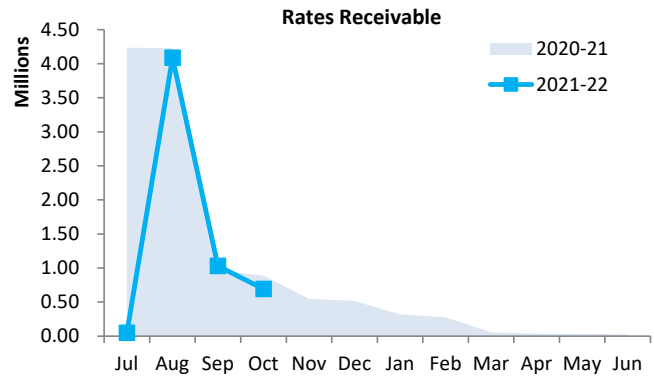

Receivables - general	Credit	Current	30 Days	60 Days	90+ Days	Total
	\$	\$	\$	\$	\$	\$
Receivables - general	(523)	50,418	1,607	1,107	360	52,969
Percentage	(1.0%)	95.2%	3%	2.1%	0.7%	
Balance per trial balance						
Sundry receivable	(523)	50,418	1,607	1,107	360	52,969
ESL Control		15,099				15,099
Total receivables general outstanding						68,068

Amounts shown above include GST (where applicable)

KEY INFORMATION

Trade and other receivables include amounts due from ratepayers for unpaid rates and service charges and other amounts due from third parties for goods sold and services performed in the ordinary course of business. Receivables expected to be collected within 12 months of the end of the reporting period are classified as current assets. All other receivables are classified as non-current assets. Collectability of trade and other receivables is reviewed on an ongoing basis. Debts that are known to be uncollectible are written off when identified. An allowance for impairment of receivables is raised when there is objective evidence that they will not be collectible.

Accounts Receivable (non-rates)

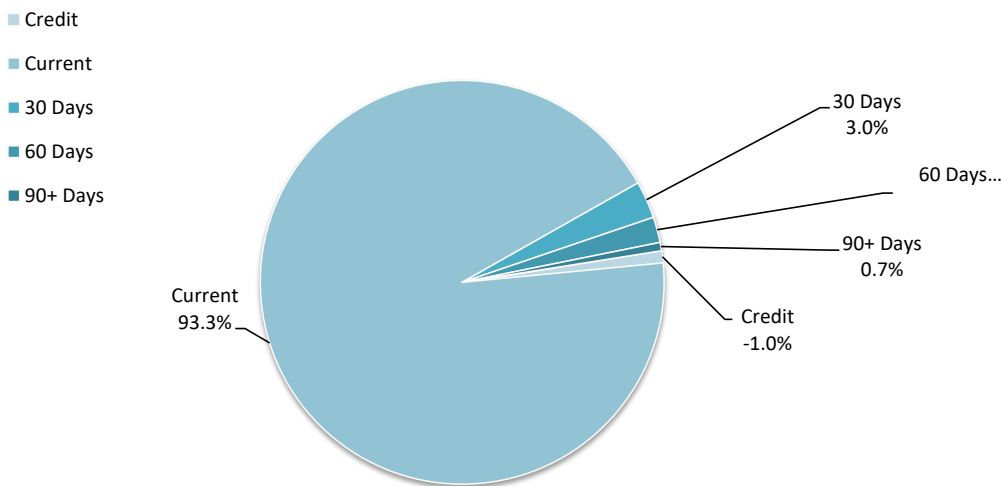

	Opening Balance 1 July 2021	Asset Increase	Asset Reduction	Closing Balance 31 October 2021
	\$	\$	\$	\$
Other current assets				
Inventory				
Stock on Hand	15,745		(2,505)	13,240
Other current assets				
Accrued income	65,984		(65,984)	0
Total other current assets	81,729	0	(68,489)	13,240
Amounts shown above include GST (where applicable)				

KEY INFORMATION

Inventory

Inventories are measured at the lower of cost and net realisable value.

Net realisable value is the estimated selling price in the ordinary course of business less the estimated costs of completion and the estimated costs necessary to make the sale.

Payables - general	Credit	Current	30 Days	60 Days	90+ Days	Total
	\$	\$	\$	\$	\$	\$
Payables - general	0	104,586.43	290.00	0.00	544.00	105,420
Percentage	0%	99.2%	0.3%	0%	0.5%	
Balance per trial balance						
Sundry creditors	0	109,692	290	0	544	110,526
ESL Levied & Prepaid rates		82,098				82,098
Liabilities held for Others - Prepaid Rates		48,920				48,920
Trust Fund Liability		10,271				10,271
Total payables general outstanding						251,815

Amounts shown above include GST (where applicable)

KEY INFORMATION

Trade and other payables represent liabilities for goods and services provided to the Shire that are unpaid and arise when the Shire becomes obliged to make future payments in respect of the purchase of these goods and services. The amounts are unsecured, are recognised as a current liability and are normally paid within 30 days of recognition.

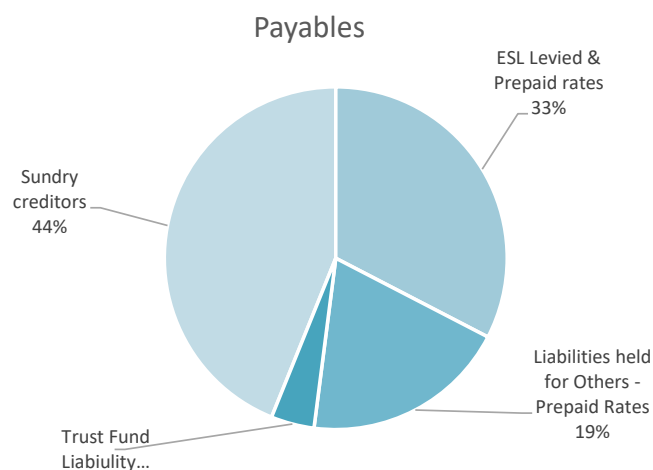
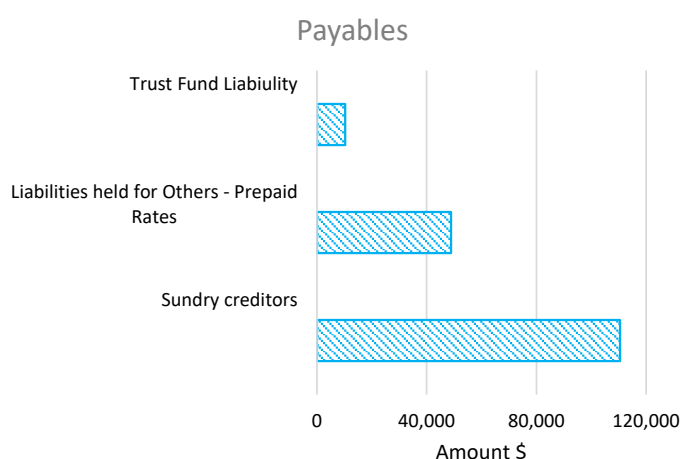
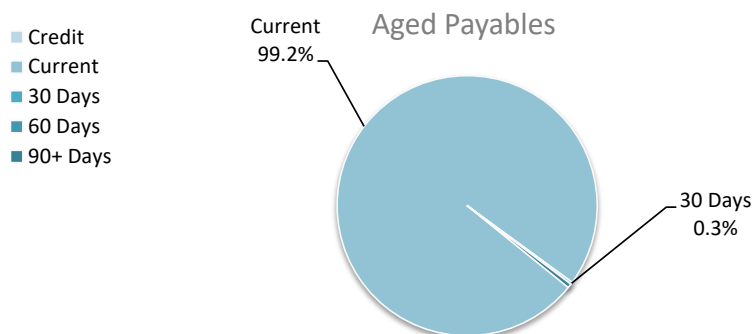

NOTES TO THE STATEMENT OF FINANCIAL ACTIVITY
FOR THE PERIOD ENDED 31 OCTOBER 2021

OPERATING ACTIVITIES
NOTE 6
RATE REVENUE

General rate revenue	Budget							YTD Actual			
	Rate in \$ (cents)	Number of Properties	Rateable Value	Rate Revenue	Interim Rate	Back Rate	Total Revenue	Rate Revenue	Interim Rates	Back Rates	Total Revenue
RATE TYPE				\$	\$	\$	\$	\$	\$	\$	\$
Gross rental value											
General rate revenue - GRV	0.1364	388	4,464,943	609,183	500		609,683	611,170	50,259		661,429
Unimproved value											
General rate revenue - UV	0.0112	557	330,367,521	3,688,223	500		3,688,723	3,689,286	234		3,689,520
Sub-Total		945	334,832,464	4,297,406	1,000	0	4,298,406	4,300,456	50,493	0.00	4,350,949
Minimum payment	Minimum \$										
Gross rental value											
General rate revenue - GRV	505	35		17,675			17,675	17,675			17,675
Unimproved value											
General rate revenue - UV	515	72		37,080			37,080	37,595			37,595
Sub-total		107	0	54,755	0	0	54,755	55,270	0	0	55,270
Amount from general rates							4,353,161				4,406,219
Ex-gratia rates							69,865				69,865
Total general rates							4,423,026				4,476,084
Specified area rates	Rate in \$ (cents)										
Sewergae - GRV	0.045256		2,893,280	130,938			130,938	130,986			130,986
Total specified area rates			2,893,280	130,938	0	0	130,938	130,986	0	0	130,986
Total							4,553,964				4,607,070

KEY INFORMATION

Prepaid rates are, until the taxable event for the rates has occurred, refundable at the request of the ratepayer. Rates received in advance give rise to a financial liability. On 1 July 2020 the prepaid rates were recognised as a financial asset and a related amount was recognised as a financial liability and no income was recognised. When the taxable event occurs the financial liability is extinguished and income recognised for the prepaid rates that have not been refunded.

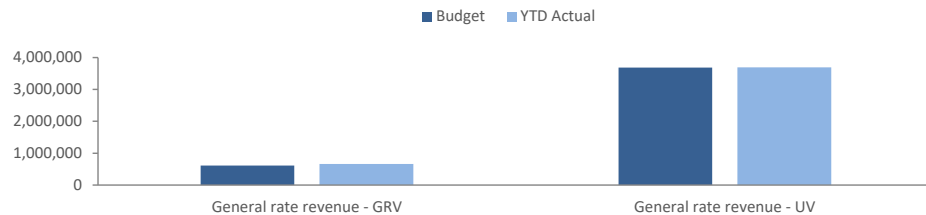

Asset Ref.	Asset description	Budget				YTD Actual			
		Net Book Value	Proceeds	Profit	(Loss)	Net Book Value	Proceeds	Profit	(Loss)
		\$	\$	\$	\$	\$	\$	\$	\$
	Plant and equipment								
	Governance								
1395	Road Verge Slasher (PLM05)	5,109	2,000	0	(3,109)			0	0
123	Mitsubishi Fuso Canter (PTCK 19)	43,887	65,000	21,113	0			0	0
146	Western Star Prime Mover (PTCK 20)	80,764	55,000	0	(25,764)			0	0
1407	Ford Ranger Dual Cab (PLVU 30)	12,901	15,000	2,099	0			0	0
1405	John Deere Z-Track Mower (PJDM01)	5,258	2,000	0	(3,258)			0	0
		147,919	139,000	23,212	(32,131)	0	0	0	0

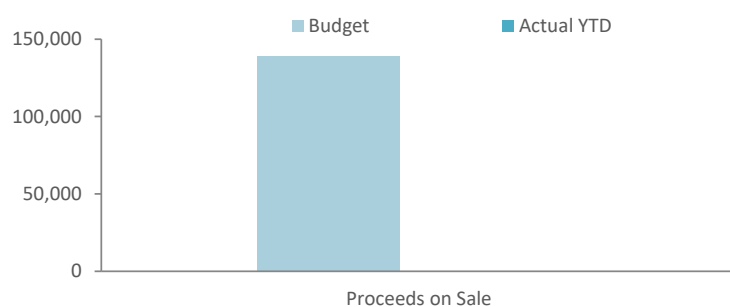

**NOTES TO THE STATEMENT OF FINANCIAL ACTIVITY
FOR THE PERIOD ENDED 31 OCTOBER 2021**

**INVESTING ACTIVITIES
NOTE 8
CAPITAL ACQUISITIONS**

Capital acquisitions	Adopted		YTD Actual	YTD Actual Variance
	Budget	YTD Budget		
	\$	\$	\$	\$
Land	410,000	10,000	10,770	770
Buildings - non-specialised	96,840	32,249	3,073	(29,176)
Buildings - specialised	1,874,735	503,051	389,123	(113,928)
Furniture and equipment	66,300	46,300	0	(46,300)
Plant and equipment	846,000	7,000	5,060	(1,940)
Infrastructure - roads	3,258,569	851,795	540,753	(311,042)
Infrastructure - parks, gardens, recreation facilities	1,679,900	287,790	241,502	(46,288)
Infrastructure - sewerage	75,000	25,000	24,846	(154)
Infrastructure - urban infrastructure	250,000	24,999	13,643	(11,356)
Payments for Capital Acquisitions	8,557,344	1,788,184	1,228,769	(559,415)
Total Capital Acquisitions	8,557,344	1,788,184	1,228,769	(559,415)
Capital Acquisitions Funded By:				
	\$	\$	\$	\$
Capital grants and contributions	4,677,599	1,697,669	1,224,252	(473,417)
Other (disposals & C/Fwd)	139,000	0	0	0
Cash backed reserves				
Reserves cash backed - Newdegate Centenary Reserve	32,343		0	0
Reserves cash backed - Essential Medical Reserve	7,500		0	0
Contribution - operations	3,700,902	90,515	4,517	(85,998)
Capital funding total	8,557,344	1,788,184	1,228,769	(559,415)

SIGNIFICANT ACCOUNTING POLICIES

All assets are initially recognised at cost. Cost is determined as the fair value of the assets given as consideration plus costs incidental to the acquisition. For assets acquired at no cost or for nominal consideration, cost is determined as fair value at the date of acquisition. The cost of non-current assets constructed by the local government includes the cost of all materials used in the construction, direct labour on the project and an appropriate proportion of variable and fixed overhead. Certain asset classes may be revalued on a regular basis such that the carrying values are not materially different from fair value. Assets carried at fair value are to be revalued with sufficient regularity to ensure the carrying amount does not differ materially from that determined using fair value at reporting date.

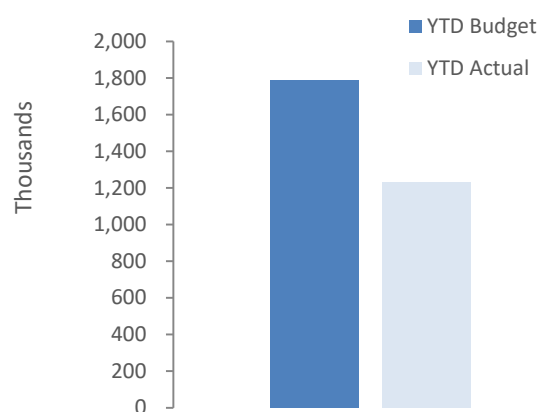

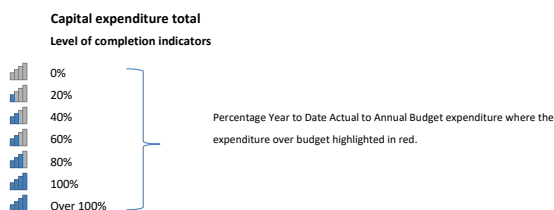

Level of completion indicator, please see table at the end of this note for further detail.

		Adopted			Variance
Account Description		Budget	YTD Budget	YTD Actual	(Under)/Over
Land					
E137350	Lake Grace Industrial Land	410,000	10,000	10,770	770
Buildings - Non Specialised					
E091960 (7750034)	6 Blackbutt Way (Doctor) - Cap Exp	12,000	3,997	0	(3,997)
E091960 (9196034)	5 Banksia Pl Capital	53,081	17,682	0	(17,682)
E091960 (9196084)	54B Bennett St Capital	9,759	3,243	0	(3,243)
E091960 (9196114)	3 Clark Ave Capital	12,000	3,997	0	(3,997)
E091970 (9197134)	10B Gumtree Dr Capital	5,000	1,665	3,073	1,408
E092006 (9200014)	14 Blackbutt Way Capital Exp	5,000	1,665	0	(1,665)
Buildings - Specialised					
E051172 (51171)	Lake King Fire Shed Upgrade	45,000	0	0	0
E077503 (B25CAP)	Lake Grace Medical Centre	76,263	25,411	32,100	6,689
E083101 (8300101)	Lake Grace Day Care Building Upgrade	23,428	7,799	0	(7,799)
E107102 (1071024)	Varley Public Toilets - Cap Exp	32,000	0	0	0
E107102 (NGPTCAP)	Newdegate Public Toilets Cap Ex	7,615	0	0	0
E111007 (LGPHCAP)	Lake Grace Public Hall	38,314	12,760	0	(12,760)
E111007 (LKPHCAP)	Lake King Public Hall	7,000	2,332	1,487	(845)
E111007 (NGPHCAP)	Refurbish Newdegate Hall	100,000	0	0	0
E111007 (VARHCAP)	Varley Town Hall Roof Restoration	30,000	0	0	0
E111007 (VLPHCAP)	Varley Hall - Cap Exp	35,000	0	0	0
E113152 (113014)	Lake King Sports Pavilion Cap Ex	42,287	14,082	0	(14,082)
E113152 (113042)	Unisex Toilets at sporting precincts	88,900	29,629	0	(29,629)
E113152 (113054)	Battery Storage Newdegate & LG Rec Centres	30,000	30,000	32,455	2,455
E113152 (B63CAP)	Newdegate Recreation Centre	60,000	0	0	0
E113152 (CA06)	Newdegate Country Club	942,000	313,970	316,377	2,407
E113152 (CA08)	Painting Lake Grace Pavilion	25,000	4,166	0	(4,166)
E116103 (LKDP)	Lake King Rv Dump Point	25,000	4,166	0	(4,166)
E116103 (LKT1)	Lake King Toilet	60,000	20,000	6,704	(13,296)
E117041 (1170014)	AIM Building Capital	60,347	10,057	0	(10,057)
E117042 (1170084)	RSL Hall	80,000	13,333	0	(13,333)
E121502 (121304)	Lake Grace Depot - Cap Exp	40,998	6,831	0	(6,831)
E126206 (1260061)	LG Airstrip Building upgrade	8,583	2,853	0	(2,853)
E132500 (1325014)	Visitor Centre Improvements	17,000	5,662	0	(5,662)
Furniture & Equipment					
E042541	Upgrade Council Chambers Furniture (table)	20,000	0	0	0
E042561	Implementation Altus Payroll	46,300	46,300	0	(46,300)
Plant & Equipment					
E123059 (PL17CAP)	Isuzu Crew Cab	140,000	0	0	0
E123059 (PL18CAP)	Western Star Prime Mover	296,000	0	0	0
E123059 (PL19CAP)	Ford Ranger Dual Cab	66,000	0	0	0
E123059 (PL20CAP)	Volvo L60E Loader	330,000	0	0	0
E123059 (PL21CAP)	John Deere Z-Track Mower	7,000	0	0	0
E123059 (PL22CAP)	Wilson Road Verge Slasher	7,000	7,000	5,060	(1,940)
Infrastructure - Roads					
E121200	Roadworks Capital Renewal 20/21	2,958,569	801,795	540,609	(261,186)
E121314	Town Street (Boulton St)	300,000	50,000	144	(49,856)
Parks, Gardens, Recreat 113045					
E107259 (113062)	Newdegate cemetery shade & seating	20,000	5,000	5,120	120
E112525 (SGPLCAP)	Solar panels, battery & fence Lake Grace Swimming Pool	70,000	0	0	0
E113175 (113035)	Lighting For Lake Grace Hockey Field Cap Exp	501,000	0	0	0
E113175 (113036)	Lighting For Newdegate Hockey Field Cap Exp	40,000	6,666	0	(6,666)
E113175 (113037)	Lake Grace Football Field Lighting Upgrade Cap Exp	100,000	16,666	0	(16,666)
E113175 (113039)	Solar for Rec Centres & Community Buildings	84,000	27,997	70,909	42,912
E113175 (113043)	Lake King Pavilion Septic Upgrade	30,000	5,000	0	(5,000)
E113175 (113044)	Lake Grace Hockey/Cricket Dugouts	15,000	2,500	0	(2,500)
E113175 (113045)	Varley Town Entry Statement	15,000	5,001	10,192	5,191
E113175 (113046)	Newdegate Jumping Pillow Cap Exp	58,900	19,630	13,841	(5,789)
E113175 (113047)	Community Walk Trails - Lake Grace Cap Exp	30,000	5,000	6,930	1,930
E113175 (113048)	Lake Grace Sporting Complex Entry	100,000	16,666	2,047	(14,619)
E113175 (113051)	Newdegate Adult Gym	30,000	5,000	0	(5,000)
E113175 (113052)	Upgrade Newdegate Walk Trail	50,000	8,333	0	(8,333)
E113175 (113053)	Upgrade Lake King Walk Trail	50,000	8,333	3,266	(5,067)
E113175 (113055)	Jam Patch toilet	4,000	666	371	(295)
E113175 (113059)	Varley Hall paving	10,000	0	0	0
E113175 (1132935)	UAT Lake Grace All Abilities Playground	23,000	23,000	24,630	1,630
E113183 (1131002)	Lake King Sports Dam & Catchment	15,000	0	0	0
E113293 (113201)	Construction Lg Community All Ages Playground	175,000	29,166	0	(29,166)
E113293 (113202)	Lg All Ages Playground Fence	45,000	7,500	0	(7,500)
E121501 (1215011)	Detention Basin/Flood Mitigation Lot 101 Biddy Camm Road	46,000	7,666	0	(7,666)
E132503 (113057)	Install shade & Seating Newdegate Silos	30,000	15,000	14,486	(514)
E132503 (DRU1)	Driver Reviver Upgrade	138,000	73,000	89,709	16,709
Sewerage					
E103163 (1012011)	Sewerage Reuse Lake Grace	75,000	25,000	24,846	(154)
Urban Infrastructure					
E104501 (1040501)	Urban Stormwater Drainage Renewal	40,000	0	0	0
E121312 (121302)	Lake Grace Footpaths Cap Exp	100,000	16,666	12,724	(3,942)
E121312 (121303)	Newdegate Footpath Cap Exp	50,000	8,333	0	(8,333)
E136500 (136006)	Lake Biddy Dam Catchment	60,000	0	919	919
		8,557,344	1,788,184	1,228,769	(559,415)

Repayments - borrowings

Information on borrowings Particulars	Loan No.	1 July 2021	New Loans		Principal Repayments		Principal Outstanding		Interest Repayments	
			Actual	Budget	Actual	Budget	Actual	Budget	Actual	Budget
		\$	\$	\$	\$	\$	\$	\$	\$	\$
Governance										
Office Refurbishment	L181	234,521			8,825.99	17,907	225,695	216,614	3,117	14,954
Housing										
Loan 204 Staff Housing & CEO's Residen	L204	476,044			12,018.24	48,234	464,026	427,810	2,057	7,403
Recreation and culture										
Lake Grace Pool	L173	31,588			7,565.02	15,347	24,023	16,241	488	1,784
LG Sports Pavillion	L182	122,156			8,527.03	17,324	113,629	104,832	1,759	8,358
Newdegate Bowling Club	L193	5,758			2,844.94	5,758	2,913	0	51	262
LG Precinct	L198	69,546			0.00	22,163	69,546	47,383	18	3,420
LK Court Resurfacing	L202	9,519			0.00	9,519	9,519	0	29	241
Transport										
Roadworks & Plant	L196	102,916			0.00	50,487	102,916	52,429	149	4,357
Economic services										
LG Residential Land	L189	118,008			0.00	10,214	118,008	107,794	405	7,817
Purchase & Develop Industrial Land	L203	543,980			28,327.83	56,870	515,652	487,110	4,323	11,822
		1,714,036	0	0	68,109	253,822	1,645,927	1,460,214	12,397	60,418
Total		1,714,036	0	0	68,109	253,822	1,645,927	1,460,214	12,397	60,418
Current borrowings		253,822					161,757			
Non-current borrowings		1,460,214					1,484,170			
		1,714,036					1,645,927			

All debenture repayments were financed by general purpose revenue.

KEY INFORMATION

All loans and borrowings are initially recognised at the fair value of the consideration received less directly attributable transaction costs. After initial recognition, interest-bearing loans and borrowings are subsequently measured at amortised cost using the effective interest method. Fees paid on the establishment of loan facilities that are yield related are included as part of the carrying amount of the loans and borrowings.

Cash backed reserve

Reserve name	Opening Balance	Budget Interest Earned	Actual Interest Earned	Budget Transfers In (+)	Actual Transfers In (+)	Budget Transfers Out (-)	Actual Transfers Out (-)	Budget Closing Balance	Actual YTD Closing Balance
	\$	\$	\$	\$	\$	\$	\$	\$	\$
Reserves cash backed - Leave Reserve	224,214.00	1,678	154	110,000				335,892	224,368
Reserves cash backed - Emergency Services Reserve	27,295.00	204	19					27,499	27,314
Reserves cash backed - Housing Reserve	389,490.00	3,068	267	200,000				592,558	389,757
Reserves cash backed - Swimming Pool Reserve	178,222.00	51,706	122					229,928	178,344
Reserves cash backed - Land Development Reserve	123,493.00	924	85					124,417	123,578
Reserves cash backed - Plant Reserve	743,297.00	10,026	510	350,000				1,103,323	743,807
Reserves cash backed - Recreation Reserve	219,975.00	1,638	151					221,613	220,126
Reserves cash backed - Works & Services Reserve	596,065.00	4,458	409					600,523	596,474
Reserves cash backed - Newedgate Hall Reserve	125,879.00	942	86					126,821	125,965
Reserves cash backed - Lake Grace TV Reserve	30,273.00	247	21					30,520	30,294
Reserves cash backed - Varley Sullage Reserve	1,674.00	13	1					1,687	1,675
Reserves cash backed - Lake Grace Sewerage Reserve	1,105,466.00	8,614	758	60,000				1,174,080	1,106,224
Reserves cash backed - Newedgate Sports Dam Reserve	26,896.00	201	18					27,097	26,914
Reserves cash backed - Newdegate Stadium Floor Reserve	24,267.00	182	17					24,449	24,284
Reserves cash backed - Community Water Supplies Reserve	12,044.00	90	8					12,134	12,052
Reserves cash backed - Office Furniture & Equipment Reserve	13,381.00	100	9					13,481	13,390
Reserves cash backed - Newdegate Centenary Reserve	32,322.00	242	22			(32,343)		221	32,344
Reserves cash backed - Essential Medical Reserve	559,058.00	5,589	383			(7,500)		557,147	559,441
Reserves cash backed - History Book Reserve	10,517.00	78	7					10,595	10,524
	4,443,828	90,000	3,048	720,000	0	(39,843)	0	5,213,985	4,446,876

KEY INFORMATION

	Note	Opening Balance 1 July 2021	Liability transferred from/(to) non current	Liability Increase	Liability Reduction	Closing Balance 31 October 2021
		\$		\$	\$	\$
Other current liabilities						
Other liabilities						
- Contract liabilities		1,954,792	0	150,000.00	(824,252.00)	1,280,540
- Income Received in Advance		13,715	0		(13,715)	0
Total other liabilities		1,968,507	0	150,000	(837,967)	1,280,540
Provisions						
Provision for annual leave		221,178			(26,577)	194,601
Provision for long service leave		117,475	0		(9,464)	108,011
Total Provisions		338,653	0	0	(36,041)	302,612
Total other current liabilities		2,307,160	0	150,000	(874,008)	1,583,152
Amounts shown above include GST (where applicable)						

A breakdown of contract liabilities and associated movements is provided on the following pages at Note 12

KEY INFORMATION

Provisions

Provisions are recognised when the Shire has a present legal or constructive obligation, as a result of past events, for which it is probable that an outflow of economic benefits will result and that outflow can be reliably measured.

Provisions are measured using the best estimate of the amounts required to settle the obligation at the end of the reporting period.

Employee benefits

Short-term employee benefits

Provision is made for the Shire's obligations for short-term employee benefits. Short-term employee benefits are benefits (other than termination benefits) that are expected to be settled wholly before 12 months after the end of the annual reporting period in which the employees render the related service, including wages, salaries and sick leave. Short-term employee benefits are measured at the (undiscounted) amounts expected to be paid when the obligation is settled.

The Shire's obligations for short-term employee benefits such as wages, salaries and sick leave are recognised as a part of current trade and other payables in the calculation of net current assets.

Other long-term employee benefits

The Shire's obligations for employees' annual leave and long service leave entitlements are recognised as provisions in the statement of financial position.

Long-term employee benefits are measured at the present value of the expected future payments to be made to employees. Expected future payments incorporate anticipated future wage and salary levels, durations of service and employee departures and are discounted at rates determined by reference to market yields at the end of the reporting period on government bonds that have maturity dates that approximate the terms of the obligations. Any remeasurements for changes in assumptions of obligations for other long-term employee benefits are recognised in profit or loss in the periods in which the changes occur. The Shire's obligations for long-term employee benefits are presented as non-current provisions in its statement of financial position, except where the Shire does not have an unconditional right to defer settlement for at least 12 months after the end of the reporting period, in which case the obligations are presented as current provisions.

Contract liabilities

An entity's obligation to transfer goods or services to a customer for which the entity has received consideration (or the amount is due) from the customer. Grants to acquire or construct recognisable non-financial assets to identified specifications be constructed to be controlled by the Shire are recognised as a liability until such time as the Shire satisfies its obligations under the agreement.

Provider	Unspent operating grant, subsidies and contributions liability					Operating grants, subsidies and contributions revenue		
	Liability	Increase in Liability	Decrease in Liability	Liability	Current Liability	Adopted Budget	YTD	YTD
	1 July 2021		(As revenue)	31 Oct 2021	31 Oct 2021	Revenue	Budget	Revenue
	\$	\$	\$	\$	\$	\$	\$	\$
Operating grants and subsidies								
General purpose funding								
Grants Commisiion - General				0		729,422	182,356	217,067
Grants Commission Roads				0		598,361	149,590	164,699
Law, order, public safety								
Grant - DFES LGGS Operating				0		58,840	29,420	27,430
Transport								
Direct Grant - MRWA				0		339,000	339,000	339,138
Economic services								
Skeleton Weed Programm Grant				0		205,000	205,000	205,000
	0	0	0	0	0	1,930,623	905,366	953,333
Operating contributions								
General purpose funding								
ESL Administration Fee				0		4,000	4,000	4,000
Education and welfare								
Grants - Senior Activities				0		1,000	0	0
Grants - Youth Activities				0		1,000	0	0
Recreation and culture								
Lake Grace Rec Council Affiliation Fees				0		13,000	13,000	2,200
Contributions - Other Culture				0		1,000	0	0
Lake King Pavilion / Oval - Hire Fees				0		500	500	0
Transport								
Contributions - Street Lighting				0		8,000	0	0
Economic services								
AIM Contributions				0		1,400	233	293
	0	0	0	0	0	29,900	17,733	6,493
TOTALS	0	0	0	0	0	1,960,523	923,099	959,826

Provider	Unspent non operating grants, subsidies and contributions liability					Non operating grants, subsidies and contributions revenue		
	Liability	Increase in Liability	Decrease in Liability	Liability	Current Liability	Adopted Budget	YTD	YTD
	1 July 2021		(As revenue)	31 Oct 2021	31 Oct 2021	Revenue	Budget	Revenue
	\$	\$	\$	\$	\$	\$	\$	\$
Non-operating grants and subsidies								
Law, order, public safety								
Grant - DFES Cap Exp				0		25,000	25,000	0
Community amenities								
Drought & Community	65,083		(23,946)	41,136	41,136	90,000	0	23,946
Local Roads & Community Program	10,000		(5,120)	4,880	4,880	20,000	0	5,120
Recreation and culture								
Drought & Community	680,325		(336,358)	343,967	343,967	764,896	447,432	336,358
Local Roads & Community Program	471,916		(98,668)	373,247	373,247	1,167,900	389,261	98,668
Transport								
RADS Grant - Lake Grace Airstrip Light Upgrade				0	0	61,500	0	0
Roads to Recovery	574,715		(255,964)	318,751	318,751	1,488,303	243,976	255,964
Regional Road Group		150,000	0	150,000	150,000	492,000	123,000	0
Economic services								
Local Roads & Community Grant	15,000		(14,486)	514	514	30,000	15,000	14,486
Driver Reviver Upgrade Grant	137,754		(89,709)	48,045	48,045	138,000	54,000	89,709
	1,954,792	150,000	(824,252)	1,280,540	1,280,540	4,277,599	1,297,669	824,252
Non-operating contributions								
Recreation and culture								
Newdegate Community Contribution				0		400,000	400,000	400,000
	0	0	0	0	0	400,000	400,000	400,000
TOTALS	1,954,792	150,000	(824,252)	1,280,540	1,280,540	4,677,599	1,697,669	1,224,252

**NOTES TO THE STATEMENT OF FINANCIAL ACTIVITY
FOR THE PERIOD ENDED 31 OCTOBER 2021**

**NOTE 14
TRUST FUND**

Funds held at balance date which are required by legislation to be credited to the trust fund and which are not included in the financial statements are as follows:

Description	Opening Balance 1 July 2021	Amount Received	Amount Paid	Closing Balance 31 Oct 2021
	\$	\$	\$	\$
Standpipe bonds	10,373		(102)	10,271
	10,373	0	(102)	10,271

**NOTES TO THE STATEMENT OF FINANCIAL ACTIVITY
FOR THE PERIOD ENDED 31 OCTOBER 2021**

**NOTE 15
BUDGET AMENDMENTS**

Amendments to original budget since budget adoption. Surplus/(Deficit)

GL Code	Description	Council Resolution	Classification	Non Cash Adjustment	Increase in Available Cash	Decrease in Available Cash	Amended Budget Running Balance
				\$	\$	\$	\$
	Budget adoption		Opening surplus				23,983
I138100	Grants & Subsidies	N/A	Operating Revenue			(205,000)	(181,017)
I131230	Grant - Skeleton Weed Programm	N/A	Operating Revenue		205,000		23,983
1012011	Sewerage Reuse Lake Grace	N/A	Capital Expenses			(15,000)	8,983
113045	Varley Entry Statement Cap Exp	N/A	Capital Expenses		15,000		23,983
I139101	Merchandise Sales MUN	13451	Operating Revenue		14,000		37,983
I139104	AIM Contributions	13451	Operating Revenue		1,400		39,383
E139110	Stock Purchases	13451	Operating Expenses			(11,000)	28,383
E139112	Stationery and Consumables	13451	Operating Expenses			(1,000)	27,383
E139114	Volunteer Functions	13451	Operating Expenses			(2,000)	25,383
E139115	AIM Souvenirs	13451	Operating Expenses			(1,400)	23,983
95001	Lakes Village Garden Maintenance	13479	Operating Expenses			(4,396)	19,587
113003	Lake Grace Rec Ground Maintenance	13479	Operating Expenses		4,396		23,983
1040101	Urban Stormwater Drainage	13481	Operating Expenses			(70,000)	(46,017)
122505	Drainage	13481	Operating Expenses		70,000		23,983
B25CAP	Lake Grace Medical Centre	13482	Capital Expenses			(7,500)	16,483
	Transfer from from the Essential Medical Services Reserve	13482			7,500		23,983
E042286	Newdegate Centenary Celebrations	13489	Operating Expenses			(32,343)	(8,360)
	Transfer from from the Newdegate 100 Year Centenary Reserve	13489			32,343		23,983
				0	349,639	(349,639)	0

**NOTES TO THE STATEMENT OF FINANCIAL ACTIVITY
FOR THE PERIOD ENDED 31 OCTOBER 2021**

**NOTE 16
EXPLANATION OF MATERIAL VARIANCES**

The material variance thresholds are adopted annually by Council as an indicator of whether the actual expenditure or revenue varies from the year to date Actual materially.

The material variance adopted by Council for the 2021-22 year is \$5,000 or 10.00% whichever is the greater.

Reporting Program	Var. \$	Var. %	Explanation of positive variances		Explanation of negative variances	
			Timing	Permanent	Timing	Permanent
	\$	%				
Revenue from operating activities						
Recreation and culture	(15,152)	(68.83%) ▼			Hall And Equipment Hire Fees are below budget	Affiliation Fees and Hall & Equipment Hire Fees are below budget
Other property and services	(6,115)	(21.28%) ▼			Private Works Income below budget	
Expenditure from operating activities						
Health	25,368	22.93% ▲				
					Contract Environmental Health Officer, Doctors Residence and Medical centres Building Mtc under budget	
Housing	37,330	42.89% ▲			Staff Housing Mtc is under budget	
Community amenities	77,222	19.08% ▲			LG Sewerage and Cemeteries Maintenance under budget	
Recreation and culture	203,836	21.92% ▲			Building Maintenance of majority Cultural Buildings down	
Transport	158,379	11.29% ▲			Rural Roads and Town Street Mtc is under budget	
Economic services	84,025	26.07% ▲			Skelton Weed Project Expenses, Tourism Promotion & Standpipe Expenses are down	No Contract Building Surveyor Exp in 21/22
Other property and services	24,141	70.80% ▲			Superannuation - Council Contribution & Plant - Parts And Repairs below budget	
Investing activities						
Proceeds from non-operating grants, subsidies and contributions	(473,417)	(27.89%) ▼				Bulk of "Local Roads & Community" and "Drought & Community" projects are not yet initiated/finalised, funds will be recognised later in financial year
Payments for property, plant and equipment and infrastructure	559,415	31.28% ▲			Many of the projects have not been initiated as yet (65%) or in early stage of compilation	
Financing activities						
Transfer from reserves	(39,843)	(100.00%) ▼				To be transferred on completion of works

Municipal Bank Statement

Summary:

G/L Account (as at Month End)
1A0011010 Municipal Bank Account MUN

Statement No 35
Statement Date 30/10/2021

Opening Balance	10,845,584.87
Deposits	\$493,693.80
Payments	-970,112.31
Fees	-64,627.70
Adjustments	-117,626.69
Closing Balance	10,186,911.97

Opening Balance	10,845,745.39
<u>Reconciled Items</u>	
Deposits	492,386.88
Payments	-925,242.47
Fees	-64,627.70
Adjustments	-117,126.69
Closing Balance	10,185,902.30

The Bank Statement balances to the General Ledger

<u>Unreconciled Items</u>	
Deposits	1,009.67
Payments	0.00
Fees	0.00
Adjustments	0.00
Unreconciled Closing Balance	1,009.67
Total - To agree with GL	10,186,911.97

Municipal Account - Reconciliation to 31/10/2021

G/L Account (as at Month End):

Fees:

Dept of Transport	-\$62,989.25
Bank Fees	-\$2,328.26
LESS: Interest Received	\$689.81
	<u><u>-\$64,627.70</u></u>

Adjustments

Payroll	-\$116,126.69
Payroll Rent Deduction	-\$500.00
Returned Bond payment	-\$1,000.00
	<u><u>-\$117,626.69</u></u>

Unreconciled Items:

	<u><u>-\$1,009.67</u></u>
--	---------------------------

Outstanding Deposits

Cash/Chq 28/10/2021	-\$1,009.67
	<u><u>-\$1,009.67</u></u>

ENTERED

By Victoria Fasano - FO at 7:00 pm, Nov 01, 2021

APPROVED

By CEO - Alan George at 8:11 am, Nov 02, 2021

Included only in GL Account Adjustments (left part), shown as Payments in the Statement (right part)

Trust Bank Statement

Summary:

G/L Account (as at Month End)
 1A0013050 Trust Fund Cash At Bank MUN

Statement No 35
 Statement Date 31/10/2021

Opening Balance	10,270.90
Deposits	\$0.00
Payments	0.00
Fees	0.00
Adjustments	0.00
Closing Balance	10,270.90

Opening Balance	10,321.90
<u>Reconciled Items</u>	
Deposits	0.00
Payments	0.00
Fees	0.00
Adjustments	0.00
Closing Balance	10,321.90

Unreconciled Items

The Bank Statement balances to the General Ledger

Deposits	0.00
Payments	-51.00
Fees	0.00
Adjustments	0.00
Unreconciled Closing Balance	-51.00
Total - To agree with GL	10,270.90

Unreconciled Items:

Type	Date	Reference	Amount	Description
CSH	25/08/2021	1539	51.00	JDC Drilling Pty
Total:			51.00	

ENTERED

By Victoria Fasano - FO at 10:58 am, Nov 01, 2021

APPROVED

By CEO - Alan George at 11:28 am, Nov 01, 2021

Shire of Lake Grace



Reserve Bank Statement

Reserve No	Reserve Account Name		Balance
11	Emergency Services Reserve Bank	\$	27,313.39
12	Housing Reserve Bank	\$	389,756.86
13	Swimming Pool (Lake Grace) Reserve Bank	\$	178,343.86
14	Land Development Reserve Bank	\$	123,578.32
15	Leave Reserve Bank	\$	224,367.41
16	Plant Replacement Reserve Bank	\$	743,807.14
17	Recreation Reserve Bank	\$	220,126.46
18	Works & Services Reserve Bank	\$	596,473.92
19	Newdegate Hall Reserve Bank	\$	125,965.04
20	Lake Grace TV Reserve Bank	\$	30,293.80
23	Varley Sullage Reserve Bank	\$	1,675.62
31	Lake Grace Sewerage Scheme Reserve Bank	\$	1,106,223.86
35	Newdegate Sports Dam Reserve Bank	\$	26,914.14
36	Newdegate Stadium Floor Reserve Bank	\$	24,283.49
37	Community Water Supply Reserve Bank	\$	12,051.92
40	Office Furniture & Equipment Reserve Bank	\$	13,389.73
41	Newdegate 100 Year Centenary Reserve Bank	\$	32,344.11
42	History Book Reserve Bank	\$	10,523.91
43	Essential Medical Services Reserve Bank	\$	559,441.85
0		0	\$ 4,446,874.83

\$4,446,874.83

ENTERED

By Victoria Fasano - FO at 4:20 pm, Nov 01, 2021

Bank Balance

31/10/2021

Term Deposit	\$3,502,734.80
Reserve Acc	\$944,140.03
	<u>\$4,446,874.83</u>

Variance \$0.00

APPROVED

By CEO - Alan George at 4:53 pm, Nov 01, 2021

Reserves Fund Statement