



Shire of Lake Grace

24 May 2023

Ordinary Council Meeting

INFORMATION BULLETIN

ITEM 16.1 - ATTACHMENTS

TABLE OF CONTENTS

REPORTS:

Title of Report	No of Pages
Infrastructure Services Report – April 2023	8
Lake King Library Report and Statistics – April 2023	2

EXTERNAL ORGANISATIONS

WALGA Central Country Zone Minutes – 14 April 2023	46
Lake Grace Roadwise Committee Minutes 11 May 2023	2

CIRCULARS, MEDIA RELEASES & NEWSLETTERS:

Nil – Emailed to Councillors



Information Bulletin
Infrastructure Services Report

Shire of Lake Grace

Prepared for the May 2023 Ordinary Council Meeting
presenting information to the end of April 2023

Road Maintenance Grading

For the month of April 2023

Lake Grace Area		Newdegate Area		Lake King-Varley Area	
Road Name	Graded (km)	Road Name	Graded (km)	Road Name	Graded (km)
Argent Rd	6.90	Ardler Rd	10.78	Carstairs Rd	1.20
Burngup Rd	1.90	Green Rd	7.30	Holt Rock South Rd	11.60
Green Rd	7.30	Magenta Rd	21.28	Long Creek Rd	10.89
MacNamara Rd	5.98	Morgan Rd	2.65	Magdhaba Tr	5.60
		Old Ravensthorpe Rd	19.09	Milstead Rd	6.20
		Tuck Rd	16.11	Old Newdegate Rd	37.99
				Tarco Rd	15.81
Subtotal	22.08	Subtotal	77.21	Subtotal	89.29

2022/23 Year-To-Date Grading by Month

Year	Month	<i>Lake Grace Area (km)</i>	<i>Newdegate Area (km)</i>	<i>Lake King-Varley Area (km)</i>	Monthly Subtotal
2022	July	54.94	83.19	93.13	231.26
	August	49.65	80.41	54.70	184.76
	September	6.02	77.52	63.46	147.00
	October	0.00	32.43	90.57	123.00
	November	43.89	107.97	137.06	288.92
	December	113.19	100.51	161.76	375.46
2023	January	0.00	96.89	85.76	182.65
	February	0.00	155.77	144.34	300.11
	March	137.09	36.91	154.87	328.87
	April	22.08	77.21	89.29	188.58
	May				
	June				
	<u>To-Date</u>	<u>426.86</u>	<u>848.81</u>	<u>1,074.94</u>	<u>2,350.61</u>

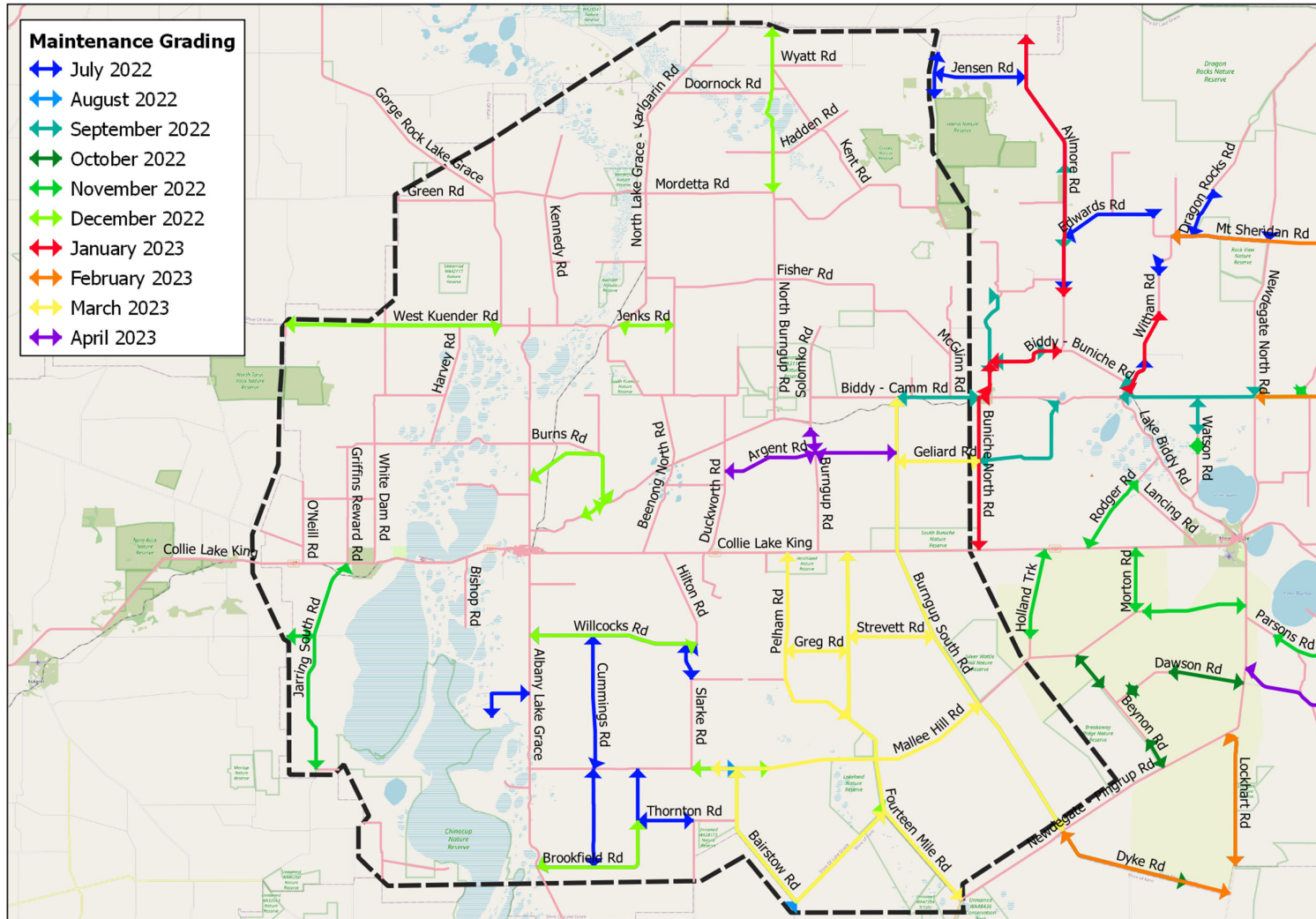

Monthly maintenance grading – Lake Grace area

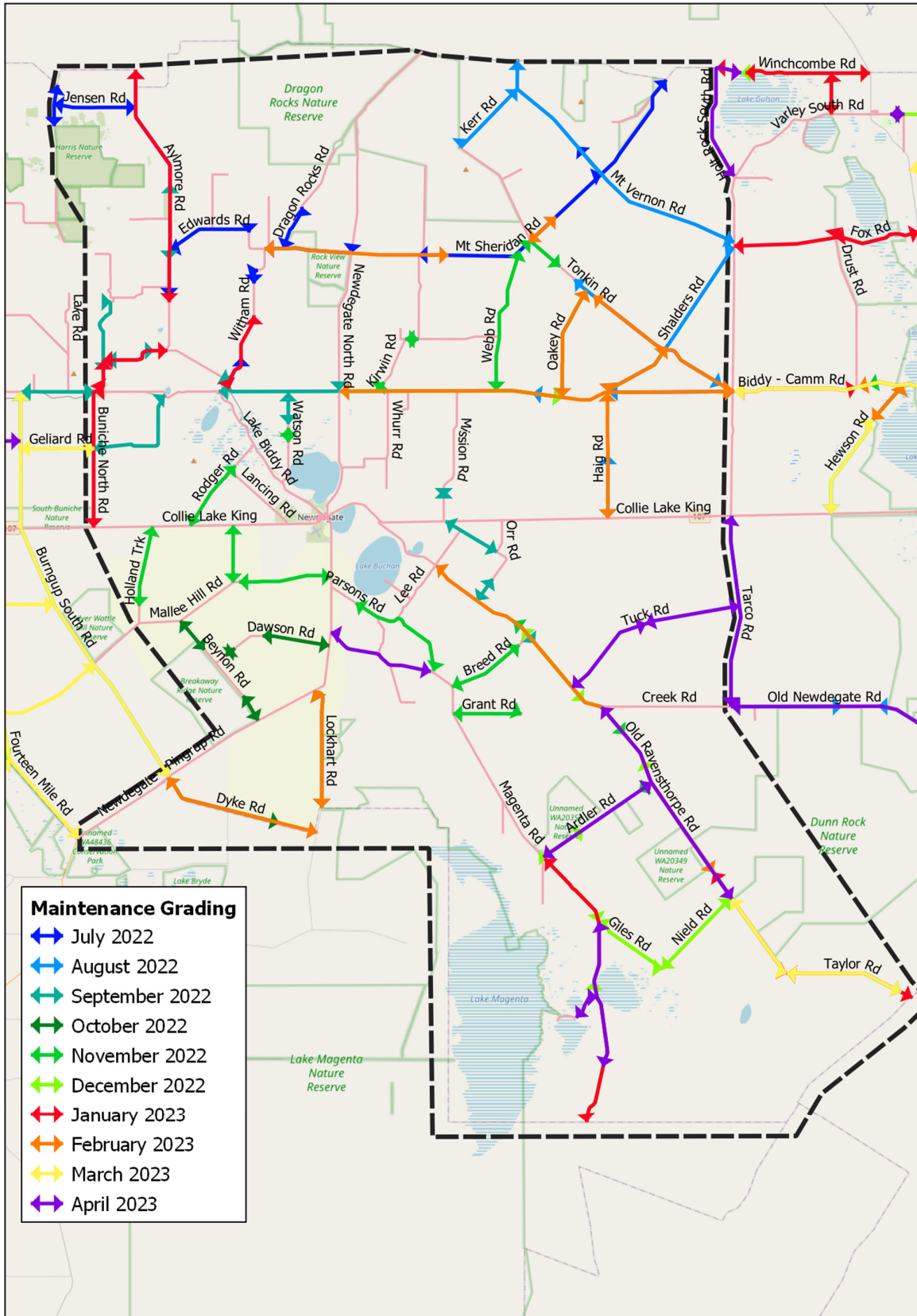

Monthly maintenance grading – Newdegate area

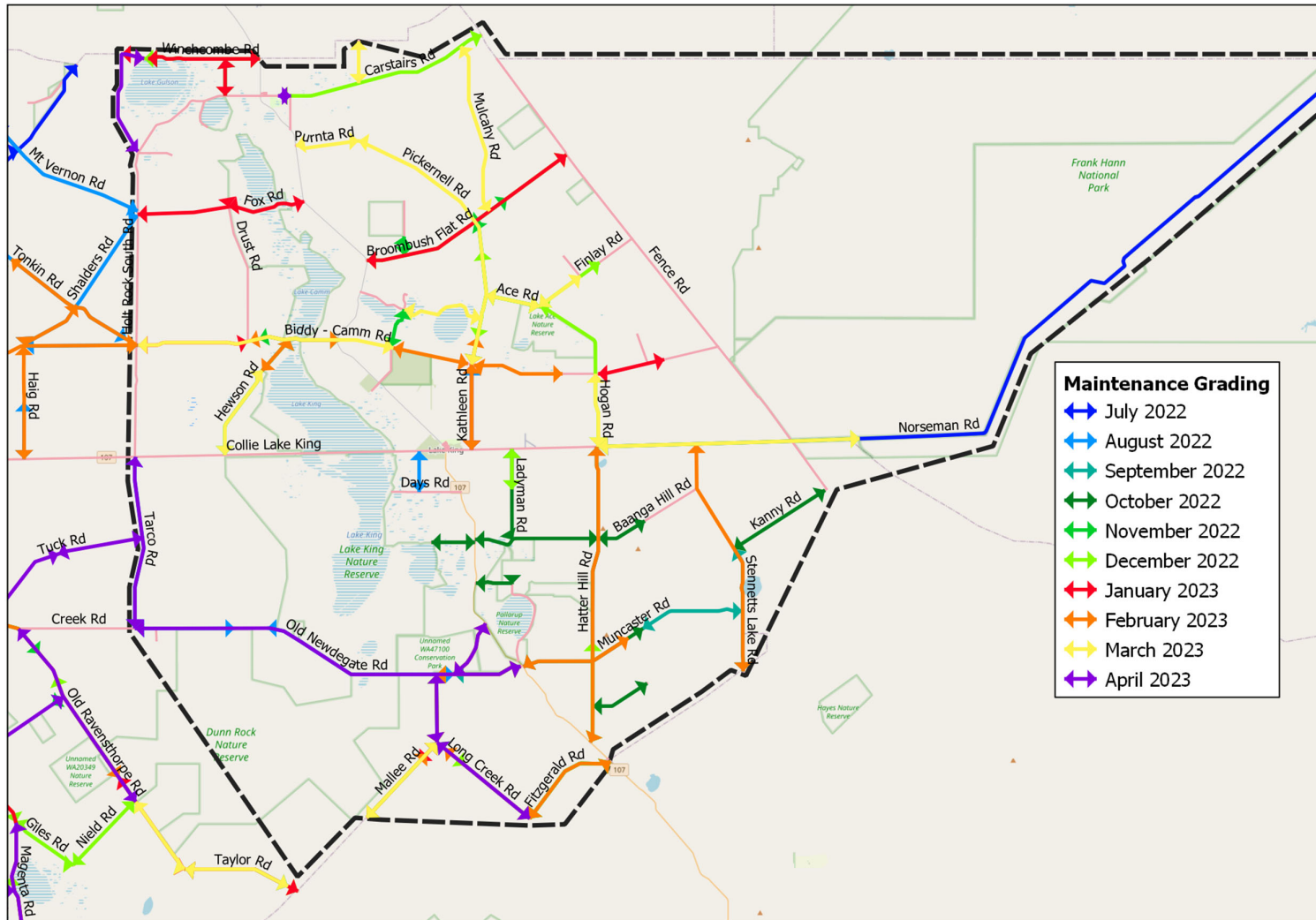

Monthly maintenance grading – Lake King-Varley area

Plant Maintenance

Plant Repairs

Plant	Plant Description	Action
PLVU45	2020 Ford Ranger Single Cab	45,000 km service.
PLVU46	2020 Ford Ranger Single Cab	45,000 km service.
PTRA18	2007 Earnshaw Float	Replacement axle.

Building Construction & Maintenance

Construction

- Installation of fence at the Lake Grace Visitor's Centre Park.

Maintenance

Lake Grace

- Assessment of 8 Wattle Drive.

Newdegate

- Nil.

Lake King

- Repair of doors at Emergency Shed.

Varley

- Nil.

Parks & Gardens Maintenance

Lake Grace

- General maintenance, gardening/mowing & tidying of gardens and parks.
- Spraying of verges.

Newdegate

- General maintenance, gardening/mowing of the recreation grounds, parks and skate park.
- Spraying of verges.

Lake King

- Carried out general gardening, mowing and spraying to all parks and gardens.
- Spraying of verges.

Varley

- Carried out gardening maintenance and general maintenance, including spraying, mowing, raking of the town site, sports complex and cemetery for weeds.
- Spraying of verges.

Pingaring

- Nil.

Customer Service Requests

For the period of 1 July 2022 to 30 April 2023:

Category	Complete	Incomplete	Total	% Complete
Works	15	10	25	60.0%
Building	12	9	21	57.1%
Parks & Gardens	23	7	30	76.7%
<i>Total</i>	<u>50</u>	<u>26</u>	<u>76</u>	<u>65.8%</u>

Lake King Library Report for April 2023

We collected our new display boxes from DVA Perth which were kindly purchased by LK Primary School and the Shire. It is nice to be able to spread our growing junior fiction collection out so that it can be accessed easily by small hands.



The “Lake King 100 Years” planning committee met again this month in the library. Although five years away keen community members have started discussion and plan to meet the last Friday of the month going forward.

The books have arrived for the Scholastic Book Fair due to run for two weeks in May. Hopefully lots of sales and therefore commission books to add to our collection.

The State Library’s Borrow box had a total of 30 audios and 7 eBooks borrowed by Lake King library members in April. The Libby (Overdrive) platform had 5 audio books, 3 eBooks and 7 magazines downloaded by patrons in April.

Statistics Interlibrary Loans

April	VDX Lake King Requests received from other libraries	1
	VDX Responded to other Library requests to borrow	2

Central Country Zone

Minutes

Friday, 14 April 2023
Commenced at 9.35am

Venue:

McDougall Hall
Lions Dryandra Woodland Village
Tomingley Rd, Dryandra 6311

Hosted by Shire of Cuballing

TABLE OF CONTENTS

1.	Opening and Welcome	4
2.	Attendance	4
3.	Declarations of Interest	6
4.	Announcements	6
5.	Guest Speakers / Deputations	7
5.1	Kellie Todman, Manager Government and Industry Relations, CBH.....	7
5.2	Brett Dew, Field Operations Team Leader, Narrogin Depot, Western Power	7
6.	Members of Parliament.....	7
7.	Agency Reports	8
7.1	Department of Local Government, Sport, and Cultural Industries (DLGSC).....	8
7.2	Wheatbelt Development Commission (WDC)	8
7.3	Regional Development Australia Wheatbelt (RDAW).....	8
7.4	Main Roads Western Australia	8
8.	Minutes.....	9
8.1	Confirmation of Minutes from the Central Country Zone meeting, 10 February 2023.	9
8.2	Business Arising, Central Country Zone Meeting, 10 February 2023.....	9
8.3	Minutes of the Central Country Executive Committee Meeting, 5 April 2023	9
8.3.1	(Item 5.6.1) Wheatbelt Interagency Health & Wellbeing Plan.....	9
8.3.2	(Item 5.6.3) Central Country Zone Emergency Management MOU.....	9
8.3.3	(Item 5.6.4) June Zone meeting – change of date request.....	10
8.3.4	(Item 7.1) Bushfire Permits	10
8.4	Minutes of the Central Country Executive Committee Meeting, 5 April 2023	11
9.	Zone Business.....	11
9.1	Financial Burden to Local Governments of Optional Preferential Voting.....	11
10.	Zone Reports.....	13
10.1	Zone President Report	13
10.2	Local Government Agricultural Freight Group (LGAFG)	13
10.3	Great Southern District Emergency Management Committee (DEMC).....	13
10.4	Regional Health Advocacy Group.....	13
10.5	WALGA RoadWise.....	13
11.	Western Australian Local Government Association (WALGA) Business	14
11.1	2023 Local Government Honours Program	14
11.2	State Councillor Report	14
11.3	WALGA Status Report.....	19
11.4	Review of WALGA State Council Agenda – 3 May 2023	24
11.5	WALGA President’s Report.....	29
12.	Emerging Issues	30



- 13. Date, Time, and Place of Next Meeting.....30
- 14. Closure30

1. Opening and Welcome

Chair President Leigh Ballard was an apology for the meeting. Deputy Chair Des Hickey Chaired the meeting.

The Chair declared the meeting open at 9:35am.

1.1 Housekeeping – Zone Chair

1. Welcome:

The Zone Chair welcomed Zone members and provided OSH/bathroom/exit information to those in attendance.

2. Share your name and Local Government:

Delegates were reminded to ensure that they call their name and Local Government when taking the floor to allow for accurate Minutes to be recorded.

1.2 Host Council Presentation

Cr Rob Harris, Deputy President from the Shire of Cuballing, extended a welcome to delegates and guests.

2. Attendance

Shire of Beverley

President Cr David White
Deputy President Cr Chris Lawlor
Mr Steve Gollan Chief Executive Officer, non-voting

Shire of Brookton

President Cr Katrina Crute
Deputy President Cr Neil Walker
Cr Tamara Lilly, non-voting
Mr Gary Sherry Chief Executive Officer, non-voting

Shire of Corrigin

President Cr Des Hickey (Acting Chair)
Cr Sharon Jacobs

Shire of Cuballing

Deputy President Cr Rob Harris
Mr Stan Scott Chief Executive Officer, non-voting

Shire of Dumbleyung

President Cr Julie Ramm
Mr Gavin Treasure Chief Executive Officer, non-voting

Shire of Kulin

Cr Robbie Bowey

Shire of Lake Grace

Deputy President Cr Ross Chappell
Mr Alan George Chief Executive Officer, non-voting

Shire of Narrogin

Cr Graham Broad

Shire of Pingelly	Deputy President Cr Jackie McBurney Mr Andrew Dover Chief Executive Officer, non-voting
Shire of Quairading	Cr Jo Haythornthwaite Cr Trevor Stacey
Shire of Wagin	President Cr Phillip Blight Mr Ian McCabe Chief Executive Officer, non-voting
Shire of Wandering	President Cr Ian Turton
Shire of West Arthur	Cr Karen Harrington Mr Rajinder Sunner Acting Chief Executive Officer, non-voting
Shire of Wickepin	Deputy President Cr Wes Astbury
Shire of Williams	President Cr Jarrad Logie
<u>Guests</u>	
CBH	Kellie Todman, Manager Government and Industry Relations
Western Power	Kaila Eva, Senior Analyst, Network Planning Kristina Primus, Principal, Network Planning
Main Roads WA	Brett Dew, Field Operations Team Leader, Narrogin Depot Mohammad Siddiqui, Director Wheatbelt Region
Water Corporation	Brad Pearce, Operations Manager Narrogin Michael Roberts, Regional Manager Goldfields & Agricultural Region
Regional Development Australia WA	Mandy Walker, Director Regional Development
<u>Members of Parliament</u>	
	Hon Mia Davies MLA, Member for Central Wheatbelt Hon Steve Martin MLC, Liberal Member for the Agricultural Region Hon Shelley Payne MLC, Member for Agricultural Region
<u>WALGA</u>	
	Tony Brown, Executive Director Member Services Kathy Robertson, Executive Officer Governance Rodney Thornton, Regional Road Safety Advisor
<u>Apologies</u>	
Shire of Corrigin	Ms Natalie Manton Chief Executive Officer, non-voting Deputy President Cr Mike Weguelin
Shire of Cuballing	President Cr Eliza Dowling
Shire of Dumbleyung	Deputy President Cr Amy Knight
Shire of Kulin	Mr Alan Leeson Chief Executive Officer, non-voting Deputy President Cr Brad Smoker Cr Barry West President Cr Grant Robins
Shire of Lake Grace	President Cr Len Armstrong
Shire of Narrogin	President Leigh Ballard

Shire of Pingelly Shire of Quairading	Mr Dale Stewart Chief Executive Officer, non-voting President Cr Bill Mulrone President Cr Peter Smith Cr Jonathan Hippisley
Shire of West Arthur Shire of Wagin Shire of Wandering	Ms Nicole Gibbs Chief Executive Officer, non-voting Mr Vin Fordham Lamont, Chief Executive Officer Deputy President Cr Gregory Ball Deputy President Cr Paul Treasure
Shire of West Arthur Shire of Wickepin	Mr Alan Hart Chief Executive Officer, non-voting President Cr Neil Morrell President Cr Julie Russell
Shire of Williams	Mr Nathan Cain Chief Executive Officer, non-voting Cr Moya Carne Mr Geoff McKeown Chief Executive Officer, non-voting
Members of Parliament	Hon Sandra Carr MLC, Member for Agricultural Region Hon Peter Rundle MLA, Member for Roe Hon Colin de Grussa MLC, Member for Agricultural Region Rick Wilson MP, Federal Member for O'Connor Hon Martin Aldridge MLC, Member for Agricultural Region Hon Darren West MLC, Member for Agricultural Region
Wheatbelt Development Commission	Susan Hall, Acting Chief Executive Officer Pip Gooding, Regional Development Officer – Wheatbelt South
Department of Local Government, Sport, & Cultural Industries	Samantha Cornthwaite, Regional Manager Wheatbelt

Attachments to Minutes

The following are provided as attachments to the Minutes:

1. Item 5.1 CBH presentation
2. Item 5.2 Western Power presentation

3. Declarations of Interest

Nil

4. Announcements

Nil

5. Guest Speakers / Deputations

5.1 Kellie Todman, Manager Government and Industry Relations, CBH

Kellie Todman, along with Kaila Eva and Kristina Primus, presented on the Agricultural Supply Chain Initiative as well as forecasting and capital investment over the next ten years. This presentation is now attached (**Attachment 1**).

5.2 Brett Dew, Field Operations Team Leader, Narrogin Depot, Western Power

Brett Dew from Western Power presented on Pole Top Fires with specific reference to the types of insulators used on power poles and the effect this may have on pole top fires. This presentation is now attached (**Attachment 2**).

6. Members of Parliament

Members of Federal and State Government, representing the Zone Member Local Government Districts, were invited to provide a brief update on matters relevant to Zone Members.

State Members:

- Hon Mia Davies MLA, Member for Central Wheatbelt
 - Provided an update on her portfolios: Aboriginal affairs, electoral affairs, and mines/petroleum
 - The guidelines for the new *Aboriginal Cultural Heritage Act (2021)* were released last week
 - The new Act and Regulations will take effect from 1 July 2023
 - Aboriginal Affairs Minister Dr Tony Buti has made assurances about the consultation process requirements under the Act
 - However, there is still a level of concern about (mis)understanding in the broader community
 - The WAEC has just released calls for submissions to boundary changes for the next election in 2025
 - The Nationals are asking for Local Government and community groups to consider putting in a submission
 - There will likely be a significant redistribution with this election, in both the Upper and Lower House, including a risk of reduction of regional seats in the Lower House
 - Submissions close 1 May
 - State budget upcoming in May
 - Anticipating a significant surplus
 - Live export
 - The Nationals are maintaining pressure on the State Government on this issue
 - Ports
 - There is an internal review of ports underway by the State Government
- Hon Steve Martin MLC, Liberal Member for the Agricultural Region
 - Live export
 - The Liberals will continue to advocate on this issue
 - The consultation process is about transitioning out of live trade, and given it is such a big industry, a full shut down would be a lengthy process

- The Premier should be throwing his weight around on this issue
 - Housing
 - Housing is tough everywhere
 - Shire of Trayning has been asked by the State Government to build houses
- Hon Shelley Payne MLC, Member for Agricultural Region
 - Local Government Amendment Bill 2023
 - The Bill passed the Lower House last month
 - Criminal Law (Mental Impairment) Bill 2022
 - Passed through Parliament recently
 - Statutory review of the Biosecurity and Agriculture Management Act
 - The review is well underway, with the main consultation completed
 - The review is now moving into Stage 2

7. Agency Reports

7.1 Department of Local Government, Sport, and Cultural Industries (DLGSC)

The Department of Local Government, Sport, and Cultural Industries representative was an apology for this meeting however have provided a report which was attached to the Agenda.

The Department ask that if you have any questions, WALGA will note and send to DLGSC, the response will come back to you through WALGA. For individual queries from members, a list of DLGSC contacts have been provided within the report.

Noted

7.2 Wheatbelt Development Commission (WDC)

Pip Gooding, Regional Development Officer – Wheatbelt Development Commission was an apology for this meeting.

Noted

7.3 Regional Development Australia Wheatbelt (RDAW)

Mandy Walker, Director Regional Development, provided a report to the Zone. The RDAW report for February 2023 was attached to the Agenda.

Noted

7.4 Main Roads Western Australia

Mohammad Siddiqui, Director Wheatbelt Region and Brad Pearce, Operations Manager Narrogin, provided a report to the Zone that was distributed prior to the meeting.

Noted

8. Minutes

8.1 Confirmation of Minutes from the Central Country Zone meeting held on Friday, 10 February 2023

The Minutes of the Central Country Zone meeting held on Friday, 10 February 2023 have previously been circulated to Member Councils.

WALGA RECOMMENDATION

Moved: President Cr Phil Blight

Seconded: Cr Ross Chappel

That the minutes of the Central Country Zone meeting held on Friday, 10 February 2023 be confirmed as a true and accurate record of the proceedings.

CARRIED

8.2 Business Arising from the Minutes from the Central Country Zone Meeting held on Friday, 10 February 2023

Nil

8.3 Minutes of the Central Country Executive Committee Meeting held on Wednesday, 5 April 2023

The recommendations from the Executive Committee Meeting that require Zone consideration have been extracted for the Zones consideration.

8.3.1 (Item 5.6.1) Wheatbelt Interagency Health & Wellbeing Plan

Background

WA Country Health Service-Wheatbelt contacted the Zone Executive Officer in March of 2023.

In summary, a working group is being formalised to develop the *Wheatbelt Interagency Health & Wellbeing Plan: Towards 2035 Working Group WAPHA membership*. WA Country Health Service are taking expressions of interest for one Local Government representative from each Zone in the Wheatbelt to sit on the working group.

The Chair seeks feedback from the Members; is there an interest from a Zone perspective and would anyone like to nominate themselves to be on the working group.

Cr Jackie McBurney nominated for a position on the working group and was elected unopposed.

RESOLVED

8.3.2 (Item 5.6.3) Central Country Zone Emergency Management MOU

Background

At the February 2023 Zone meeting, the Zone recommended a new draft MoU be circulated to Members in order to determine if the Local Government is interested in extending the MoU for a further two years from three to five years. The draft MOU (which was attached to the Agenda) was circulated with the following responses:

The Shires of Beverley, Brookton, Corrigin, Cuballing, Dumbleyung, Lake Grace, Narrogin, Pingelly, Quairading, Wagin, Wandering, Wickepin and West Arthur are in support of extending the MoU. We await a response from the Shire's of Kulin and Williams.

ZONE RECOMMENDATION

Moved: President Cr Katrina Crute
 Seconded: President Cr Phil Blight

That the Central Country Zone endorse the Emergency Management MOU for a 5 year period.

CARRIED

8.3.3 (Item 5.6.4) June Zone meeting – change of date request

Background

The Central Country Zone meeting is scheduled for Friday 16 June 2023. This is the same date as the Australian Council of Local Government forum to be held in Canberra following the 2023 ALGA National General Assembly.

The Executive Committee resolved to change the June meeting date from Friday 16 June 2023 to Friday 23 June 2023.

Noted

8.3.4 (Item 7.1) Bushfire Permits

Background

The Executive Committee discussed the new bushfire permits, where the new system has added a restriction on burning with a high fire hazard, whereas previously it was only banned with extreme or catastrophic rating.

The Committee Chair advised that the way around this is for the Local Government to appoint fire weather officers and these officers can provide approval for burning in a high, extreme or catastrophic situation.

Please note the following sections of the *Bush Fires Act 1954 (WA)*:

Section 38(8)

“...fire weather officer”

Section 38(9)

“Where more than one fire weather officer is appointed by a local government the local government shall define a part of its district in which each fire weather officer shall have the exclusive right to exercise the power conferred by subsection (17).”

Section 38(13)

“The local government shall give notice of an appointment made under subsection (8) or (10) to the FES Commissioner and cause notice of the appointment to be published at least once in a newspaper circulating in its district and the FES Commissioner shall cause notice of the appointment to be published once in the Government Gazette.”

Section 38(14)

"...appoint a committee"

Section 38(17)

"A fire weather officer of an approved local government, or a deputy of that fire weather officer while acting in the place of that officer, may authorise a person who has received a permit under section 18(6)(a), to burn the bush in the district of the local government notwithstanding that for any day, or any period of a day, specified in the notice the fire danger forecast issued by the Bureau of Meteorology in Perth, in respect to the locality where the bush proposed to be burnt is situated, is "catastrophic", "extreme", "severe" or "very high", and upon the authority being given the person, if he has otherwise complied with the conditions prescribed for the purposes of section 18, may burn the bush."

Section 38(18)

"...prohibited burning times"

Noted

<p>8.4 Minutes of the Central Country Executive Committee Meeting held on Wednesday, 5 April 2023</p>
--

The Minutes of the Central Country Zone Executive Committee meeting held on Wednesday, 5 April 2023 were attached to the Agenda.

The remainder of the items are for the Zones consideration.

WALGA RECOMMENDATION

Moved: President Cr Katrina Crute

Seconded: President Cr Phil Blight

That the Minutes of the Central Country Zone Executive Committee Meeting held on Wednesday, 5 April 2023 be noted, and the items not considered above be endorsed.

CARRIED

9. Zone Business

<p>9.1 Financial Burden to Local Governments of Optional Preferential Voting</p>

By Andrew Dover, Chief Executive Officer, Shire of Pingelly

Attachment (provided with the Agenda)

Memorandum to Chief Executive Officers - Arrangements for the Upcoming October 2023 Ordinary Elections

Summary

For the Zone to consider the financial implications of the recently introduced Optional Preferential Voting and form an advocacy position that the additional cost of this imposed change should not be borne by ratepayers.

Background

The most recent Local Government Act reforms passed by parliament in March 2023 related primarily to electoral reform. These reforms include:

- optional preferential voting;
- directly-elected Mayors and Presidents for Bands 1 and 2;
- the abolition of wards for Bands 3 and 4;
- reducing the number of councillors in most Local Governments; and
- backfilling of vacancies rather than extraordinary elections.

The Memorandum to Chief Executive Officers - Arrangements for the Upcoming October 2023 Ordinary Elections (the Memorandum) asserts that the last two dot points above will 'save costs for ratepayers and administrative burden for local governments in the longer term.' However, not all Local Governments are reducing the number of Councillors and extraordinary elections are rare so the cost savings from these reforms are limited.

A greater quantity of work is required to hold a preferential voting election, which will result in significant cost increases regardless of if the elections are held internally or by the Western Australian Electoral Commission (WAEC). WAEC is currently charging up to 25% more to hold an election when compared the rate two years ago while internally hold elections have to contend with additional hours for staff at penalty rates and the purchase of the licence for the CountWA software to facilitate the counting of votes from WAEC.

Policy Implications

This report is intended to commence the process for WALGA to form a policy position on this matter.

Statutory Implications

The Local Government Act 1995 requires each Local Government is required to hold elections every two years (unless the seats are filled uncontested) and to bear the cost of these elections.

Financial Implications

These electoral reforms impose an additional financial burden on Local Governments. This report is an attempt to offset this impost.

Comment

The State Government have imposed these reforms on Local Governments with the stated aim of aligning the Local Government elections with those of the State and Federal Governments against majority feedback from the Local Government sector. The cost of this decision should therefore be borne by the State Government.

There would naturally be an increase in costs for WAEC to provide election services. However, this would not exceed 10%, considering that the all sector Wage Price Index increased by only 2.4% in 2021 and 3.3% in 2022. This percentage is anticipated to increase in 2023. Any increase over and above 10% must therefore arise from the introduction of preferential voting. Consequently, it would be reasonable to request the State Government cap any increase to a maximum of 10%.

There also is the increase in costs for Local Governments to staff the elections if operated internally due to the increased length of time anticipated for counting. On top of this is the recommended purchase of the licence for the CountWA software. This software currently is used for State elections and therefore the development costs have already been met. Other costs would be minimal.

Consequently, it would be reasonable to request the State Government to provide this software to Local Governments free of charge.

RECOMMENDATION

Moved: President Cr Phil Blight

Seconded: President Cr Ian Turton

That WALGA forms a policy position and advocates that:

- 1. Any Western Australian Electoral Commission fee increases for the 2023 Local Government elections are capped at 10% when compared with the 2021 rates; and**
- 2. That the CountWA software from Western Australian Electoral Commission is provided to Local Governments free of charge for the 2023 and subsequent Local Government elections.**

CARRIED

10. Zone Reports

10.1 Zone President Report

Zone Chair President Leigh Ballard was an apology for this meeting.

Noted

10.2 Local Government Agricultural Freight Group (LGAFG)

Cr Katrina Crute advised that the Local Government Agricultural Freight Group has not met.

Noted

10.3 Great Southern District Emergency Management Committee (DEMC)

President Leigh Ballard was an apology for this meeting.

Noted

10.4 Regional Health Advocacy Group

Ms Natalie Manton was an apology for this meeting.

Noted

10.5 WALGA RoadWise

Rodney Thornton, Regional Road Safety Advisor did not provide a report.

Noted

11. Western Australian Local Government Association (WALGA) Business

11.1 2023 Local Government Honours Program

The annual Local Government Honours Program affords significant public recognition and celebration of the outstanding achievements and lasting contributions made by Elected Members and Local Government officers to their respective Councils, the WA Local Government sector, and the wider community.

Nominations for the 2023 Honours Program are open now.

There are six awards in the 2023 Program:

1. Local Government Medal
2. Life Membership
3. Eminent Service Award
4. Merit Award
5. Local Government Distinguished Officer Award
6. Young Achievers Award

Nominations will close at **5:00pm on Friday, 9 June** and the awards will be presented as part of the WALGA Annual General Meeting held on Monday, 18 September.

For more information or to submit a nomination, visit the WALGA website or contact Kathy Robertson, Executive Officer Governance, on 9213 2036 or via email at honours@walga.asn.au.

Noted

11.2 State Councillor Report

Cr Phillip Blight

There were a number of items on the Agenda which were of significance to the Zones and the membership at large, in particular items relating to the 'Proposed Advocacy Position on Constitutional Recognition of Aboriginal and Torres Strait Islander People' and WALGA's 'Best Practice Governance Review Final Report'.

The following information is a little long winded, but I thought you needed to know the detail.

1. 'Proposed Advocacy Position on Constitutional Recognition of Aboriginal and Torres Strait Islander People'. (Item 7.1)

This item has been the subject of much discussion and division amongst State Councillors, with Zones generally providing a strong response on the direction that should be taken regards WALGA's advocacy position on the Referendum. You may recall State Council passed the following composite recommendation at its meeting on 7th December 2022.

1. *Supports a robust and respectful national debate on constitutional recognition for Aboriginal and Torres Strait Islanders and requests the Commonwealth Government provide furtherdetails on the proposed Voice to Parliament.*
2. *Requests that the Commonwealth Government ensure that Local Governments and local communities across WA are meaningfully engaged with on this issue.*

3. *Requests WALGA prepare an advocacy position in support of constitutional recognition to be circulated to WALGA Zones for their next meeting for consideration and feedback.*

As you are aware, WALGA produced the attached 'Constitutional Recognition Information Paper 18th January 2023' for consideration by Zones and the membership in general. State Council did resolve that the Administration provide an advocacy position on that element of the referendum relating to 'Constitutional Recognition' and not the referendum question relating to 'The Voice'. As can be seen from the Information Paper the advocacy position morphed into support for both. In any event, Zones were asked to consider the paper and provide a response. This matter was then to be put to State Council for decision at the meeting on 1st March 2023.

Of the 17 Zones, 13 Zones provided a response to WALGA following the February 2023 round of Zone meetings. Murchison Country Zone did not formerly respond as it does not hold its meeting until April 2023. Of the 13 Zones which did respond only 1 (South East Metropolitan Zone) fully supported WALGA's advocacy position while 9 (if you include the Murchison Country Zone) recommended that WALGA not advocate a position on the referendum and that it not be involved in this space. Responses from a further 2 Zones (Peel and Pilbara) recommended that the matter lay on the table for further deliberation while the Central Metropolitan Zone did not support WALGA's advocacy position but did provide an alternate motion based on the content noted at point 1 above (highlighted in red). Finally, the North Metropolitan Zone supported point 1. above along with a recommendation for '*the funding of representative bodies and inclusion of changes led by such bodies in legislation*' (?).

Based on responses from the Zones the Administration put forward the following composite recommendation for decision at the State Council Meeting on 1st March 2023:

That WALGA:

1. *Supports a robust and respectful national debate on constitutional recognition for Aboriginal and Torres Strait Islanders and requests the Commonwealth Government provide further details on the proposed Voice to Parliament.*
2. *Requests that the Commonwealth Government ensure that Local Government and local communities across WA are meaningfully engaged with on this issue.*
3. *Does not take a position on Constitutional Recognition of Aboriginal and Torres Strait Islander People through the enhancing of a Voice to Parliament at this time.*

This motion was not debated as an alternate motion was put up by the Central Metropolitan Zone. It followed that Zone's recommendation in the Agenda which reads:

'That the Central Metropolitan Zone supports a robust and respectful national debate on constitutional recognition for Aboriginal and Torres Strait Islanders and requests the Commonwealth Government provide further details on the proposed Voice to Parliament'.

The Alternate Recommendation finally proposed by Cr. Helen Sadler from the Central Metropolitan Zone was as follows:

1. *Supports respectful conversations about constitutional recognition of Aboriginal and Torres Strait Islanders and the Voice to Parliament.*
2. *Requests that the Commonwealth Government ensure that Local Governments and communities are kept informed on the proposal.*

The alternate motion was carried.

Some around the table could not see the purpose of this alternate motion as it pretty much followed points 1 & 2 of the original recommendations already passed at the State Council meeting on 7th December 2022 (see above highlighted in red). The Administration determined that the advocacy position was unlikely to be carried and therefore, the recommendation in point 3 above was not to take a position on Constitutional Recognition. The alternate recommendation was accepted.

Although divided, the mood at State Council was pretty definite in that the majority of Zones recommended WALGA was not to advocate for Constitutional Recognition and that accepting the alternate resolution was simply a reinforcement of the resolution of 7th December 2022 without WALGA adopting a position on either of the referendum questions.

2. WALGA's 'Best Practice Governance Review Final Report'. (Item 7.6)

As we are all aware, 5 options were put to the membership around a potential change to WALGA's governance model. All member councils were given an opportunity to comment and, of the 139 Local Government members, 99 responded. Of these, 90 provided a preference and 9 responded but did not recommend a preference (?). A number of other submissions were received, and a survey was conducted by IPSOS on behalf of WALGA to which 13 of 24 State Councillors undertook the survey and approximately 8% of 1,338 other invitations sent out responded. The Steering Committee meet on 8 or 9 occasions to review the makeup of the various options and produce a recommendation for State Council to consider at the meeting on 1st March 2023 based on the feedback from the membership and the survey responses from the IPSOS report.

It was recommended that Option 1 be put to State Council to endorse to then be voted on at the 2023 AGM.

For your information, for there to be a change to the Constitution 75% of the State Council must pass the recommendation following which at least 75% of the membership must also pass the recommendation at the 2023 AGM. Please see the Stage 3 Final Report for further detail. A report by IPSOS confirmed that Option 5 was the preferred model on a 'first past the post' system of voting however, Option 1 was preferred based on a distribution of preferences as there appeared to be a mood for change amongst some members. Change was a focus with all but one of the metropolitan Zones.

An issue was raised by a number of State Councillors that the preference system was essentially flawed. Of the 90 Council members that made a recommendation not all 5 options were selected in order of preference. Therefore, it was difficult to apply preferences that reflected the whole of the sector. The first round of preferences was evenly divided between Option 1 and Option 5. In light of the lack of completion of all 5 preferences by the membership a definitive outcome could not be clearly identified. It was suggested from the responses that many members were supportive of a change, but whether that support translated into support for Option 1 over Option 5...that would be up to the membership to decide at the 2023 AGM.

Another issue was raised in that there were a further 40 Member Councils which did not respond to the survey and 9 which did respond but did not provide a recommendation. This is a significant percentage of the total 139 membership whose opinion has not been recorded. These councils need to be engaged with so as to get a whole of membership preference before a final recommendation can be put to the State Council and then the members at the 2023 AGM. A number of State Councillors commented that the figures provided by IPSOS were confusing, incomplete and did not provide a true reflection of the membership's position on a preferred model.

The Agenda recommendation to State Council was quite narrow in that... ***'The proposed changes to WALGA's governance structure as per the revised Model 1 as detailed in the Stage 3 Final Report be endorsed'***. The recommendation was devoid of any reference to Option 5 as the current model. Some suggested that a lack of reference to Option 5 in the recommendation to change the governance model could lead the membership to thinking that only Option 1 was a consideration. Others considered that Option 5 need not be referred to in any recommendation as it is the default model should Option 1 fail to be endorsed by the membership. Some clarity was needed so that the members were clearly aware that Option 5 is still the current Model while Option 1 is proposed as an alternative.

Therefore, an amendment to the recommendation was proposed to read ***'any recommendation to the 2023 AGM include Option 5 as the current model and Option 1 as an alternative to the current model'***. This recommendation was carried.

A further recommendation was that ***'Members be engaged on the detail of the model and a Final Report be presented to the May 2023 State Council meeting for consideration'***. This motion was carried. Therefore, WALGA will seek further feedback from all member councils as to what changes the membership might consider in relation to Option 1.

To sum up, there was little separation between Option 1 and Option 5 (current model) as the most favoured model. The survey results were inconclusive of a clear favourite. The membership is asked to **review Option 1 to develop the model further**. Of importance is representation at the regional level and that any change must consider this impact. Members were clear that representation has to be an essential part of the governance model going forward. I have been in favour of change for some time however we must be clear that any change will improve Walga. I am yet to be convinced that model 1 will attract quality candidates to nominate for State Council. In my 16 years at CC Zone I have only seen two elections. It is not the desired position now that it should be. We must be confident that any change will encourage enthusiasm to represent, bearing in mind that in model 1, the peak body will have only four representatives for all of regional WA.

The current communique is not asking for a final vote, that will be at the 2023 WALGA AGM however any tweaks to model 1 will come before State Council at its May 2023 meeting.

Contrary to some publication, there has been no decision made to support either model ,they are both on the table for further discussion.

This matter was divisive and hotly debated. The amended recommendation was passed. The details will be provided in the Minutes of the Meeting in due course.

If you prefer any further information, I would be happy to discuss with any of the members.

3. Child Safeguarding Advocacy Position (Item 7.3)

State Council supported the WALGA Recommendation which identified the recommendations from the Royal Commission into institutional Responses to Child Sexual Abuse 2017. Recommendation 6.12 of the report was supported which recommended Local Government implement and embed child safeguarding across its functions. The recommendation went further to request State Government provide the funding, resources and capacity building to Local Governments to achieve child safeguarding.

4. Submission on Draft Guideline Minimising Noise Impact from Outdoor Community Basketball Facilities. (Item 7.4)

Minister Reece Whitby, Minister for Environment, has removed the need to comment on the Draft Guidelines. As the Draft Guidelines have been rescinded, WALGA's submission is no longer valid.

Noise levels on outdoor basketball courts has been a continuing problem for residents in built up areas and where there is medium to heavy density residential living.

5. Other Matters.

- The BAM Act Review is ongoing with Stage 3 expected in Mid April. WALGA continues to engage with stakeholders on this issue, including an upcoming meeting with Hon. Jackie Jarvis, Minister for Agriculture and Food; Forestry; Small Business; Citizenship and Multicultural Interests.
- WALGA is collaborating with Government on a transition to electric vehicles. In this regard WALGA has commissioned a consultant to develop a template 'Fleet Transition Plan'.
- 20 Local Governments have agreed to be part of the ARENA (Australian Renewable Energy Agency) funding bid with positive funding opportunities from the State Government if the WALGA ARENA bid is successful. The bid will go into the full project proposal phase in April 2023 for consideration in May 2023.

That's about it for the moment. It has been a busy time on all levels of Local Government, and I will keep you posted as further detail is discussed and in need of a Zone or membership response.

If anyone wants further clarification, please don't hesitate to contact me and please feel free to share this with your fellow councillors.

RECOMMENDATION

Moved: Cr Jackie McBurney
Seconded: Cr Neil Walker

That the State Councillor Report be received.

CARRIED

11.3 WALGA Status Report

By Tony Brown, Executive Officer

BACKGROUND

Presenting the Status Report for April 2023 which contains WALGA's responses to the resolutions of previous Zone Meetings.

CENTRAL COUNTRY ZONE STATUS REPORT April 2023

Zone	Agenda Item	Zone Resolution	WALGA Response	Update	WALGA Contact
Central C	2022, 18 February Zone Agenda Item 11.1	That the Central Country Zone recommend that the Local Government Agricultural Freight Group be disbanded and request WALGA to consider establishing a policy forum to encompass all Freight issues.	<p>The Infrastructure Policy Team noted that a decision to disband the Agricultural Freight Group is a matter for the participating Zones.</p> <p>The Infrastructure Policy Team considered potential terms of reference for an Agricultural Freight Policy Forum at their December meeting and ultimately determined to ask WALGA staff to identify deficiencies in the current State Government freight strategy in the Agricultural region to inform their consideration. The strategy is covered in five documents:</p> <p>Revitalising Agricultural Region Freight Strategy (2018)</p> <ul style="list-style-type: none"> • Draft South West Supply Chain Strategy (2020) • Regional Freight Plan (2013) • Agricultural Supply Chain Improvement Program (ASCI) – Phase 1 (2021) • Infrastructure Australia – Western Australia Agricultural Supply Chain Improvements Proposal 	Ongoing	<p>Ian Duncan Executive Manager Infrastructure iduncan@walga.asn.au 9213 2031</p>



			<p>The December Policy Team meeting did not have time to further discuss deficiencies in the strategy that may support the case for a Policy Forum.</p> <p>In the immediate term, funding that has been provided by the Federal Government, specifically in the Secondary Freight network programs (Wheatbelt, Mid West and Great Southern) and rail siding investments exceed the capacity of the construction industry to deliver.</p> <p>However, there is likely to be the need for strategic planning for medium term investments.</p>		
Central C	2019 Nov 29 Zone Agenda Item 10.8 Western Australia's Share of Fuel Excise	That WALGA prepares and endorses a strategy to obtain transparency of the distribution of the fuel excise with the intent to maximise the return to Western Australia for road maintenance.	<p>The resolution has been referred to the Infrastructure Policy Team and based on direction provided further research to support an advocacy position is being carried out.</p> <p>The Association met with the RAC and received access to a 2020 revision of a report commissioned by the RAC quantifying motorist taxation and Federal Government investment in WA transport infrastructure.</p>	Ongoing	<p>Ian Duncan Executive Manager Infrastructure iduncan@walga.asn.au 9213 2031</p>
Central C	1 March 2023 State Council Agenda Item 7.1 Proposed Advocacy Position on Constitutional Recognition of Aboriginal and Torres Strait Islander People	<p>That:</p> <ol style="list-style-type: none"> the Central Country Zone acknowledge the importance of the recognition of all Australians in the Australian Constitution; and the Central Country Zone does not believe WALGA should actively participate in the national referendum on the Voice to Parliament. 	<p>State Council Resolution</p> <p>That WALGA:</p> <ol style="list-style-type: none"> Supports respectful conversations about constitutional recognition of Aboriginal and Torres Strait Islanders and the Voice to Parliament. Requests that the Commonwealth Government ensure that Local Governments and communities are kept informed on the proposal. <p>COMPLETE</p>	April 2023	<p>Nicole Matthews Executive Manager Policy nmatthews@walga.asn.au 9213 2039</p>
Central C	1 March 2023 State Council Agenda Item 7.3 Child Safeguarding Advocacy Position	That the Central Country Zone acknowledges the work carried out by the Department of Local Government, Sport and Cultural Industries through the Child Safety feedback and consultation process, and reaffirms that Local Governments should not be listed as a Reporting Agency.	<p>That the Child Safeguarding Advocacy Position as follows be endorsed:</p> <p>Child Safeguarding</p> <ol style="list-style-type: none"> Local Government supports: <ol style="list-style-type: none"> the recommendations from the Royal Commission into Institutional Responses to Child Sexual Abuse 2017, in particular Recommendation 6.12 which can be achieved by Local Government implementing and embedding child safeguarding across its functions with 	April 2023	<p>Nicole Matthews Executive Manager Policy nmatthews@walga.asn.au 9213 2039</p>



			<p>support from Governments at the national, state and territory levels; and</p> <p>b. the ten National Principles for Child Safe Organisations (Australian Humans Rights Commission).</p> <p>2. The State Government through an Independent Oversight Body should provide financial, resourcing and capacity building support to Local Governments to implement and embed child safeguarding across its functions, through the provision of:</p> <p>a. supporting materials such as template policies, procedures and guidelines;</p> <p>b. consistent key messaging and resources to promote and share in venues and facilities and online;</p> <p>c. examples of best practice, including case studies;</p> <p>d. self-assessment tools to assist Local Government;</p> <p>e. ongoing training and skills development for Local Government staff, including online training options;</p> <p>f. funding for the delivery of the child safeguarding function within smaller, less well resourced (Band 3 and Band 4) Local Governments; and</p> <p>g. expert officers within each region to provide support and guidance to Local Government on child safeguarding.</p> <p>3. The Local Government sector supports Local Government participation in the State's National Redress Scheme, with full financial coverage by the State.</p> <p>COMPLETE</p>		
Central C	25 November 2022 Zone Agenda Item 10.1 Aged Care Services	That the Zone request WALGA to research the impact of this issue on local communities in WA and look to engage the Commonwealth and State Minister of Health and Health Departments to consider solutions.	<p>WALGA has followed up with ALGA to determine if there is a state-wide Local Government response to the 24/7 initiative in the regions. LGNSW have undertaken advocacy in the space around workforce issues and funding for Council run aged care services in regional areas.</p> <p>Research has been undertaken which indicates that residential aged care facilities with 30 or less approved beds in Modified Monash Model 5-7 locations will be eligible for a one-off 12 month exemption from the 24/7 RN responsibility.</p>	April 2023	Nicole Matthews Executive Manager Policy nmatthews@walga.asn.au 9213 2039



			<p>Additionally, residential aged care facilities with, on average, 60 residents or less per day will be eligible for a funding supplement to employ extra RNs to deliver 24/7 RN care.</p> <p>The Federal Government has advised that they are undertaking work to further develop and refine the 24/7 RN responsibility, including modelling aged care RN workforce shortages by region to better inform future exemption arrangements.</p> <p>Ongoing</p>		
Central C	<p>2020 February 21 Zone Agenda Item 12.1 General Practitioner Services in Rural Areas - Shire of Corrigin</p>	<p>That WALGA be requested to investigate tendering issues around General Practitioner Services in Rural Areas with consideration given to including an exemption from tendering for such services under the Local Government (Functions and General) Regulations 1996.</p>	<p>The Minister for Local Government has held 2 roundtable meetings with some of the effected Local Governments and has listened to the argument. The Minister has advised of the following position he will look to implement.</p> <p><i>“Recognising the importance of obtaining value for money in a competitive way in the initial procurement of medical services, an exemption is proposed from the requirement to seek public tenders where a local government is extending, varying or renewing a contract. This will make it easier for local governments to vary and extend contracts relating to the provision of medical services; however, they will still need to go through a public tender process when first engaging a GP.</i></p> <p><i>This will require a council report to be prepared and presented, setting out the basis for making the decision. This is consistent with other decision-making and reporting processes currently undertaken by local governments.”</i></p> <p>Between 35 and 40 Local Governments in regional Western Australia currently subsidise a local GP service in their community. This is an advocacy success for the Local Government sector.</p> <p>The Minister for Local Government has had draft regulations prepared and they should be introduced in the coming weeks.</p>	April 2023	<p>Tony Brown Executive Director, Member Services 9213 2051 tbrown@walga.asn.au</p>



<p>Central C</p>	<p>2021 19 November Zone Agenda Item 12.1 Sector ICT solution</p>	<p>That the Zone request WALGA to research providers and the viability of an in-house IT system.</p>	<p>The idea of an all-of-sector model ICT solution is not viable for the following reasons:</p> <ul style="list-style-type: none"> • Different size Local Governments – no one size fits all; • Local Government’s being at different levels of need and maturity in the ICT requirements; • We are unlikely to get the requisite LG buy-in to warrant the investment; and • The inherent complexity of a custom-built system is time and cost-prohibitive. <p>A more workable suggestion is for a group of similar size/maturity level Local Governments to engage a consultant to define a model set that meets their needs. Any recommendations could be reviewed by a representative of the LG ICT Managers Network to ensure it is appropriate.</p> <p>It would be expected that the following range of recommendations are achievable:</p> <ul style="list-style-type: none"> • Suitable hardware requirements (including remote options where appropriate) • Suggested lightweight accounting software • Baseline model directory structure • Security options • Backup software and procedures • Suitable internet options <p>WALGA is looking to assist in facilitating discussions on a shared service model to research this with a group of Local Governments further. Due to work priorities this work was not carried out in 2022, however work is scheduled this year.</p>	<p>April 2023</p>	<p>Tony Brown Executive Director, Member Services 9213 2051 tbrown@walga.aunz.gov.au</p>
-------------------------	--	--	---	--------------------------	---

Zone Comment

This is an opportunity for Member Councils to consider the response from WALGA in respect to the matters that were submitted at the previous Zone Meeting.

RECOMMENDATION

Moved: President Cr Katrina Crute
seconded: Cr Neil Walker

That the Central Country Zone WALGA Status Report for April 2023 be noted.

CARRIED

11.4 Review of WALGA State Council Agenda – 3 May 2023

Background

WALGA State Council meets five times each year and as part of the consultation process with Member Councils circulates the State Council Agenda for input through the Zone structure.

The full State Council Agenda can be found [here](#).

The Zone is able to provide comment or submit an alternative recommendation that is then presented to the State Council for consideration.

Matters for Decision

7.1 Best Practice Governance Review – Feedback on Governance Model

Executive Summary

- State Council commissioned the Best Practice Governance Review with the appointment of a Steering Committee in March 2022.
- The Steering Committee, which met nine times over the course of the project to date and reported back to State Council several times, finalised its [Final Report](#) in February 2023.
- On the basis of member feedback, the Steering Committee recommended Model 1 as the alternate governance model, which would result in the retention of State Council and Zones and the creation of a Board, with the majority of members elected from and by State Council.
- At their March 2023 meeting, State Council resolved to seek feedback from Members on the proposed model.
- To facilitate feedback from Members, the Final Report was distributed and a webinar was held, which was attended by 48 Local Government leaders;
- Feedback was received from 17 Member Local Governments, with nine Member Local Governments expressing support for the proposed Model 1, and eight Member Local Government outlining concerns with the proposed Model 1 or expressing support for the Current Governance Model.
- Concerns with the proposed Model 1 mostly related to concerns around representation at Board level, including the potential for representational imbalances, and the appointment of independent members, including a suggestion that independent members would be more likely to be metropolitan based.
- Next steps for the project are for two sets of constitutional amendments to be presented to State Council at the July 2023 meeting with the view that these amendments would be presented to Members at the 2023 Annual General Meeting.

WALGA Recommendation

That:

1. This report summarising feedback from Members on the Best Practice Governance Review Final Report be received;
2. Two sets of constitutional changes be developed for consideration by State Council at the July 2023 meeting to be put to the 2023 Annual General Meeting, that:
 - a. Give effect to the revised Model 1, as per the Best Practice Governance Review Final Report; and
 - b. Refine the constitution to address inconsistencies and other issues while maintaining the current governance model.

Alternative Motion

Moved: President Cr Phil Blight

Seconded: President Cr Katrina Crute

That:

1. **This report summarising feedback from Members on the Best Practice Governance Review Final Report be received;**
2. **Any decision by the Members to alter the governance structure of WALGA be put as a stand alone item prior to consideration of constitutional amendments; and**
3. **Two sets of constitutional changes be developed for consideration by State Council at the July 2023 meeting to be put to the 2023 Annual General Meeting, that:**
 - a. **Give effect to the revised Model 1, as per the Best Practice Governance Review Final Report; and**
 - b. **Refine the constitution to address inconsistencies and other issues while maintaining the current governance model.**

CARRIED

7.2 Department of Local Government, Sport and Cultural Industries' Child Safe Awareness Policy Template

Executive Summary

- Since 2020, the State Government has consulted with the Local Government sector in relation to Recommendation 6.12 from the Royal Commission into Institutional Responses to Child Sexual Abuse (Royal Commission), which recommended that Local Governments should designate Child Safety Officers, with support from governments at the National and State level.
- In 2022, the Department of Communities (DoC) facilitated a series of co-design sessions which involved 35 representatives from Local Government, the Commissioner for Children and Young People (CCYP), WALGA, and the Department of Local Government, Sport and Cultural Industries (DLGSC) to develop the Child Safe Awareness Policy Template for Local Government (the Policy) to support implementation of Recommendation 6.12.
- The Policy supports initial action by Local Governments in addressing Recommendation 6.12, and forms part of the broader environment of child safe reforms developed out of the findings of the Royal Commission that will impact Local Government.
- DLGSC is seeking WALGA support for the Policy.
- WALGA considers support for the Policy is appropriate but notes that Local Governments will require ongoing support and resourcing assistance consistent with WALGA's *Advocacy Position 3.10.2 Child Safeguarding*.
- WALGA will continue to advocate to the State Government for the Policy to be considered in the context of a broader implementation plan for all the Royal Commission's recommendations relevant to Local Government.

WALGA Recommendation

That State Council:

- 1. Supports the draft Child Safe Awareness Policy Template being provided to Local Governments to assist with their implementation of Recommendation 6.12 of the Royal Commission (Child Safety Officers in Local Government); and**
- 2. Notes the Department of Local Government, Sport and Cultural Industries' commitment to providing ongoing support and resourcing assistance to Local Governments to assist with implementation of the draft Child Safe Awareness Policy Template and other relevant actions relating to child safeguarding, through the Child Safeguarding Implementation Unit.**

7.3 Abandoned Shopping Trolleys Advocacy Position

Executive Summary

- Abandoned trolleys in the public domain, create safety hazards for pedestrian and vehicular traffic and negatively impact public amenity and the natural environment.
- Some retailers prioritise their civic and social responsibilities, however the cost of physically retrieving illegally dumped trolleys is now substantially more than the cost of replacing trolleys.
- The absence of economic or legally enforceable imperative means retailers are increasingly not responding to this issue within reasonable timeframes, if at all.
- In response to community expectations, Local Governments bear the increasing cost burden to remove, impound and eventually dispose of abandoned trolleys.
- The *Public Spaces (Unattended Property) Act 2021* (NSW), presents an example of how legislation can be used to address issues arising from shopping trolleys.

WALGA Recommendation

That State Council endorse the following position on Abandoned Shopping Trolleys:

The Local Government Sector advocates for State Government to consult with the Sector and prioritise legislative reforms that require retailers to contain shopping trolleys within shopping centre property boundaries, inclusive of enforcement and modified penalty mechanisms that are a realistic economic imperative for retailers to comply with containment requirements.

7.4 Speed Management Reform Advocacy Position

Executive Summary

- WALGA's existing policy on speed management is narrow in scope and is inadequate for advocating the varying needs of the Local Government sector.
- Speed management is an important tool for Local Governments, for managing the safety performance of local roads and to help create healthy, vibrant, and connected communities.
- Changing speed limits is an important element of speed management but the application process can be difficult and Local Governments currently have limited influence in the determination of speed limit changes on local roads.
- A contemporary advocacy position on speed management will enable WALGA to advocate for reforms that are needed to better reflect the diverse needs of Local Governments and enable effective and responsible management of travel speeds on local roads.

WALGA Recommendation

That the Speed Management Advocacy Position as follows, be endorsed:

1. *That WALGA supports Local Governments wishing to manage travel speeds, including speed limit changes, as a means of achieving the many health, social and environmental benefits for communities.*
2. *That Main Roads WA (MRWA) retain the overarching authority for speed limit setting/zoning.*
3. *That Main Roads WA speed zoning policies and processes be reformed so that Local Governments are more influential in the determination of speed limit decreases or increases for local roads.*
 - a. *This will include applications that are deemed to be approved when the application:*
 - i. *is based on assessments by competent Local Government practitioners,*
 - ii. *contains evidence-based identification of the benefits,*
 - iii. *contains preliminary designs for infrastructure safety upgrades associated with applications to increase speed limits, and*
 - iv. *includes an engagement strategy for managing community and stakeholder expectations.*
 - b. *Allows for Main Roads WA to decline an application, within a mutually agreed timeframe, on the basis that it:*
 - i. *does not meet the above criteria, and*
 - ii. *provides specific evidence for declining the application.*
4. *The WALGA seeks to work with Main Roads WA and other stakeholders, to develop a speed management guide for Local Governments.*

7.5 State Road Funds to Local Government Agreement 2023/24 to 2027/28

Executive Summary

- The State Road Funds to Local Government Agreement (Agreement) provides funding for Local Governments to improve and maintain the local road network.
- The new Agreement continues to provide 20% of vehicle license fee revenue collected by the State Government to be applied to Local Government roads and paths.
- The proposed Agreement is for a five-year term from 2023/24 to 2027/28.
- The overall structure and intent of the Agreement remains largely unchanged from the previous Agreement.
- Commitments to road safety, aboriginal employment and recycled materials have been expanded.
- The Agreement was developed through consultation with Local Government members of the State Road Funds to Local Government Advisory Committee (SAC), Main Roads WA and Regional Road Group representatives.

WALGA Recommendation

That the State Roads Funds to Local Government Agreement 2023/24 – 2027/28 be endorsed.

Policy Team Reports

8.1 Environment and Waste Policy Team Report

The Environment and Waste Policy Team includes the following subject areas:

- *Climate change*
- *Native vegetation and biodiversity*
- *Biosecurity*
- *Water resources*
- *Sustainability*
- *Waste management*

WALGA Recommendation

That the matters considered by the Environment and Waste Policy Team be noted.

8.2 Governance and Organisational Services Policy Team Report

The Governance and Organisational Services Policy Team includes the following subject areas:

- *Employee Relations*
- *Governance*
- *Strategy and Association Governance*
- *Training*
- *Regional Capacity Building / Local Government Reform*

WALGA Recommendation

That State Council:

- 1. Retain, without amendment, Advocacy Positions:**
 - (a) 2.1.14 Financial Assistance Grants**
 - (b) 2.4.4 Remote Area Tax**
 - (c) 2.5.21 Conduct of Postal Elections**
 - (d) 2.5.39 Exemption from ASSB124**
- 2. Delete Advocacy Positions:**
 - (a) 2.5.14 Tender Threshold**
 - (b) 2.5.26 Simple and Absolute Majority**
- 3. Notes the GOS Policy Team's consideration of WALGA AGM 2022 Item 3.12.1 Abandoned Shopping Trolleys.**

8.3 Infrastructure Policy Team Report

The Infrastructure Policy Team includes the following subject areas:

- *Roads and paths*
- *Road safety*
- *Transport*
- *Freight*
- *Utilities (including telecommunications and underground power)*

WALGA Recommendation

That the matters considered by the Infrastructure Policy Team be noted.

8.4 People and Place Policy Team Report

The People and Place Policy Team includes the following subject areas:

- *Community*
- *Emergency Management*
- *Planning and Building*

WALGA Recommendation

That the matters considered by the People and Place Policy Team be noted.

Matters for Noting/Information

- 9.1 2023 Policy Priorities
- 9.2 Local Emergency Management Arrangements (LEMA) Review Project
- 9.3 Submission to the Independent Review of WA's COVID-19 Management and Response
- 9.4 Submission to the DWER E-waste to Landfill Ban Consultation Paper
- 9.5 Report Municipal Waste Advisory Council (MWAC)
- 9.6 March 2023 Economic Briefing

RECOMMENDATION

Moved: President Cr Phil Blight
seconded: Cr Graham Broad

That the Central Country Zone:

- 1. Supports all Matters for Decision except item 7.1 as listed above in the May 2023 State Council Agenda; and**
- 2. Notes all Matters for Noting and Organisational Reports as listed in the May 2023 State Council Agenda.**

CARRIED

11.5 WALGA President's Report

The WALGA President's Report was attached to the Agenda.

Noted

12. Emerging Issues

12.1 Executive Committee member appointment

Cr Len Armstrong has recently resigned from the Central Country Zone Executive Committee, leaving a vacant position to be filled. We are looking for a nomination for a further Executive Committee member.

Cr Karen Harrington, Shire of West Arthur nominated for the position. There being no further nominations, Cr Harrington was appointed to this position.

RESOLVED

12.2 *Aboriginal Cultural Heritage Act* breaches

Cr Ross Chappel, Shire of Lake Grace

A man has recently been charged in York for breaching the *Aboriginal Cultural Heritage Act 1972* (ACH Act). It is important to be aware of responsibilities under the ACH Act, given that ignorance will no longer be a defence under the new Act.

Noted

12.3 Live Sheep Exports

President Cr Phil Blight

Moved: President Cr Phil Blight

Seconded: Cr Karen Harrington

That the Zone write to the Premier and request his strong public advocacy to retain live sheep exports.

CARRIED

13. Date, Time, and Place of Next Meeting

The next Central Country Zone meeting will be held on Friday, 23 June 2023 commencing at 9:30am. This meeting will be hosted by the Shire of Dumbleyung.

14. Closure

There being no further business the Chair declared the meeting closed at **12:26pm**.

CBH Group

Strategy and Network Investment Plan

Now to 2033

WALGA Central Country Zone
April 2023



CBH exists to sustainably create and return value

Grower Value Chain



CBH contribution to WA



1,100_{FTE}

+~2,000 *harvest
casuals*



\$4bn

Capital expenditure & maintenance
plan in the next 10 years



~**\$8bn**

Annual export value

Future challenges and opportunities

Growing received crop size

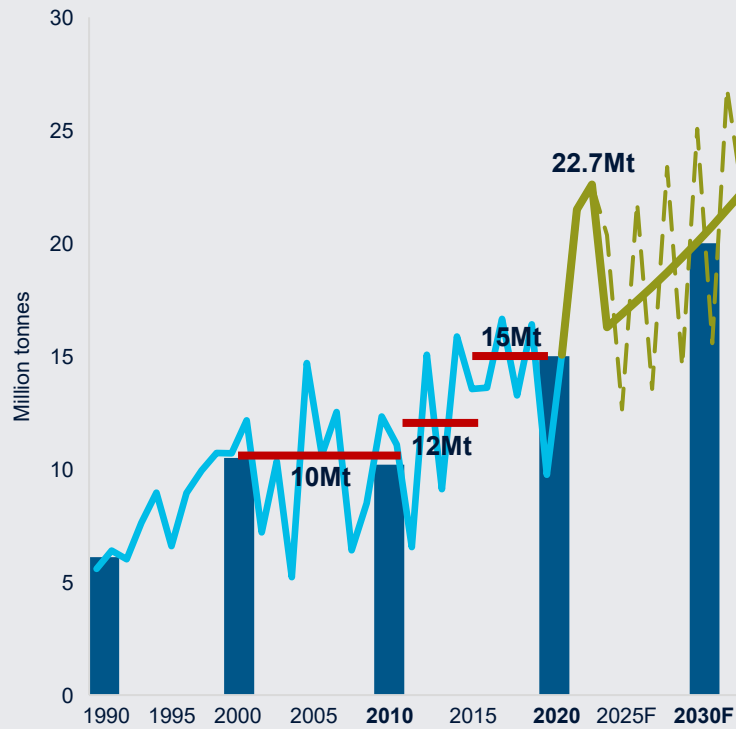

First half tonnes to port



First half price premium

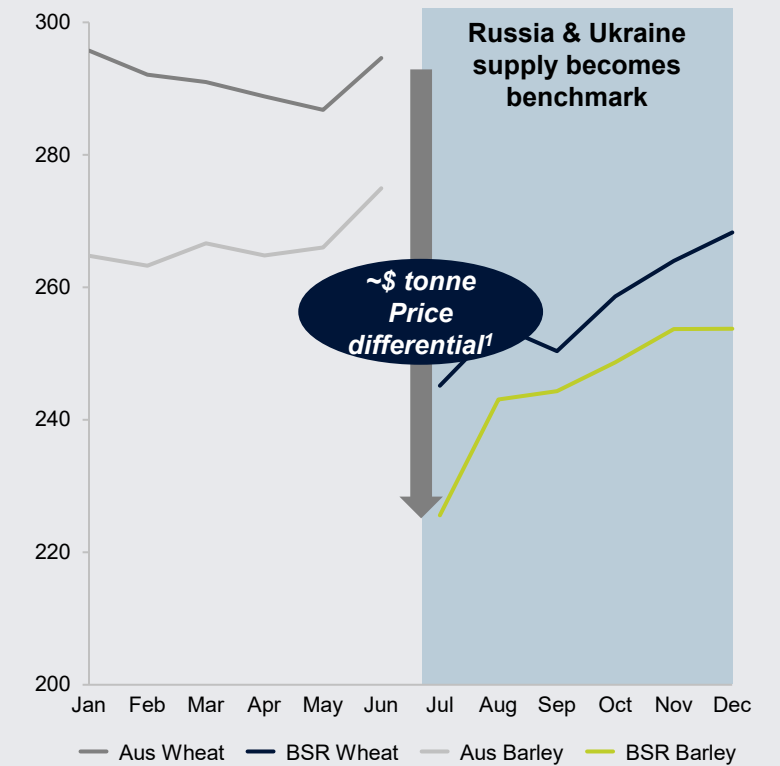

Path to 2033

CBH Strategic Objectives

- 1** Receive an average **22Mt** crop and **out-turn 70%** in the first-half shipping window
- 2** **Market ~50%** of the crop to international customers
- 3** Hold a **15%** market share in the **fertiliser** market

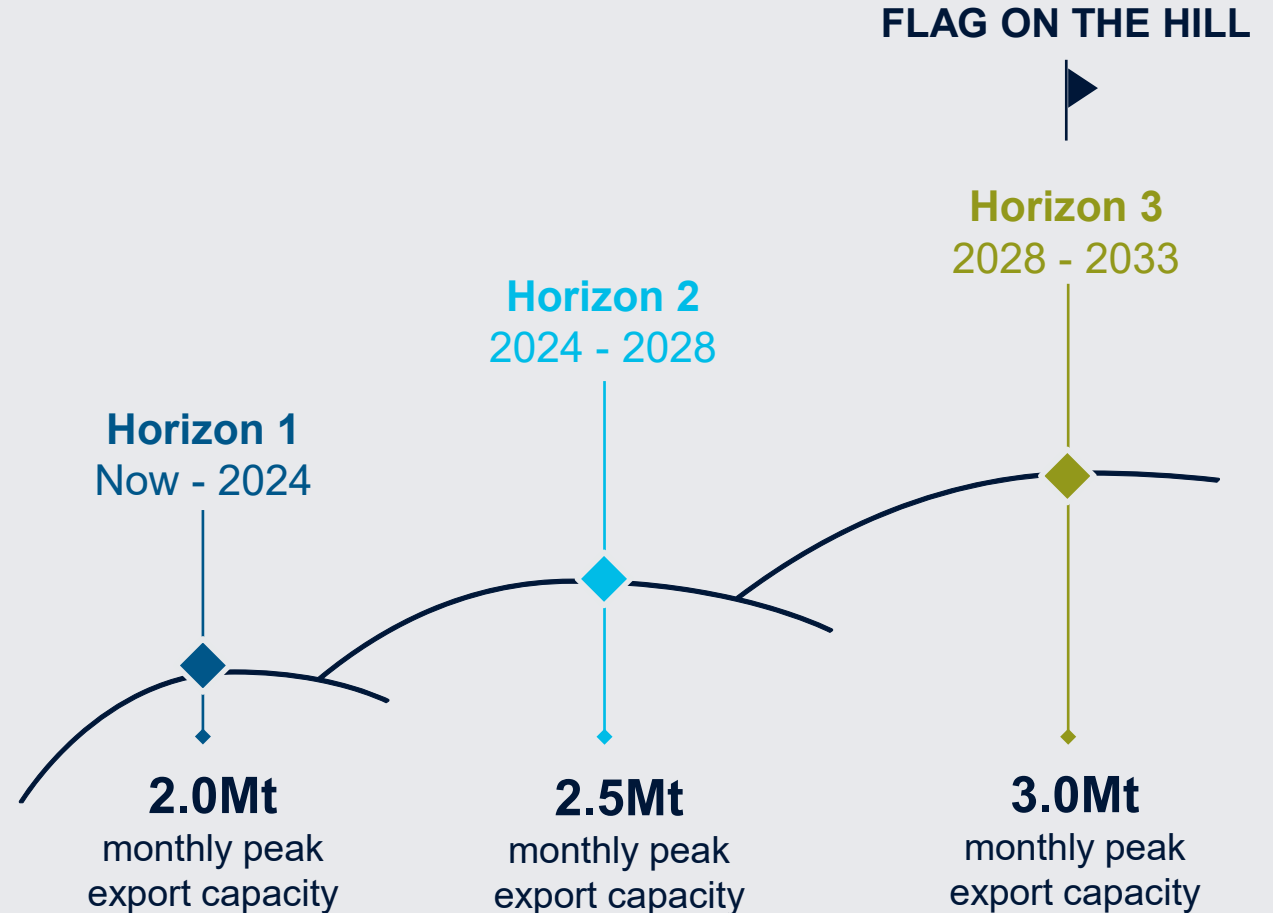

Current and future CBH network investment

Expand and Enhance



Dumbleyung permanent expansion

Out-loading



Brookton rail siding extension

Accommodation



Accommodation example – Gairdner

Current and future CBH out-loading investment

2033 Forecast Annual Network Rail Tonnes

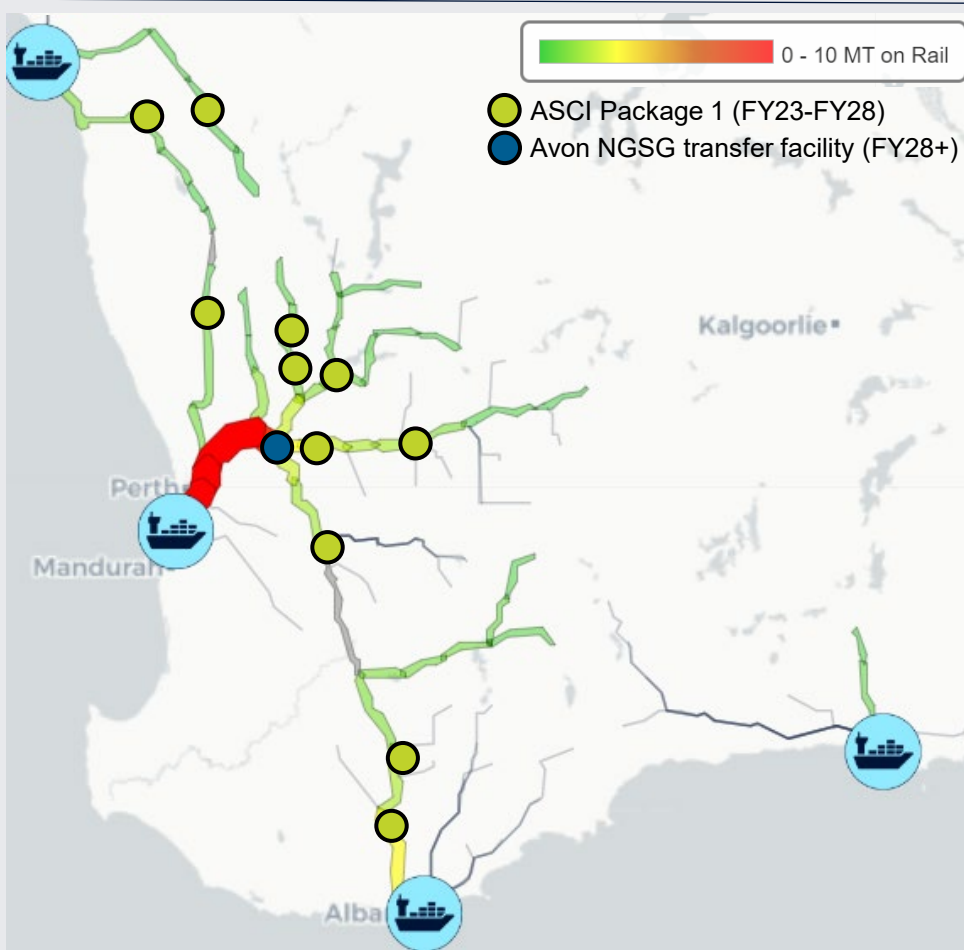

Proposed strategic out-loading investments

ASC I Package 1 – Govt. funding committed*

11 rail facility & siding projects

- Moora
- Brookton
- Broomehill
- Cranbrook
- Konnongorring
- Meenaar
- Dowerin
- Mingenew
- Kellerberrin
- Ballidu
- Perenjori

Rail procurement

- SG and NG locos
- SG and NG wagons

Port investment

- Master planning and Sustaining capital execution across all 4 ports

Community Investment Strategy





WALGA Central Country Zone - PTF presentation



EDM#63391654

Contents

1. Introductions
2. What is PTF
3. PTF Influencing factors
4. PTF Performance History
5. PTF Strategy
6. Plan
7. Questions



What is a Pole Top Fire (PTF)?

Overview - PTFs are caused by leakage current passing through and/or over insulators to the wood pole structure (Crossarm and Wood Poles)

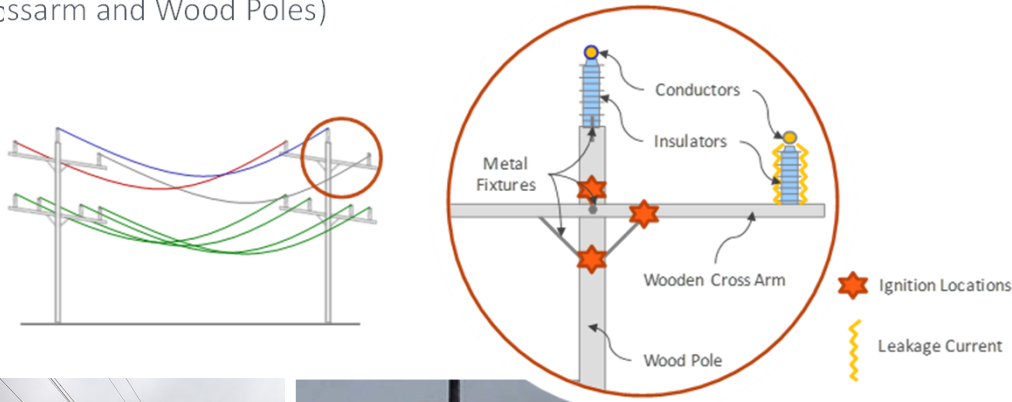

Light rain after dry spell



Metro



NC



MU-KOJ 81



PTF Influencing factors

Western Power's network has approximately >65,000 km of distribution (Dx) overhead (OH) network with >600,000 Dx wood poles including 87% of high voltage (HV) network presenting intrinsic PTF risk.

The factors that predominantly influence the likelihood of PTFs include:

- Pollution source – proximity to coast, industrial pollution, agricultural pollution
- Feeder voltage – 22 kV, 33 kV
- Insulator type – Glass, Porcelain, Cycloaliphatic and Ethyl Vinyl Acetate (EVA)
- Age group – >20 years
- Status & age of silicone application on insulator surface – Silicone treated / not treated, <5 years / 5-8 years / >8 years



PTF Performance History

Western Power have predominately installed Porcelain and Glass historically. Western Power currently installs EVA (introduced circa 2000s) and silicone rubber insulators (introduced circa 2018).

Table below provides a summary PTF performance over a 3 year period:

HV Insulator Type	PTF Rate (normalised)	19/20	20/21	21/22	Total
Porcelain/Glass - Silicone age <8 years	0.01%	29	12	20	61
Porcelain/Glass -silicone age >8 years or not treated with silicone	0.08%	307	180	208	695
EVA	0.04%	57	21	58	136
Cycloaliphatic	0.02%	77	29	48	154
Other	NA	19	4	40	63
Grand Total	NA	489	246	374	1,109

PTF Strategy

Silicone treatment strategy

- Proactively apply silicone treatment on all glass, porcelain and cycloaliphatic insulators prioritised by risk.
- After a 3 year pause of live line ground based silicone application due to a safety incident, WP has recently successfully trialled live line washing and siliconging utilising helicopters and intends to silicon around 10,000 structures per annum through this solution once fully implemented.

Replacement strategy

- Proactively replace targeted insulators at risk of PTFs where silicone treatment cannot be applied.
- Proactively replace targeted insulators that have reached end of life and replace insulators as part of replacing a pole or crossarm.



PTF Strategy

Customer engagement strategy

- Provide locally focussed communication to the customers to manage expectations by communicating potential PTFs and possible long response times, to enable customers to prepare themselves appropriately.

Alternative mitigation trials

Investigate alternative PTF technology mitigation solutions to augment existing toolkit. Examples of trials indented to commence within a year include :

- Trial of a solution to bond the HV insulators to the running earthwire.
- Trial of Live-line silicone treatment of insulators without washing.
- Trial of early fault detection devices to detect early signs of leakage currents.

Note that these solutions will only be implemented by WP if they are proven acceptable at the conclusion of the trial.

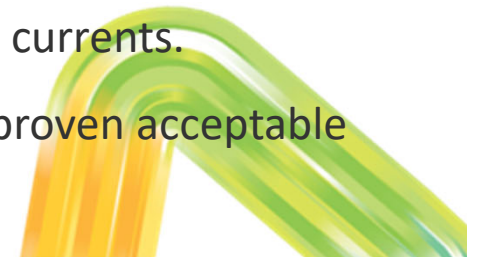

Questions

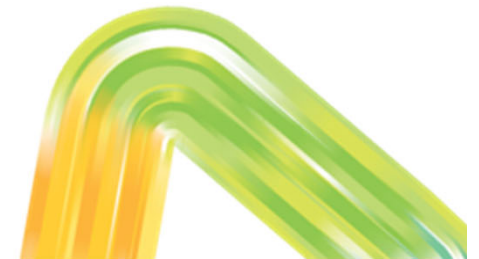

Asset Performance



Head office

363 Wellington Street
Perth, WA 6000

westernpower.com.au



Lake Grace Roadwise

M: PO Box 177 Lake Grace WA 6353

P: 08 9865 1470

E: central@lakegracecrc.net



Minutes of Lake Grace RoadWise Committee Meeting.

10:30am, Thursday 11th May 2023 at the Lake Grace CRC

Present: Joshua Egan-Reid (Police), Lois Dickins (Ambulance), Craig Elefson (Shire), Cathy Morey (MRD), Rodney Thornton (RSO), Jason Lip (Shire), Suzanne Reeves (CRC).

Apologies: Debbie Clarke.

Confirmation of previous minutes: 2nd March 2023

Business Arising from Previous Minutes:

- **Speed signage for Griffin Street** – speed zone isn't clear. Needs a 50 or 60 km/hr sign closer to the highway
- **Street lighting** – not much chance of anything happening with this as Western Power have raised the cost of street lighting for Local Governments by 40%
- **SAMM Trailer** – is in the Shire depot. Can it be put out for football, put Belt Up on it. Needs to be out more.
- **Crossroads (Lake Grace & Lake King)**. Main Roads, police and Shire had a good meeting regarding the site; positive ideas have come out of that. Work has started on them. Lake Grace crossroads will be getting
 - Increase the size of the Stop sign – currently size B 750 mm x 750 mm to Size C 900 mm x 900 mm
 - Installation of reduce speed sign – size 1250 mm x 1900 mm with cross intersection symbol in the diamond.
 - Installation of rumble strips on North leg of the intersection and investigate suitable location for rumble strips on South leg of the intersection (Residential property on street)
 - Installation of Raised Pavement Marker (RPM) on the centreline
 - On the 16th and 17th May the road will be closed between intersection and Dewar Street as there will be resurfacing done around the rail line. Will have to detour.
- **Understanding Grief & Loss workshop (What to do after an accident)**. Is set for June 14th, we are getting this as a freebie as CBH had sponsored Injury Matters to do some training in the wheatbelt.
- **First Aid course for P Platers**. This will be happening on Friday 6th October, when St John heard what we were doing they dropped the price. Just need to get some funding.
- **Rifle Range Hill / Beenong Rd Shoves** – are in the system being prioritised (shortage of funding)
- **Biddy Camm – Lake Grace Gorge Rock Road** – carry over to next meeting
- **Towing Ag Equipment Information session** – went well, had 35 in attendance.
- **Wombat signs** – they were actually up before humps went down. 0% for observance 😊
- Rodney has received the **smashed up car** as requested, hoping to have it on display for the football this weekend (and the following one).
- Rodney did a '**Snap Send Solve**' for the pothole/shove on Tarin Rock – Harrismith road.
- **Amount of land that will go under water due to the causeway being raised** – Cathy has been unable to get any answers to survey regarding this. Shall continue to follow up.

RSO Report:

- Traditional road safety was about driver behaviour (seat belts, drunk/drug driving, speed, distraction). The new methodology from the Office of Road Safety is that accidents can happen, no one plans them and that there is a suite of factors that contribute to the

Lake Grace Roadwise

M: PO Box 177 Lake Grace WA 6353

P: 08 9865 1470

E: central@lakegracecrc.net



outcome of an accident such as road safety treatments (ie audible barriers) and safe vehicles. Audible barriers are expensive but going forward it would be wise to include this in the cost of the road ie. Instead of resurfacing 20km of road, resurface 18km and include audible barriers.

Correspondence Out:

- Minister Papalia – letter re intersection. Sent one day before accident.

Correspondence In:

- Fitzpatrick – copy of grievance that Peter Rundle put before parliament re the crossroads.
- Saffiotti – reply to previous letter.

Financial Report:

\$210.95 in cheque account, \$1,665.33 in savings account. \$400 spent on catering and venue hire for Towing Ag Equipment information session. Earned 2 cents interest.

General Business:

- **Driver Reviver (Easter report).** We didn't have open for the Monday as not enough volunteers. Open for 12 hours over two days with 54 using the service. Nine volunteers completed 18 hours.
- **Kids on bikes.** There's a lot of kids on bikes in the 5-10 year age group; not being completely silly but not the best with their road rules. Josh will talk to the school about running some bike safety education with the students. They all appear to be wearing helmets which is a big tick.
- **Verge drop offs** on old bitumen on North road – Cathy will add to the list.
- **Entry speed signage** will be changing at town boundaries so that there will only be two signs. This will be happening everywhere.
- **Intersection accident** has been a catalyst for improvements to the crossroads. When it happened only one ambulance officer in town (others were working at Wagin Woolorama – as were police). St John Comms struggled to understand distance between Wagin and Lake Grace. Further ambulance volunteers arrived in 15-20 minutes from farmlands. The initial officer coped very well with the situation (multiple patients). Occupants of vehicles had a relatively positive outcome due to seatbelt usage and for the east bound car having a 5-star ANCAP rating.
- **Smiley face LED speed signs** Shire would like to install two of these at east and west entries. Some confusion with MRD permissions but won't be a problem, Cathy to follow up.

Meeting closed: 12:15pm

Next meeting: 24th August 2023. 12:30pm.